

MV3.0



**Valvole e accessori  
idraulici**

**Valves and hydraulic  
accessories**

Catalogo generale / General catalogue





# Indice

## Index

---

<b>Qualità e innovazione</b> Quality and innovation . . . . .	5	<b>Valvole di ritegno</b> Check valves . . . . .	11
<b>Missione, visione e valori</b> Mission, vision and values . . . . .	7	<b>Valvole di intercettazione</b> Shut-off valves . . . . .	49
<b>Produzione</b> Production . . . . .	8	<b>Valvole motorizzate</b> Actuated valves . . . . .	101
		<b>Filtri</b> Filters . . . . .	111
		<b>Collettori e flange</b> Manifolds and flanges. . . . .	121
		<b>Serbatoi</b> Pressurized tanks. . . . .	147
		<b>Accessori per idraulica</b> Hydraulic equipment. . . . .	153
		<b>Raccorderia</b> Pipe fittings . . . . .	171

**Mondeo persegue costantemente una politica di continua ricerca e sviluppo. Pertanto si riserva il diritto di modificare le caratteristiche tecniche, estetiche e i prezzi dei suoi prodotti in qualsiasi momento e senza alcun preavviso.**

Mondeo constantly pursues opportunities for research and growth. Consequently, it reserves the right to adjust the technical and outward features, as well as the prices, of its products at any time and without prior notice.





## Qualità e innovazione

## Quality and innovation

- **L'innovazione rappresenta la nostra identità aziendale, l'intuizione il filo conduttore della nostra storia.** / Innovation is our company identity, intuition guides our history.
- **La storia di Mondeo comincia nel 1986, quando il fondatore Giancarlo Ghiotto decide di dedicarsi alla produzione di valvole idrauliche. Dopo aver creato prima un'azienda di motori elettrici per le pompe monofase e successivamente un'azienda di elettropompe, sceglie di applicare la sua esperienza nella movimentazione dei fluidi proprio a quel componente che ne regola il flusso e che riveste pertanto un ruolo fondamentale nel garantire specifici valori di pressione e portata. Sono lo spirito imprenditoriale, ma soprattutto la grande curiosità e il forte amore per la ricerca, a spingerlo verso questa nuova avventura.**

**Usando una formula che già aveva avuto successo nelle pompe idrauliche, Mondeo si presenta sul mercato con un prodotto totalmente innovativo: una valvola in acciaio inox stampato. Si trattava di un'autentica novità per il settore e di una filosofia produttiva completamente diversa. I vantaggi dell'acciaio inox erano evidenti: maggior durata della valvola, minor perdita di carico e quindi minor energia consumata.** / The story of Mondeo began in 1986, when its founder, Giancarlo Ghiotto, decided to specialise in the production of hydraulic valves. After establishing a company that made electric motors for single phase pumps, followed by a motor pump company, he chose to apply his experience to the movement of fluids, more precisely to the component that regulates the flow and which therefore plays a fundamental role in guaranteeing specific pressure and flow rate values.



It was his business spirit, but above all his immense curiosity and strong love for research, that pushed him towards this new adventure. Using a formula that was already successful for hydraulic pumps, Mondeo presented itself to the market with a totally innovative product: a valve made of stamped stainless steel. It was a true sector novelty, and a completely different production philosophy. The advantages of stainless steel are evident: longer-lasting valves, less head loss, so less consumed energy.

- **La sfida era quella di proporre un prodotto di qualità maggiore rispetto all'ottone, ma a un prezzo ragionevole rispetto a quello dell'acciaio da fusione.** / The challenge was to introduce a product made from a higher quality material than brass, but with a more reasonable price than cast steel.
- **Il primo ad accogliere la nuova formula, che coniugava qualità, efficienza e prezzo competitivo, fu il mercato tedesco, particolarmente sensibile all'aspetto della**

**qualità e già fortemente indirizzato all'utilizzo dell'inossidabile nell'idraulica.** / The first to welcome the new formula, which blended quality, efficiency and a competitive price, was the German market, particularly sensitive to quality and already insistently heading towards the use of stainless steel in hydraulics.

- **Dopo questo riconoscimento importante, da parte di un mercato sinonimo di autorevolezza nel settore idraulico, l'azienda non ha mai smesso di crescere investendo in ricerca, nuovi prodotti e commercializzazione a livello mondiale.** / After this important recognition from a market that is famous for its authoritativeness in the hydraulics sector, the company never stopped growing, investing in research, new products and marketing at world level.
- **Oggi Giancarlo Ghiotto, presidente dell'azienda, è affiancato dai figli Nicola, amministratore delegato dal 2016, e dalla figlia Lorenza, responsabile del coordinamento interno dell'azienda. Il carattere familiare è per Mondeo un grande valore aggiunto, che si traduce internamente in un clima di collaborazione e fiducia, e all'esterno in un approccio diretto e personale con i propri clienti.** / Today Giancarlo Ghiotto, chairman of the company, works alongside his sons Nicola, managing director since 2016, and Lorenza, who heads the company's internal coordination. Being a family business gives the company added value according to Mondeo, value that translates internally into a climate of collaboration and trust, and externally into a direct, personal approach to clients.



# Missione, Visione e Valori

## Mission, Vision and Values

---

### La nostra missione / Our mission

- **Vogliamo rappresentare il Punto di Riferimento in Europa nel mercato dei componenti in acciaio inossidabile per la movimentazione dei fluidi. Privilegiamo attività di produzione, coprogettazione e selezione di soluzioni ad alto valore aggiunto, attraverso collaborazioni solide con clienti e fornitori. Operiamo con una squadra di persone competenti e dinamiche, determinate a soddisfare tempestivamente le esigenze specifiche dei nostri interlocutori.**  
/ We want to be a Reference Point in Europe for the stainless steel component market for fluid handling. We privilege production, co-design, and the selection of solutions with high added value through solid collaborations with clients and suppliers. We work with a team of skilled and dynamic people who are determined to satisfy the specific needs of our representatives quickly.

### La nostra visione / Our vision

- **Siamo il Partner Globale e Inossidabile per tracciare nuove rotte nella movimentazione dei fluidi.** / We are a global, stainless partner for tracing new routes in fluid movement.

### I nostri valori / Our values

- **Mettiamo sempre Passione: per ricercare l'eccellenza in tutte le nostre azioni.** / We are always enthusiastic: we find excellence in all our actions.
- **Abbiamo senso di appartenenza: per vincere tutti insieme le sfide quotidiane.** / We feel we have sense of belonging: we face daily challenges together.
- **Siamo ispirati dal cliente: per creare assieme valore e miglioramento continuo.** / We are inspired by our clients: we create value and continual improvement together.
- **Operiamo con impegno e coinvolgimento: per trasformare le attività ordinarie di ognuno in risultati straordinari per tutti.** / We operate with diligence and involvement: we transform the ordinary operations of each one of us into extraordinary results for everyone.



## Produzione

## Production

- **Efficienti nella produzione, efficaci nella qualità.** / Efficient with production, effective with quality
- **Ricerchiamo la qualità non attraverso il controllo del prodotto ma già nel momento della progettazione e del processo produttivo.** / We search for quality, not through product checks but starting from when we design the product and during the production process.
- **Il nostro obiettivo sono standard sempre più alti di efficienza e qualità.** / Our objective is to have continually higher standards of efficiency and quality.
- **Consideriamo il prodotto nel suo insieme per puntare a una costante semplificazione che ci renda sempre più competitivi sui prezzi.** / We consider the product as a whole thing and aim at constant simplification, which makes our prices more competitive.
- **Stimolati anche dai nostri clienti, ricerchiamo nuove soluzioni e la compatibilità dei nostri prodotti con nuovi utilizzi.** / Also stimulated by our clients, we look for new solutions and investigate the compatibility of our products with new uses.

### Taglio laser / Laser cutting



- **Disponiamo di una macchina laser specializzata per il taglio, la foratura e la marchiatura di tubi tondi fino a 120mm di diametro.** / We have a laser machine specifically for cutting, drilling and marking round pipes of diameter up to 120 mm

### Saldatura / Welding



- **Le tecniche di lavorazione che adottiamo ci permettono di realizzare saldature a tenuta a TIG, senza apporto di materiale, sinonimo di qualità e di tenuta ottimale.** / The process techniques we use allow us to produce TIG-welded joints without any additional welding material, a synonym of optimal welding quality.



## Estrusione / Extrusion



- **Applichiamo questa tecnica già collaudata attraverso un impianto realizzato su nostre specifiche indicazioni. L'automatizzazione di questa fase della lavorazione ci consente un'elevata velocità di produzione e di avere un prodotto pronto per la saldatura con tolleranze molto strette. La grande versatilità della macchina ci garantisce velocità di attrezzaggio anche per piccole serie.** / We apply this already-tested process using a system made according to our specific indications. Automating this processing phase gave extremely fast production speeds and a product that is ready to be welded with very narrow tolerances. The great versatility of the machine guarantees fast tooling time also for small batches.

## Lavorazioni meccaniche / Mechanical finishing



- **Tutti i componenti saldati sono realizzati internamente con macchine a controllo numerico. Oltre alle lavorazioni effettuate internamente, ci serviamo di fornitori selezionati che consideriamo partner strategici per operazioni specializzate. Tra queste ci sono la realizzazione di particolari stampati e l'idroformatura, tecnica veloce e precisa, con cui realizziamo i collettori per gli impianti di riscaldamento.** / All the welded components are produced in-house with numeric control machines. In addition to the processes used in the company, we also have selected suppliers who we consider as strategic partners for specialized operations, for example the production of cold pressed parts and hydroforming, a fast, precise process that we use to produce manifolds for heating systems.





## Valvole di ritegno Check valves

- **Le valvole di ritegno, dette anche valvole di non ritorno, consentono il passaggio dei fluidi in una sola direzione. Vengono inserite negli impianti idraulici in posizione di uscita dove sia necessario evitare il ritorno del fluido, sia che si tratti di acqua sanitaria, aria, liquidi industriali, di scarico e di fognatura. Il funzionamento della valvola di ritegno è automatico ed avviene in virtù della differenza di pressione tra la sezione a monte e quella a valle dell'otturatore.** / Check valves, also called non-return valves, allow fluids to flow in a single direction. You can find them at the outlet of the hydraulic system, where fluid return has to be avoided, no matter whether domestic hot water, air, or industrial, discharge and drainage liquids. Check valves work automatically and according to the difference in pressure between the section upstream and downstream of the stem.
- **A seconda del sistema di chiusura si possono distinguere in valvole di ritegno a molla, a disco, a palla, a disco tipo wafer, valvole wafer doppio battente, a clapet e a clapet tipo wafer e valvole di fondo.** / The valves can be spring loaded, disc, ball, wafer disc, double disc wafer, swing, wafer swing and foot flanged according to the closing system.
- **Sono disponibili in acciaio Aisi 304 e Aisi 316, in ottone, ghisa e plastica. In particolare le valvole di ritegno in acciaio inox di produzione Mondeo - Idrja, Small, Glovalve e Floy – grazie alla particolare forma costruttiva garantiscono perdite di carico contenute e il miglior rendimento idraulico dell'impianto.** / They can be made of Aisi 304 and Aisi 316 steel, brass, cast iron and plastic. The stainless steel check valves produced by Mondeo - Idrja, Small, Glovalve and Floy - guarantee contained load loss and better system efficiency thanks to their special shape.
- **Le valvole di ritegno presentano un ampio range di funzionamento: pressioni d'esercizio da 6 bar a 350 bar e temperature da -25 a +250 °C.** / Check valves cover a wide range of applications: working pressures from 6 bar to 350 bar and temperatures from -25 to +250 °C.
- **La loro versatilità le rende adatte a svariate applicazioni. Sono adatte sia ad un uso industriale che residenziale, in impianti per il trattamento delle acque, di liquidi industriali, in gruppi di pompaggio per acque civili e industriali, per aria compressa, per liquidi di scarico e fognatura.** / Their versatility makes them perfect for various applications. They are suitable for both industrial and domestic use, in water and industrial liquid treatment plants, in pump groups for civil and industrial water, for compressed air, liquid waste and sewers.

M1

## SMALL

Valvole di ritegno di piccolo diametro / Small diameter check valves



Modello / Model

SMALL

Materiale / Material

Aisi 304 – 316

Tenuta / Seal

NBR, FPM o PTFE

DN

8 – 15

PN

16

### Caratteristiche tecniche / Construction features

- **Lavorazione: acciaio inox stampato** / Manufacturing process: pressed stainless steel
- **Trattamento superficiale sgrassaggio, decapaggio ed elettrolucidatura** / Surface treatment degreasing, pickling and electropolishing
- **Tenuta** / Seal ring  
NBR, FPM, PTFE
- **Connessioni filettate femmina secondo** / Threaded ends female according to UNI ISO 228/1
- **Saldatura a TIG senza apporto di materiale** / TIG weldings without additional material
- **Pressione di apertura** / Opening pressure  
Min. 0,025 – Max. 0,035 bar
- **Test idraulico di tenuta guarnizioni** / Hydraulic test on the seal rings  
0.2 bar
- **Pressione nominale di esercizio** / Nominal working pressure  
16 bar
- **Temperatura di esercizio** / Working temperature  
-25°C – +90°C NBR  
-20°C – +150°C FPM  
-20°C – +200°C PTFE
- **Certificazioni** / Approvals  
 NSF/ANSI/CAN 61 & 372  
 (solo versioni Aisi 316 FPM / only Aisi 316 FPM types)

### Diagramma pressione temperatura / Pressure temperature diagram

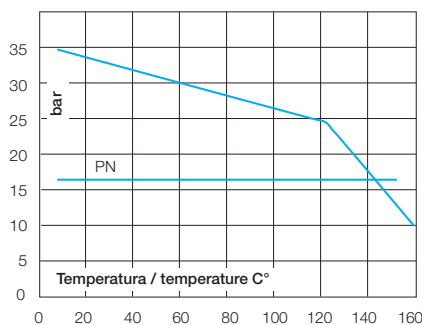

### Perdite di carico / Friction losses diagrams

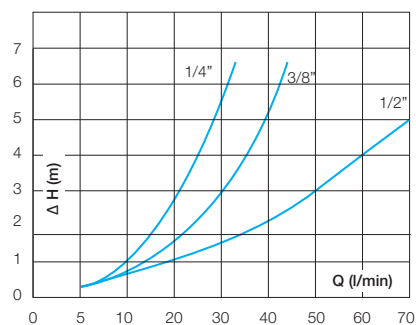

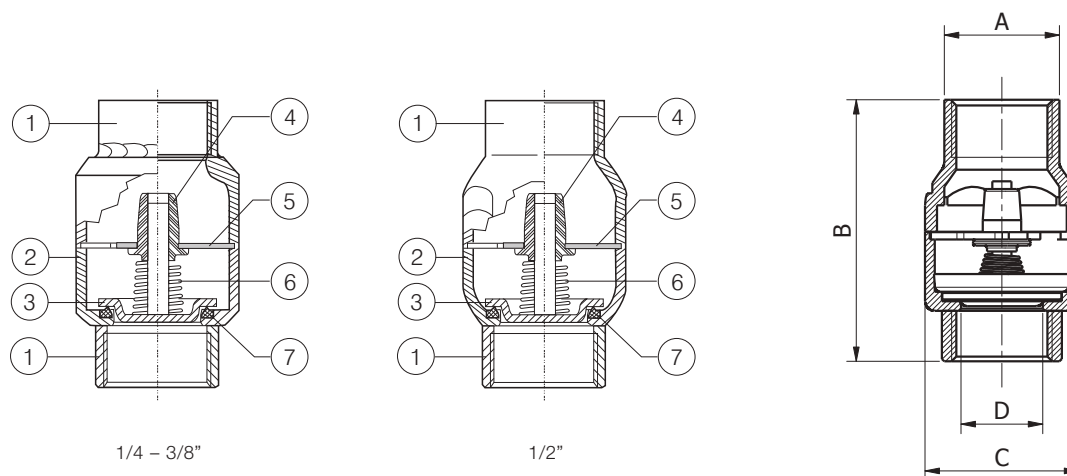

### Componenti e materiali / Components and materials

		Versione Aisi 304 Version Aisi 304	Versione Aisi 316 Version Aisi 316
<b>1</b>	<b>Manicotti filettati /</b> Threaded ends	1.4301 / 1.4304 EN 10088	1.4401 / 1.4404 EN 10088
<b>2</b>	<b>Corpo /</b> Body	1.4301 / 1.4304 EN 10088	1.4401 / 1.4404 EN 10088
<b>3</b>	<b>Otturatore /</b> Flow control disc	1.4301 / 1.4304 EN 10088	1.4401 / 1.4404 EN 10088
<b>4</b>	<b>Boccola di guida /</b> Guide bush	PTFE	PTFE
<b>5</b>	<b>Supporto boccola /</b> Bush support	1.4301 / 1.4304 EN 10088	1.4401 / 1.4404 EN 10088
<b>6</b>	<b>Molla /</b> Spring	1.4301 / 1.4304 EN 10088	1.4401 / 1.4404 EN 10088
<b>7</b>	<b>Guarnizione /</b> Seal ring	NBR, FPM	FPM, PTFE

### Dimensioni e pesi / Dimensions and weights

Codice Code	Misura Size	Materiale Material	Tenuta Seal	DN	PN	Peso in gr. Weight in gr.	KV m <sup>3</sup> /h	Dimensioni in mm Dimensions in mm			
								A	B	C	D
900101	1/4"	Aisi 304	NBR	08	16	105	2,5	20	56	32	1/4" F
900108	3/8"			10	16	90	3,2	20	56	32	3/8" F
900115	1/2"			15	16	90	6,0	25	56	32	1/2" F
900102	1/4"	Aisi 304	FPM	08	16	105	2,5	20	56	32	1/4" F
900109	3/8"			10	16	90	3,2	20	56	32	3/8" F
900116	1/2"			15	16	90	6,0	25	56	32	1/2" F
900104	1/4"	Aisi 316	FPM	08	16	105	2,5	20	56	32	1/4" F
900111	3/8"			10	16	90	3,2	20	56	32	3/8" F
900118	1/2"			15	16	90	6,0	25	56	32	1/2" F
900107	1/4"	Aisi 316	PTFE	08	16	101	2,5	20	56	32	1/4" F
900114	3/8"			10	16	95	3,2	20	56	32	3/8" F
900126	1/2"			15	16	95	6,0	25	56	32	1/2" F

M1

**Modello / Model**  
**SMALL / OR**

**Materiale / Material**  
 Aisi 304 – 316

**Tenuta / Seal**  
 FPM

**DN**  
 8 – 15

**PN**  
 16



### Caratteristiche tecniche / Construction features

- **Adatta ad utilizzo con aria compressa o vuoto in applicazioni non gravose** / For use with compressed air or vacuum in low impact applications
- **Otturatore: acciaio inossidabile Aisi 316 con saldatura rinforzata tra perno e disco** / Flow control disc: stainless steel Aisi 316 with reinforced welding between guiding pin and disc
- **Temperatura di esercizio** / Working temperature  
 -20°C – +150°C

### ■ Certificazioni / Approvals

 NSF/ANSI/CAN 61 & 372  
 (solo versione Aisi 316 /  
 only Aisi 316 type)

### Dimensioni e pesi / Dimensions and weights

Codice Code	Misura Size	Materiale Material	DN	PN	Peso in gr. Weight in gr.	KV m <sup>3</sup> /h	Dimensioni in mm Dimensions in mm			
							A	B	C	D
900102R	1/4"	Aisi 304	08	16	105	2,5	20	56	32	1/4" F
900109R	3/8"		10	16	90	3,2	20	56	32	3/8" F
900124	1/2"		15	16	90	6,0	25	56	32	1/2" F
900104OR	1/4"	Aisi 316	08	16	105	2,5	20	56	32	1/4" F
900111OR	3/8"		10	16	90	3,2	20	56	32	3/8" F
900118R	1/2"		15	16	90	6,0	25	56	32	1/2" F

M1

**Modello / Model**  
**SMALL / DW**

**Materiale / Material**  
Aisi 304 – 316

**Tenuta / Seal**  
EPDM

**DN**  
8 – 15

**PN**  
16



### Caratteristiche tecniche / Construction features

- **Per acqua potabile** / For drinkable water
- **Conforme a** / In conformity with UNI EN 1074-3
- **Temperatura di esercizio** / Working temperature  
-20°C – +110°C

- **Certificazioni** / Approvals



WRAS  
ALS NSF/ANSI/CAN 61 & 372  
(solo versione Aisi 304 /  
only Aisi 304 type)

### Dimensioni e pesi / Dimensions and weights

Codice Code	Misura Size	Materiale Material	DN	PN	Peso in gr. Weight in gr.	KV m <sup>3</sup> /h	Dimensioni in mm Dimensions in mm			
							A	B	C	D
900103A	1/4"	Aisi 304	08	16	105	2,5	20	56	32	1/4" F
900110A	3/8"		10	16	90	3,2	20	56	32	3/8" F
900117A	1/2"		15	16	90	6,0	25	56	32	1/2" F
900106A	1/4"	Aisi 316	08	16	105	2,5	20	56	32	1/4" F
900112A	3/8"		10	16	90	3,2	20	56	32	3/8" F
900120A	1/2"		15	16	90	6,0	25	56	32	1/2" F

M1

**Modello / Model**  
**SMALL / NPT**
**Materiale / Material**  
 Aisi 316

**Tenuta / Seal**  
 FPM

**DN**  
 8 – 15

**PN**  
 16

**Caratteristiche tecniche /**  
 Construction features

- **Adatta ad utilizzo con aria compressa o vuoto in applicazioni non gravose** / For use with compressed air or vacuum in low impact applications
- **Otturatore: acciaio inossidabile Aisi 316 con saldatura rinforzata tra perno e disco** / Flow control disc: stainless steel Aisi 316 with reinforced welding between guiding pin and disc
- **Temperatura di esercizio** / Working temperature  
-20°C – +150°C

- **Filettatura** / Thread  
NPT
- **Certificazioni** / Approvals  
 NSF/ANSI/CAN 61 & 372

**Dimensioni e pesi /**  
 Dimensions and weights

Codice Code	Misura Size	DN	PN	Peso in gr. Weight in gr.	KV m <sup>3</sup> /h	Dimensioni in mm Dimensions in mm			
						A	B	C	D
900104NPTR	1/4"	08	16	140	2,5	20	56	32	1/4" F
900111NPTR	3/8"	10	16	125	3,2	20	56	32	3/8" F
900118NPTR	1/2"	15	16	105	6,0	25	56	32	1/2" F

M1

**Modello / Model**  
**SMALL / TYPE EA**
**Materiale / Material**  
 Aisi 304

**Tenuta / Seal**  
 FPM

**DN**  
 15

**PN**  
 16

**Caratteristiche tecniche /**  
 Construction features

- **Versione antinquinamento controllabile** / Antipollution checkable version
- **Conforme a** / In conformity with  
UNI EN 1717 (tipo / type EA)
- **Foro di ispezione 1/8" gas maschio con tappo su lato aspirazione** / 1/8" male inspection hole with cap on suction side
- **Connessioni filettate femmina secondo** / Threaded ends female according to  
UNI ISO 228/1
- **Temperatura di esercizio** / Working temperature  
-20°C – +150°C

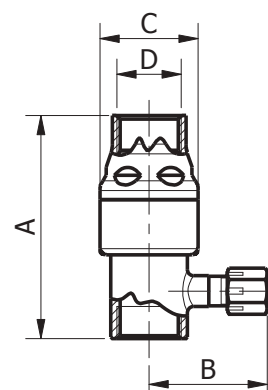
**Dimensioni e pesi /**  
 Dimensions and weights

Codice Code	Misura Size	DN	PN	Peso in gr. Weight in gr.	KV m <sup>3</sup> /h	Dimensioni in mm Dimensions in mm			
						A	B	C	D
900116T	1/2"	15	16	130	6,0	71	40	32	1/2" F



M1

## SMALL / AC

**Valvola di ritegno per utilizzi gravosi e aria compressa di piccolo diametro / Small diameter check valve for heavy duty use and compressed air**

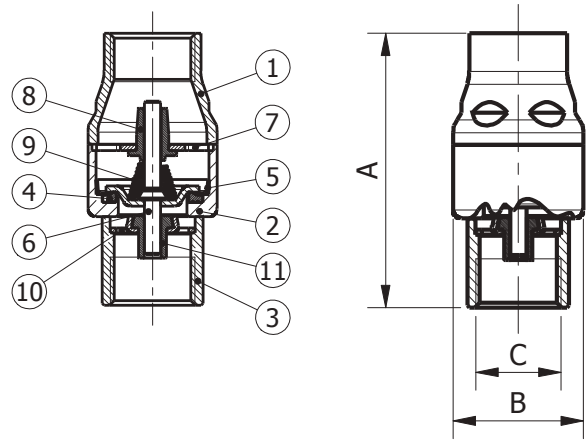

**Modello / Model**  
SMALL / AC

**Materiale / Material**  
Aisi 316

**Tenuta / Seal**  
FPM

**DN**  
15

**PN**  
16

### Caratteristiche tecniche / Construction features

- **Usò con aria compressa /** Compressed air systems
- **Otturatore rinforzato e con doppia guida /** Doubled guided reinforced flow control disc
- **Adatta alle sollecitazioni continue /** Suited for heavy-duty use
- **Trattamento superficiale sgrassaggio, decapaggio ed elettrolucidatura /** Surface treatment degreasing, pickling and electropolishing
- **Connessioni filettate femmina secondo /** Threaded ends female according to UNI ISO 228/1
- **Pressione nominale di esercizio /** Nominal working pressure 16 bar
- **Pressione di apertura /** Opening pressure Min. 0,025 – Max. 0,035 bar
- **Temperatura di esercizio /** Working temperature -20°C – +150°C

### Componenti e materiali / Components and materials

<b>1</b>	<b>Manicotto lato mandata /</b> Outlet end	1.4401 / 1.4404 EN 10088
<b>2</b>	<b>Corpo /</b> Body	1.4401 / 1.4404 EN 10088
<b>3</b>	<b>Manicotto lato aspirazione /</b> Inlet end	1.4401 / 1.4404 EN 10088
<b>4</b>	<b>Anello di tenuta /</b> Seal ring	FPM
<b>5</b>	<b>Anello premi guarnizione /</b> Seal retention ring	1.4401 / 1.4404 EN 10088
<b>6</b>	<b>Otturatore /</b> Flow control disc	1.4401 / 1.4404 EN 10088
<b>7</b>	<b>Supporto boccola superiore /</b> Upper bush support	1.4401 / 1.4404 EN 10088
<b>8</b>	<b>Boccola guida superiore /</b> Upper guide bush	PTFE
<b>9</b>	<b>Molla /</b> Spring	1.4401 / 1.4404 EN 10088
<b>10</b>	<b>Supporto boccola inferiore /</b> Lower bush support	1.4401 / 1.4404 EN 10088
<b>11</b>	<b>Boccola inferiore /</b> Lower bush	PTFE

### Diagramma pressione temperatura / Pressure temperature diagram

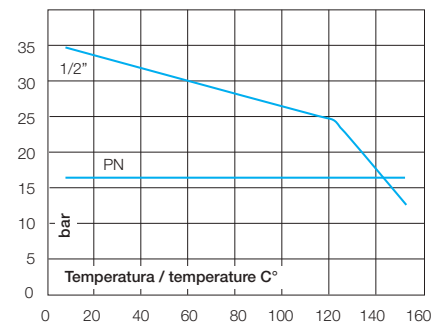

### Perdite di carico / Friction losses diagrams

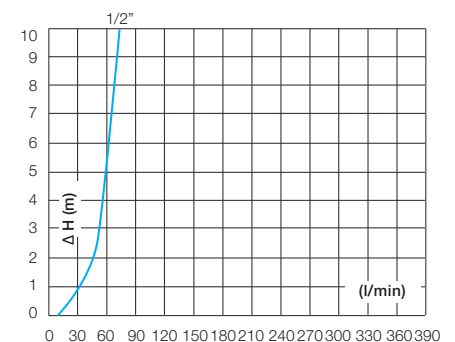

### Dimensioni e pesi / Dimensions and weights

Codice Code	Misura Size	DN	PN	Peso in gr. Weight in gr.	KV m <sup>3</sup> /h	Dimensioni in mm Dimensions in mm		
						A	B	C
900118AC	1/2"	15	16	109	4,1	67,5	32	1/2" F

M1

## IDRJA

**Valvole di ritegno in acciaio inox stampato** / Check valves fabricated from pressed stainless steel



Modello / Model

IDRJA

Materiale / Material

Aisi 304 – 316

Tenuta / Seal

NBR, FPM, PTFE, FEP

DN

20 – 100

PN

16

### Caratteristiche tecniche / Construction features

- **Lavorazione: acciaio inox stampato** / Manufacturing process: pressed stainless steel
- **Trattamento superficiale sgrassaggio, decapaggio ed elettrolucidatura** / Surface treatment degreasing, pickling and electropolishing
- **Tenuta** / Seal ring  
NBR, FPM, PTFE o/or FEP
- **Connessioni filettate femmina secondo** / Threaded ends female according to UNI ISO 228/1
- **Saldatura a TIG senza apporto di materiale** / TIG weldings without additional material
- **Pressione di apertura** / Opening pressure  
Min. 0,025 – Max. 0,035 bar
- **Test idraulico di tenuta guarnizioni** / Hydraulic test on the seal rings  
0.2 bar
- **Pressione nominale di esercizio** / Nominal working pressure  
16 bar
- **Temperatura di esercizio** / Working temperature  
-25°C – +90°C NBR  
-20°C – +150°C FPM  
-20°C – +200°C PTFE o/or FEP
- **Certificazioni** / Approvals  
 NSF/ANSI/CAN 61 & 372  
(solo versioni Aisi 316 FPM / only Aisi 316 FPM types)

### Diagramma pressione temperatura / Pressure temperature diagram

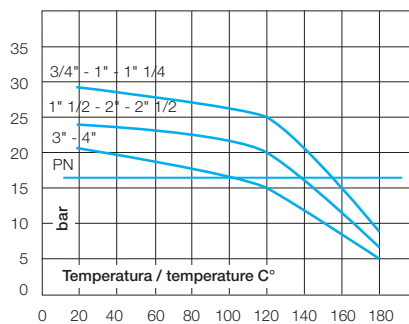

### Perdite di carico / Friction losses diagrams

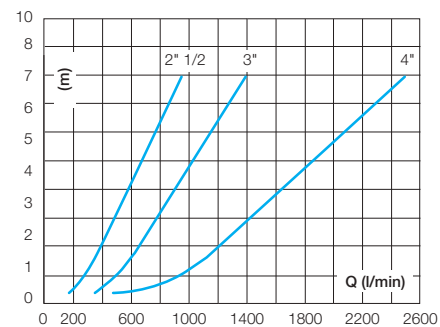
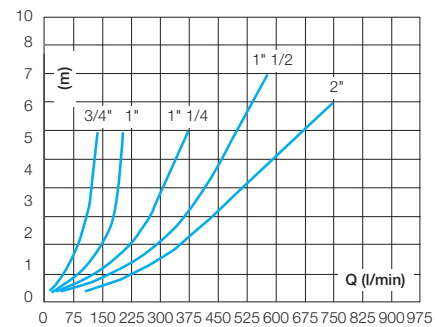

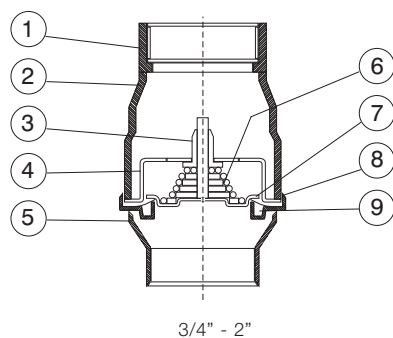

3/4" - 2"

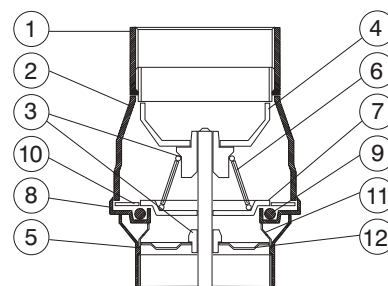

2" 1/2 - 4"

### Componenti e materiali / Components and materials

	Versione Aisi 304 Version Aisi 304	Versione Aisi 316 Version Aisi 316
1 <b>Manicotto lato mandata</b> / Outlet end	1.4301 / 1.4304 EN 10088	1.4401 / 1.4404 EN 10088
2 <b>Corpo</b> / Valve	1.4301 / 1.4304 EN 10088	1.4401 / 1.4404 EN 10088
3 <b>Boccola di guida</b> / Guide bush	PTFE	PTFE
4* <b>Guida otturatore</b> / Flow control disc guide	1.4301 / 1.4304 EN 10088	1.4401 / 1.4404 EN 10088
5 <b>Manicotto lato aspirazione</b> / Inlet end	1.4301 / 1.4304 EN 10088	1.4401 / 1.4404 EN 10088
6* <b>Molla</b> / Spring	1.4301 / 1.4304 EN 10088	1.4401 / 1.4404 EN 10088
7* <b>Otturatore</b> / Flow control disc	1.4301 / 1.4304 EN 10088	1.4401 / 1.4404 EN 10088
8 <b>Contenitore anello di tenuta</b> / Seal ring housing	1.4301 / 1.4304 EN 10088	1.4401 / 1.4404 EN 10088
9* <b>Anello di tenuta</b> / Seal ring	NBR, FPM	FPM, PTFE, FEP
10 <b>Anello ferma tenuta</b> / Seal ring retainer	1.4301 / 1.4304 EN 10088	1.4401 / 1.4404 EN 10088
11 <b>Supporto contenitore tenuta</b> / Seal ring support	1.4301 / 1.4304 EN 10088	1.4401 / 1.4404 EN 10088
12 <b>Guida lato aspirazione</b> / Inlet side guide	1.4301 / 1.4304 EN 10088	1.4401 / 1.4404 EN 10088

\* **Ricambi disponibili solo per versioni** / Spare parts only for versions: 2" 1/2 - 3" - 4"

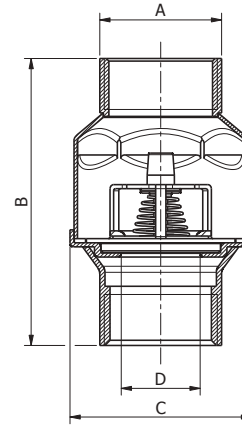

### Dimensioni e pesi / Dimensions and weights

Codice Code	Misura Size	Materiale Material	Tenuta Seal	DN	PN	Peso in gr. Weight in gr.	KV m <sup>3</sup> /h	Dimensioni in mm Dimensions in mm					
								A	B	C	D		
900011	3/4"	Aisi 304	NBR	20	16	129	10,8	30	67	44	18,3		
900016	1"			25	16	191	18,7	35,8	83	53	23,4		
900021	1" 1/4			32	16	281	31,5	45	97	66	31,4		
900026	1" 1/2			40	16	388	40,5	50,8	115	78	36,8		
900029	2"			50	16	704	56	63	120,5	90	42,9		
900055	2" 1/2			65	16	1.425	69	80	142	113	58,7		
900012	3/4"	Aisi 304	FPM	20	16	129	10,8	30	67	44	18,3		
900017	1"			25	16	191	18,7	35,8	83	53	23,4		
900022	1" 1/4			32	16	281	31,5	45	97	66	31,4		
900027	1" 1/2			40	16	388	40,5	50,8	115	78	36,8		
900030	2"			50	16	704	56	63	120,5	90	42,9		
900057	2" 1/2			65	16	1.425	69	80	142	113	58,7		
900402	3/4"	Aisi 316	FPM	20	16	129	10,8	30	67	44	18,3		
900412	1"			25	16	191	18,7	35,8	83	53	23,4		
900422	1" 1/4			32	16	281	31,5	45	97	66	31,4		
900432	1" 1/2			40	16	388	40,5	50,8	115	78	36,8		
900442	2"			50	16	704	56	63	120,5	90	42,9		
900452	2" 1/2			65	16	1.425	69	80	142	113	58,7		
900462	3"	Aisi 316	PTFE	80	16	2.085	99	93	160	132	70,3		
900472	4"			100	16	3.415	181	120	191	167	93,4		
900403	3/4"			Aisi 316	FEP	20	16	129	10,8	30	74	44	18,3
900415	1"					25	16	250	18,7	35,8	90	53	23,4
900424	1" 1/4					32	16	365	31,5	45	101	66	31,4
900433	1" 1/2					40	16	525	40,5	50,8	120	78	36,8
900443	2"	Aisi 316	FEP	50	16	704	56	63	120,5	90	42,9		
900455	2" 1/2			65	16	1.425	69	80	142	113	58,7		
900465	3"			80	16	2.085	99	93	160	132	70,3		
900475	4"			100	16	3.415	181	120	191	167	93,4		

M1

**Modello / Model**  
**IDRJA / OR**
**Materiale / Material**  
 Aisi 304 – 316

**Tenuta / Seal**  
 FPM

**DN**  
 20 – 32

**PN**  
 16

**Caratteristiche tecniche /**  
 Construction features

- **Adatta ad utilizzo con aria compressa o vuoto in applicazioni non gravose** / For use with compressed air or vacuum in low impact applications
- **Otturatore: acciaio inossidabile Aisi 316 con saldatura rinforzata tra perno e disco** / Flow control disc: stainless steel Aisi 316 with reinforced welding between guiding pin and disc
- **Conessioni filettate femmina secondo** / Threaded ends female according to UNI ISO 228/1
- **Temperatura di esercizio** / Working temperature  
-20°C – +150°C
- **Certificazioni** / Approvals  
 NSF/ANSI/CAN 61 & 372  
 (solo versione Aisi 316 FPM / only Aisi 316 FPM type)

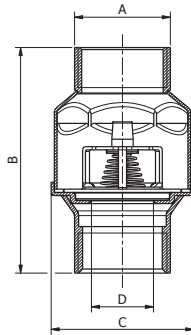
**Dimensioni e pesi /**  
 Dimensions and weights

Codice Code	Misura Size	Materiale Material	DN	PN	Peso in gr. Weight in gr.	KV m³/h	Dimensioni in mm Dimensions in mm			
							A	B	C	D
900012R	3/4"	Aisi 304	20	16	129	10,8	30	67	44	18,3
900017R	1"		25	16	191	18,7	35,8	83	53	23,4
900022R	1" 1/4		32	16	281	31,5	45	97	66	31,4
900402R	3/4"	Aisi 316	20	16	129	10,8	30	67	44	18,3
900412R	1"		25	16	191	18,7	35,8	83	53	23,4
900422R	1" 1/4		32	16	281	31,5	45	97	66	31,4

M1

**Modello / Model**  
**IDRJA / TYPE EA**
**Materiale / Material**  
 Aisi 304

**Tenuta / Seal**  
 FPM

**DN**  
 20 – 50

**PN**  
 16

**Caratteristiche tecniche /**  
 Construction features

- **Versione antinquinamento controllabile** / Antipollution checkable version
- **Conforme a** / In conformity with UNI EN 1717 (tipo / type EA)
- **Foro di ispezione 1/8" gas maschio con tappo su lato aspirazione** / 1/8" male inspection hole with cap on suction side
- **Conessioni filettate femmina secondo** / Threaded ends female according to UNI ISO 228/1
- **Temperatura di esercizio** / Working temperature  
-20°C – +150°C

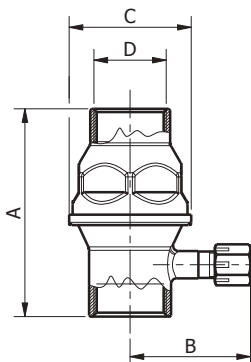
**Dimensioni e pesi /**  
 Dimensions and weights

Codice Code	Misura Size	DN	PN	Peso in gr. Weight in gr.	KV m³/h	Dimensioni in mm Dimensions in mm			
						A	B	C	D
900012T	3/4"	20	16	170	10,8	77	42	44	3/4" F
900017T	1"	25	16	198	18,7	94	45	53	1" F
900022T	1" 1/4	32	16	300	31,5	107	49	66	1" 1/4 F
900027T	1" 1/2	40	16	443	40,5	125	52	78	1" 1/2 F
900030T	2"	50	16	672	56	125	58	90	2" F

M1

**Modello / Model**  
**IDRJA / DW**
**Materiale / Material**  
 Aisi 304 - 316

**Tenuta / Seal**  
 EPDM

**DN**  
 20 - 100

**PN**  
 16



### Caratteristiche tecniche / Construction features

- **Per acqua potabile / For drinkable water**
- **Conforme a / In conformity with**  
UNI EN 1074-3
- **Temperatura di esercizio / Working**  
temperature  
-20°C – +110°C
- **Connessioni filettate femmina secondo /**  
Threaded ends female according to  
UNI ISO 228/1
- **Certificazioni / Approvals**

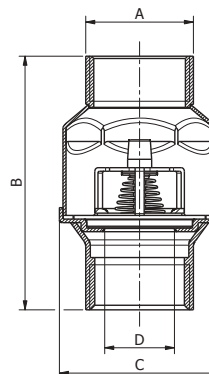

WRAS

NSF/ANSI/CAN 61 &amp; 372

 (solo versione Aisi 304 /  
only Aisi 304 version)

### Dimensioni e pesi / Dimensions and weights

Codice Code	Misura Size	Materiale Material	DN	PN	Peso in gr. Weight in gr.	KV m <sup>3</sup> /h	Dimensioni in mm Dimensions in mm			
							A	B	C	D
900010A	3/4"	Aisi 304	20	16	129	10,8	30	67	44	18,3
900015A	1"		25	16	191	18,7	35,8	83	53	23,4
900020A	1" 1/4		32	16	281	31,5	45	97	66	31,4
900025A	1" 1/2		40	16	388	40,5	50,8	115	78	36,8
900028A	2"		50	16	704	56	63	120,5	89	42,9
900056A	2" 1/2		65	16	1.425	69	80	142	113	58,7
900400A	3/4"	Aisi 316	20	16	129	10,8	30	67	44	18,3
900410A	1"		25	16	191	18,7	35,8	83	53	23,4
900420A	1" 1/4		32	16	281	31,5	45	97	66	31,4
900430A	1" 1/2		40	16	388	40,5	50,8	115	78	36,8
900440A	2"		50	16	704	56	63	120,5	89	42,9
900451A	2" 1/2		65	16	1.425	69	80	142	113	58,7
900461A	3"		80	16	2.085	99	93	160	132	70,3
900471A	4"		100	16	3.415	181	120	191	167	93,4

M1

**Modello / Model**  
**IDRJA / MF**

**Materiale / Material**  
Aisi 304

**Tenuta / Seal**  
FPM

**DN**  
25 – 50

**PN**  
16

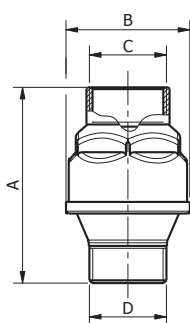

### Caratteristiche tecniche / Construction features

- **Maschio – femmina / Male – female**
- **Connessione lato aspirazione filettata maschio secondo / Threaded ends on suction side male according to UNI ISO 228/1**
- **Connessione lato mandata filettata femmina secondo / Threaded ends on delivery side female according to UNI ISO 228/1**
- **Temperatura di esercizio / Working temperature**  
-20°C – +150°C

### Dimensioni e pesi / Dimensions and weights

Codice Code	Misura Size	DN	PN	Peso in gr. Weight in gr.	KV m <sup>3</sup> /h	Dimensioni in mm Dimensions in mm			
						A	B	C	D
900017MF	1"	25	16	167	18,7	76	53	1" F	1" M
900022MF	1" 1/4	32	16	261	31,5	99	66	1"1/4 F	1"1/4 M
900027MF	1" 1/2	40	16	383	40,5	115	78	1"1/2 F	1"1/2 M
900030MF	2"	50	16	596	56	123	90	2" F	2" M

M1

**Modello / Model**  
**IDRJA / MFA**

**Materiale / Material**  
Aisi 304



**Tenuta / Seal**  
EPDM

**DN**  
25 – 50

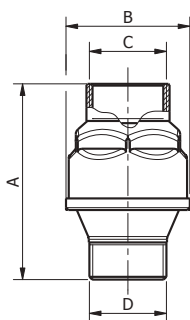
**PN**  
16



### Caratteristiche tecniche / Construction features

- **Maschio – femmina / Male - female**
- **Connessione lato aspirazione filettata maschio / Threaded ends on suction side male**  
UNI ISO 228/1
- **Connessione lato mandata filettata femmina / Threaded ends on delivery side female**  
UNI ISO 228/1
- **Temperatura di esercizio / Working temperature**  
-20°C – +110°C
- **Certificazioni / Approvals**  
 WRAS  
 NSF/ANSI/CAN 61 & 372

### Dimensioni e pesi / Dimensions and weights

Codice Code	Misura Size	DN	PN	Peso in gr. Weight in gr.	KV m <sup>3</sup> /h	Dimensioni in mm Dimensions in mm			
						A	B	C	D
900017MFA	1"	25	16	167	18,7	76	53	1" F	1" M
900022MFA	1" 1/4	32	16	261	31,5	99	66	1" 1/4 F	1" 1/4 M
900027MFA	1" 1/2	40	16	383	40,5	115	78	1" 1/2 F	1" 1/2 M
900030MFA	2"	50	16	596	56	123	90	2" F	2" M

M1

Modello / Model  
**IDRJA / NPT**

Materiale / Material  
Aisi 316

Tenuta / Seal  
FPM

DN  
20 – 50

PN  
16



### Caratteristiche tecniche / Construction features

- **Otturatore con saldatura rinforzata tra perno e disco. Adatta ad uso con aria compressa in applicazioni non gravose** / Flow control disc with reinforced welding between guiding pin and disc for use with compressed air in low impact applications
- **Conessioni filettate femmina gas coniche NPT secondo / Female threaded ends NPT according to ANSI B 1.20.1**

- **Temperatura di esercizio / Working temperature**  
-20°C – +150°C

- **Certificazioni / Approvals**



NSF/ANSI/CAN 61 & 372

### Dimensioni e pesi / Dimensions and weights

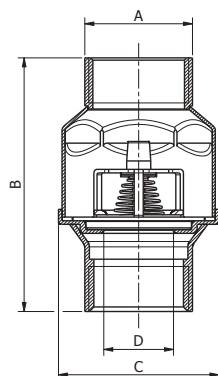

Codice Code	Misura Size	DN	PN	Peso in gr. Weight in gr.	KV m <sup>3</sup> /h	Dimensioni in mm Dimensions in mm			
						A	B	C	D
900402NPTR	3/4"	20	16	129	10,8	30	67	44	18,3
900412NPTR*	1"	25	16	191	18,7	35,8	83	53	23,4
900422NPTR*	1" 1/4	32	16	281	31,5	45	97	66	31,4
900432NPTR*	1" 1/2	40	16	388	40,5	50,8	115	78	36,8
900442NPTR*	2"	50	16	704	56	63	120,5	89	42,9

\* Disponibile versione Maschio/Femmina / Male/Female version available

M1

Modello / Model  
**IDRJA / CON FILTRO E PORTAGOMMA**

Materiale / Material  
Aisi 304

Tenuta / Seal  
NBR

DN  
25 – 50

PN  
16



### Caratteristiche tecniche / Construction features

- **Valvola di fondo con raccordo portagomma** / Foot valve with hose nipple
- **Anello per collegamento galleggiante** / Hook for float connection
- **Grado di filtrazione / Filtration**  
U.S. mesh: 18 (10 per / for 2")
- **Trattamento superficiale: sgrassaggio, decapaggio ed elettrolucidatura** / Surface treatment degreasing, pickling and electropolishing
- **Temperatura di esercizio / Working temperature**  
-20°C – +90°C NBR

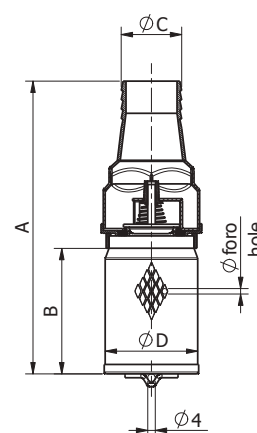

### Dimensioni e pesi / Dimensions and weights

Codice Code	Misura Size	DN	PN	Peso in gr. Weight in gr.	KV m <sup>3</sup> /h	Dimensioni in mm Dimensions in mm				Foro rete Net hole
						A	B	Ø C	Ø D	Ø mm
900037	1"	25	16	175	18,7	157	70	26	49	1
900038	1"	25	16	190	18,7	157	70	32	49	1
900041	1"1/4	32	16	285	31,5	175	70	38	49	1
900043	2"	50	16	690	56	220	82	50	79	1.8



M1

**Modello / Model**  
**IDRJA / FM +**

**Materiale / Material**  
Aisi 304

**Tenuta / Seal**  
NBR

**DN**  
25 – 50

**PN**  
16



### Caratteristiche tecniche / Construction features

- **Femmina-maschio con attacco lato mandata** / Female-male with connection on delivery side
- **Conessioni filettate secondo** / Threaded ends according to UNI ISO 228/1
- **Temperatura di esercizio** / Working temperature  
-25°C – +90°C

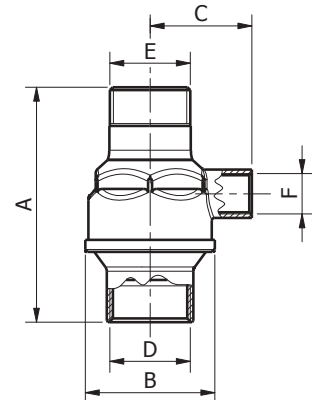

### Dimensioni e pesi / Dimensions and weights

Codice Code	Misura Size	DN	PN	Peso in gr. Weight in gr.	KV m³/h	Dimensioni in mm Dimensions in mm					
						A	B	C	D	E	F
900016A	1"	25	16	200	18,7	97	53	42	1" F	1" M	3/8" F
900021A	1" 1/4	32	16	305	31,5	113	66	48	1"1/4 F	1"1/4 M	3/8" F
900026A	1" 1/2	40	16	430	40,5	130	78	54	1"1/2 F	1"1/2 M	3/8" F
900029A	2"	50	16	660	56	133	90	60	2" F	2" M	3/8" F

M1

**Modello / Model**  
**IDRJA / AMFX**

**Materiale / Material**  
Aisi 316

**Tenuta / Seal**  
EPDM

**DN**  
25 – 50

**PN**  
16



### Caratteristiche tecniche / Construction features

- **Maschio-femmina con attacco lato mandata e lato aspirazione** / Male-female with connections on delivery and suction side
- **Conessioni filettate secondo** / Threaded ends according to UNI ISO 228/1
- **Temperatura di esercizio** / Working temperature  
-20°C – +110°C

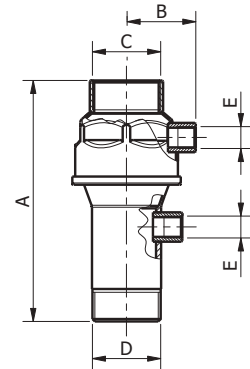

### Dimensioni e pesi / Dimensions and weights

Codice Code	Misura Size	DN	PN	Peso in gr. Weight in gr.	KV m³/h	Dimensioni in mm Dimensions in mm				
						A	B	C	D	E
900410AMFX	1"	25	16	270	18,7	122	39	1" F	1" M	1/4" F
900420AMFX	1" 1/4	32	16	415	31,5	148	44	1"1/4 F	1"1/4 M	1/4" F
900430AMFX	1" 1/2	40	16	530	40,5	152	51	1"1/2 F	1"1/2 M	1/4" F
900440AMFX	2"	50	16	810	56	170	51	2" F	2" M	1/4" F

M1

**Modello / Model**  
IDRJA / 5W

**Materiale / Material**  
Aisi 304

**Tenuta / Seal**  
EPDM

**DN**  
25 – 32

**PN**  
16



### Caratteristiche tecniche / Construction features

- **Maschio-femmina con 3 attacchi lato mandata** / Male-female with 3 connections on delivery side
- **Connessioni filettate secondo** / Threaded ends according to UNI ISO 228/1
- **Temperatura di esercizio** / Working temperature  
-25°C – +110°C

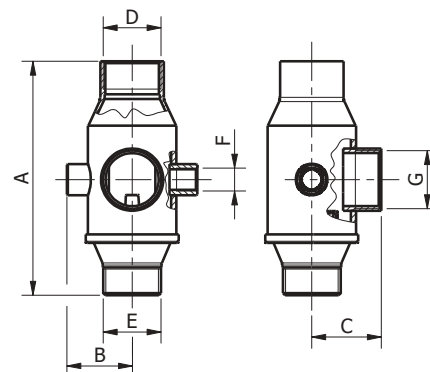

### Dimensioni e pesi / Dimensions and weights

Codice Code	Misura Size	DN	PN	Peso in gr. Weight in gr.	KV m³/h	Dimensioni in mm Dimensions in mm						
						A	B	C	D	E	F	G
900017MFAW	1"	25	16	380	18,7	134	38	40	1" F	1" M	1/4" F	1" F
900022MFAW	1" 1/4	32	16	440	31,5	151	44	45	1"1/4 F	1"1/4 M	1/4" F	1"1/4 F

M1

**Modello / Model**  
IDRJA / VCT

**Materiale / Material**  
Aisi 304

**Tenuta / Seal**  
FPM

**DN**  
25 – 50

**PN**  
16



### Caratteristiche tecniche / Construction features

- **Connessioni tipo** / Ends type  
Victaulic®
- **Temperatura di esercizio** / Working temperature  
-20°C – +150°C

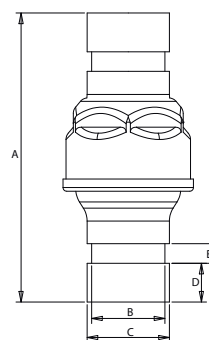

### Dimensioni e pesi / Dimensions and weights

Codice Code	Misura Size	DN	PN	Peso in gr. Weight in gr.	KV m³/h	Dimensioni in mm Dimensions in mm				
						A	B	C	D	E
900017VCT	1"	25	16	210	18,7	120	30	33.7	15.9	8
900022VCT	1" 1/4	32	16	310	31,5	126	38.8	42.4	15.9	8
900027VCT	1" 1/2	40	16	430	40,5	140.7	44.9	48.3	15.9	8
900030VCT	2"	50	16	775	56	160.9	57	60.3	15.9	8

M1

Modello / Model

IDRJA / FLANGIATA

Materiale / Material

Aisi 304 – 316

Tenuta / Seal

FPM

DN

50 – 100

PN

16



### Caratteristiche tecniche / Construction features

■ **Connessioni flangiate: flange in acciaio inox stampato con foratura secondo /**  
Flanged ends: flanges fabricated from pressed stainless steel with holes according to UNI EN 1092-1 PN 16

■ **Temperatura di esercizio / Working temperature**  
-20°C – +150°C

### Dimensioni e pesi / Dimensions and weights

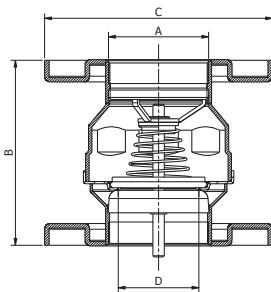

Codice Code	Materiale Material	DN	PN	Peso in gr. Weight in gr.	KV m <sup>3</sup> /h	Dimensioni in mm Dimensions in mm				Flange Flanges	
						A	B	C	D	N° fori N. holes	Diam. fori Diam. holes
900350	Aisi 304	50	16	1.950	56	64	123	165	42,9	4	18
900360		65	16	3.245	69	80	145	185	58,7	4	18
900355	Aisi 316	50	16	1.950	56	64	123	165	42,9	4	18
900365		65	16	3.245	69	80	145	185	58,7	4	18
900375		80	16	4.135	99	93	164	200	70,4	8	18
900385		100	16	6.685	181	120	196	225	93,4	8	18

M1

Modello / Model

IDRJA / DI FONDO

Materiale / Material

Aisi 304 – 316

Tenuta / Seal

FPM

DN

50 – 100

PN

16



### Caratteristiche tecniche / Construction features

■ **Connessione flangiata: flangia in acciaio inox stampato con foratura secondo /**  
Flanged end: flange fabricated from pressed stainless steel with holes according to UNI EN 1092-1 PN 16

■ **Temperatura di esercizio / Working temperature**  
-20°C – +150°C

### Dimensioni e pesi / Dimensions and weights

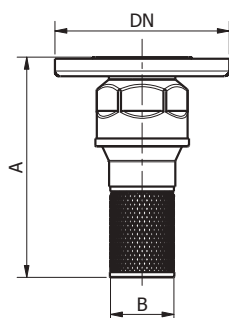

Codice Code	Misura Size	Materiale Material	DN	PN	Peso in gr. Weight in gr.	KV m <sup>3</sup> /h	Dimensioni in mm Dimensions in mm		
							A	B	Ø foro Ø net hole
900350F	2"	Aisi 304	50	16	1.453	56	208	60	1
900360F	2" 1/2		65	16	2.242	69	235	79	1.8
900355F	2"	Aisi 316	50	16	1.453	56	208	60	1
900365F	2" 1/2		65	16	2.242	69	235	79	1.8
900375F	3"		80	16	2.950	99	266	92	1.8
900385F	4"		100	16	5.012	181	321	115	1.8

\* **Misure flangia: vedi tabella superiore /** Flange dimensions: see above table

M1

## IDRJA / DN

**Valvole di ritegno  
in acciaio inox /**  
Stainless steel  
check valves

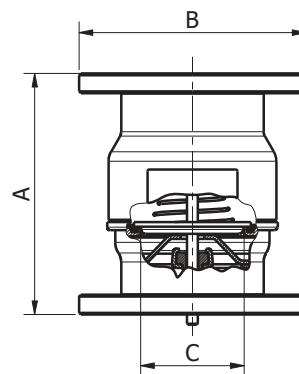
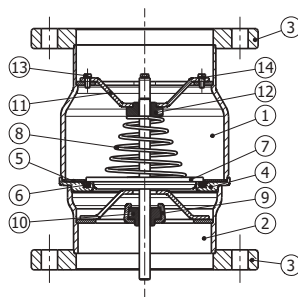

**Modello / Model**  
IDRJA / DN

**Materiale / Material**  
Aisi 316

**Tenuta / Seal**  
FPM

**DN**  
125 – 200

**PN**  
16

### Caratteristiche tecniche / Construction features

- **Lavorazione: acciaio inox stampato /**  
Manufacturing process: pressed stainless steel
- **Trattamento superficiale sgrassaggio,  
decapaggio ed elettrolucidatura /**  
Surface treatment degreasing, pickling and  
electropolishing
- **Tenuta / Seal ring**  
FPM
- **Connessioni flangiate: flange in acciaio  
inox con foratura secondo /** Flanged ends:  
flanges in stainless steel with holes according to  
UNI EN 1092-1 PN 16
- **Saldatura a TIG senza apporto di materiale**  
TIG weldings without additional material
- **Pressione di apertura /** Opening pressure  
Min. 0,035 – Max. 0,065 bar
- **Test idraulico di tenuta guarnizioni /**  
Hydraulic test on the seal rings  
0.2 bar
- **Pressione nominale di esercizio /**  
Nominal working pressure  
16 bar
- **Temperatura di esercizio /** Working  
temperature  
-20°C – +150°C FPM

### Componenti e materiali / Components and materials

<b>1</b>	<b>Corpo valvola superiore /</b> Upper valve body	1.4401 1.4404 EN 10088
<b>2</b>	<b>Corpo valvola inferiore /</b> Lower valve body	1.4401 1.4404 EN 10088
<b>3</b>	<b>Flange /</b> Flanges	1.4401 1.4404 EN 10088
<b>4</b>	<b>Coppa porta guarnizione /</b> Seal ring housing	1.4401 1.4404 EN 10088
<b>5</b>	<b>Anello premi guarnizione /</b> Seal ring retainer	1.4401 1.4404 EN 10088
<b>6</b>	<b>Guarnizione /</b> Seal Ring	FPM
<b>7</b>	<b>Otturatore /</b> Flow control disc	1.4401 1.4404 EN 10088
<b>8</b>	<b>Molla /</b> Spring	1.4401 1.4404 EN 10088
<b>9</b>	<b>Porta boccola inferiore /</b> Lower bush holder	1.4401 1.4404 EN 10088
<b>10</b>	<b>Boccola inferiore /</b> Lower guide bush	PTFE
<b>11</b>	<b>Porta boccola superiore /</b> Upper bush holder	1.4401 1.4404 EN 10088
<b>12</b>	<b>Boccola superiore /</b> Upper guide bush	PTFE
<b>13</b>	<b>Vite TE M5 x 12 /</b> TE M5 x 12 screw	1.4401 1.4404 EN 10088
<b>14</b>	<b>Anello grower /</b> Grower ring	1.4401 1.4404 EN 10088

### Diagramma pressione temperatura / Pressure temperature diagram

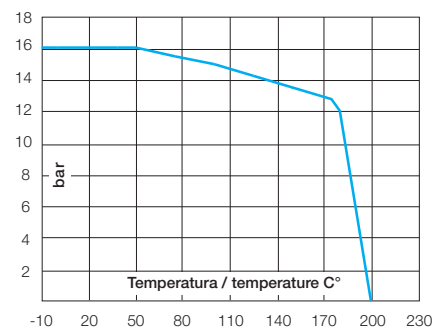

### Perdite di carico / Friction losses diagrams

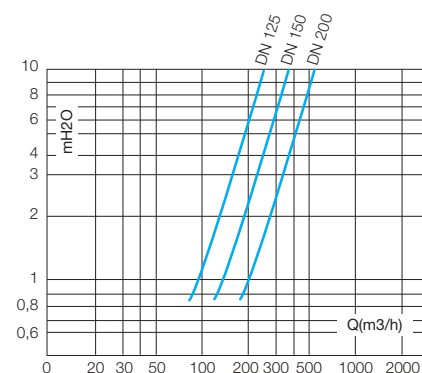

### Dimensioni e pesi / Dimensions and weights

Codice Code	Misura Size	DN	Peso in kg. Weight in kg.	KV m <sup>3</sup> /h	Dimensioni in mm Dimensions in mm		
					A	B	C
900390	5"	125	18	260,16	266	Ø 250	Ø 114
900392	6"	150	24	325	284	Ø 285	Ø 146
900394	8"	200	36	525	318	Ø 340	Ø 188

M1

# IDRJA / AC

**Valvole di ritegno per utilizzi gravosi e aria compressa /**  
 Check valves for heavy duty use and compressed air

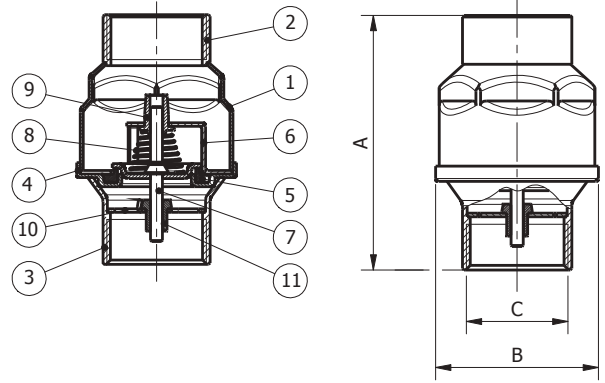

<b>Modello / Model</b> IDRJA / AC	<b>Materiale / Material</b> Aisi 316	<b>Tenuta / Seal</b> FPM	<b>DN</b> 20 – 40	<b>PN</b> 16
--------------------------------------	---	-----------------------------	----------------------	-----------------

### Caratteristiche tecniche / Construction features

- **Usò con aria compressa /** Compressed air systems
- **Otturatore rinforzato e con doppia guida /** Doubled guided reinforced flow control disc
- **Adatta alle sollecitazioni continue /** Suited for heavy-duty use
- **Trattamento superficiale sgrassaggio, decapaggio ed elettrolucidatura /** Surface treatment degreasing, pickling and electropolishing
- **Connessioni filettate femmina secondo /** Threaded ends female according to UNI ISO 228/1
- **Pressione nominale di esercizio /** Nominal working pressure 16 bar
- **Pressione di apertura /** Opening pressure Min. 0,025 – Max. 0,035 bar
- **Temperatura di esercizio /** Working temperature -20°C – +150°C

### Componenti e materiali / Components and materials

<b>1</b>	<b>Corpo / Body</b>	1.4401 1.4404 EN 10088
<b>2</b>	<b>Manicotto lato mandata /</b> Outlet end	1.4401 1.4404 EN 10088
<b>3</b>	<b>Manicotto lato aspirazione /</b> Inlet end	1.4401 1.4404 EN 10088
<b>4</b>	<b>Contenitore anello tenuta /</b> Seal ring housing	1.4401 1.4404 EN 10088
<b>5</b>	<b>Anello di tenuta /</b> Seal ring	FPM
<b>6</b>	<b>Guida otturatore /</b> Flow control disc guide	1.4401 1.4404 EN 10088
<b>7</b>	<b>Otturatore /</b> Flow control disc	1.4401 1.4404 EN 10088
<b>8</b>	<b>Molla /</b> Spring	1.4401 1.4404 EN 10088
<b>9</b>	<b>Boccola guida superiore /</b> Upper guide bush	PTFE
<b>10</b>	<b>Supporto boccola inferiore /</b> Lower bush support	1.4401 1.4404 EN 10088
<b>11</b>	<b>Boccola inferiore /</b> Lower bush	PTFE

### Diagramma pressione temperatura / Pressure temperature diagram

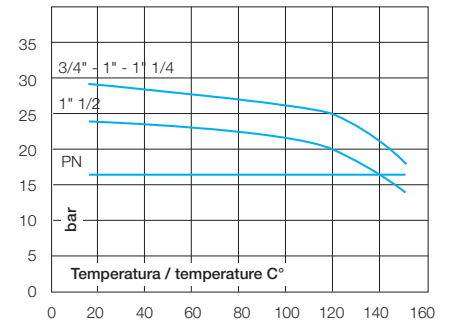

### Perdite di carico / Friction losses diagrams

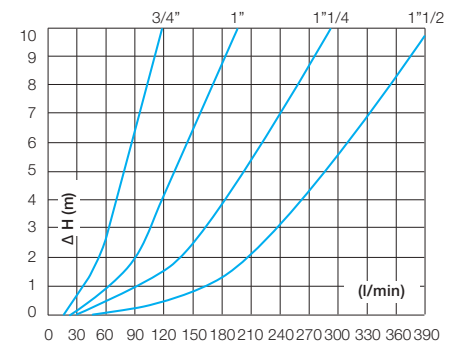

### Dimensioni e pesi / Dimensions and weights

Codice Code	Misura Size	DN	Peso in gr. Weight in gr.	KV m³/h	Dimensioni in mm Dimensions in mm		
					A	B	C
900402AC	3/4"	20	140	7,05	67	44	3/4" F
900412AC	1"	25	170	11,45	83	53	1" F
900422AC	1" 1/4	32	285	16,54	97	66	1"1/4 F
900432AC	1" 1/2	40	410	24,12	115	78	1"1/2 F

M1

# FLOY

**Valvole di ritegno a clapet in acciaio inox stampato** / Swing check valves fabricated from pressed stainless steel

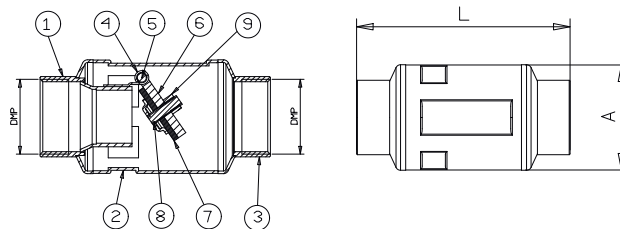

**Modello / Model**  
**FLOY**

**Materiale / Material**  
Aisi 316

**Tenuta / Seal**  
PTFE

**DN**  
15 – 50

**PN**  
16

## Caratteristiche tecniche / Construction features

- **Lavorazione: acciaio inox stampato** / Manufacturing process: pressed stainless steel
- **Trattamento superficiale sgrassaggio, decapaggio ed elettrolucidatura** / Surface treatment degreasing, pickling and electropolishing
- **Connessioni filettate gas femmina secondo** / Threaded ends gas female according UNI ISO 228/1
- **Saldature a TIG senza apporto di materiale** / Welded joints: made with TIG method without any additional material
- **Pressione nominale di esercizio** / Nominal working pressure 16 bar
- **Temperatura di esercizio** / Working temperature -20°C – +200°C

## Componenti e materiali / Components and materials

<b>1</b>	<b>Manicotto lato aspirazione</b> / Inlet end	Acciaio inox / SS Aisi 316
<b>2</b>	<b>Corpo</b> / Body	Acciaio inox / SS Aisi 316
<b>3</b>	<b>Manicotto lato mandata</b> / Outlet end	Acciaio inox / SS Aisi 316
<b>4</b>	<b>Gancio</b> / Hook	Acciaio inox / SS Aisi 316
<b>5</b>	<b>Albero</b> / Stem	Acciaio inox / SS Aisi 316
<b>6</b>	<b>Battente</b> / Disc	Acciaio inox / SS Aisi 316
<b>7</b>	<b>Guarnizione</b> / Seal	PTFE
<b>8</b>	<b>Vite chiusura e contrappeso</b> / Locking screw and counterweight	Acciaio inox / SS Aisi 316
<b>9</b>	<b>Dado M6</b> / Nut M6	Acciaio inox / SS Aisi 316

## Perdite di carico / Friction losses diagrams

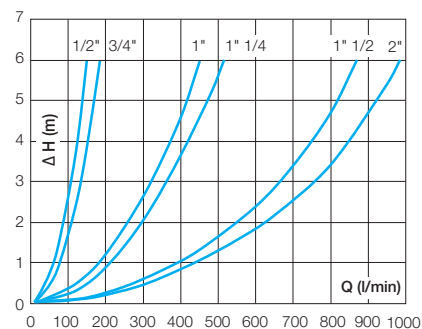

## Dimensioni e pesi / Dimensions and weights

Codice Code	Misura Size	DN	PN	Peso in gr. Weight in gr.	KV m <sup>3</sup> /h	Dimensioni in mm Dimensions in mm	
						A	L
900330	1/2"	15	16	224	8,8	48,3	92
900331	3/4"	20	16	230	10,5	48,3	96
900332	1"	25	16	413	32	63,5	126
900333	1" 1/4	32	16	429	35,5	63,5	126
900334	1" 1/2	40	16	648	83	76,1	139
900335	2"	50	16	680	92	76,1	139

M1

# FLOY / 2.0

**Valvole di ritegno a clapet in acciaio inox stampato ispezionabile /**  
 Inspectable swing check valves fabricated from pressed stainless steel

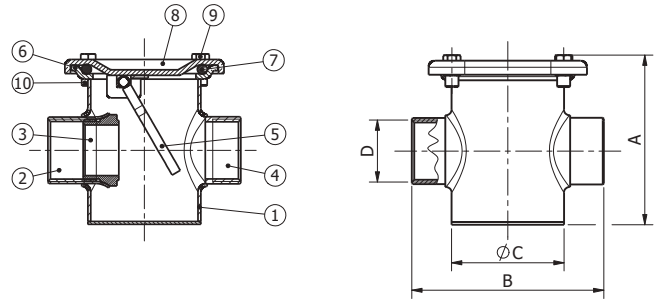

**Modello / Model**  
**FLOY 2.0**

**Materiale / Material**  
 Aisi 316

**Tenuta / Seal**  
 PTFE

**DN**  
 15 – 40

**PN**  
 16

## Caratteristiche tecniche / Construction features

- **Lavorazione: acciaio inox stampato /**  
 Manufacturing process: pressed stainless steel
- **Trattamento superficiale sgrassaggio, decapaggio ed elettrolucidatura /**  
 Surface treatment degreasing, pickling and electropolishing
- **Connessioni filettate gas femmina secondo /**  
 Threaded ends gas female according to UNI ISO 228/1
- **Saldature a TIG senza apporto di materiale /**  
 Welded joints: made with TIG method without any additional material
- **Pressione nominale di esercizio /**  
 Nominal working pressure 16 bar
- **Temperatura di esercizio /**  
 Working temperature -20°C – +180°C

## Componenti e materiali / Components and materials

<b>1</b>	<b>Corpo / Body</b>	Acciaio inox / SS Aisi 316
<b>2</b>	<b>Manicotto lato mandata / Outlet end</b>	Acciaio inox / SS Aisi 316
<b>3</b>	<b>Guarnizione / Seal</b>	PTFE
<b>4</b>	<b>Manicotto lato aspirazione / Inlet end</b>	Acciaio inox / SS Aisi 316
<b>5*</b>	<b>Battente / Disc</b>	Acciaio inox / SS Aisi 316
<b>6</b>	<b>Base coperchio / Cover base</b>	Acciaio inox / SS Aisi 316
<b>7*</b>	<b>Anello OR / O-ring</b>	FPM
<b>8*</b>	<b>Coperchio / Cap</b>	Acciaio inox / SS Aisi 316
<b>9*</b>	<b>Vite TE M5 / TE M5 Screws</b>	Acciaio inox / SS Aisi 304
<b>10</b>	<b>Rivetto / Rivets</b>	Acciaio inox / SS Aisi 304

\* **Ricambi disponibili / Spare parts**

## Dimensioni e pesi / Dimensions and weights

Codice Code	Misura Size	DN	PN	Peso in gr. Weight in gr.	KV m³/h	Dimensioni in mm Dimensions in mm			
						A	B	C	D
900336	1/2"	15	16	370	8,8	73	86	48,3	1/2" F
900337	3/4"	20	16	590	10,5	85	104	60,3	3/4" F
900338	1"	25	16	620	32	91	105	60,3	1" F
900339	1" 1/4	32	16	960	35,5	106	126	76,1	1" 1/4 F
900340	1" 1/2	40	16	1.030	83	112	127	76,1	1" 1/2 F

M1

# AMITA

**Valvole di ritegno  
in plastica / Plastic  
check valves**

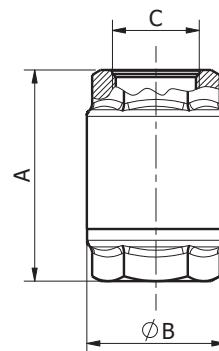
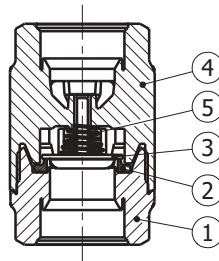

**Modello / Model**  
**AMITA**

**Materiale / Material**  
Pa 66 - Aisi 316

**Tenuta / Seal**  
NBR

**DN**  
15 - 40

**PN**  
6

## Caratteristiche tecniche / Construction features

- **Connessioni filettate femmina secondo /**  
Threaded ends female according  
UNI ISO 228/1
- **Pressione di apertura / Opening pressure**  
Min. 0,025 – Max. 0,035 bar
- **Test idraulico aria compressa su ogni  
valvola a / Hydraulic test compressed air on  
each valve at**  
0,2 bar
- **Pressione nominale di esercizio / Nominal  
working pressure**  
6 bar
- **Temperatura di esercizio / Working  
temperature**  
0°C – +70°C

## Componenti e materiali / Components and materials

<b>1</b>	<b>Corpo inferiore valvola / Lower valve body</b>	Nylon 66 stabilizzato e fibre di vetro 30% / Stabilized nylon 66 and 30% glass fiber
<b>2</b>	<b>Anello di tenuta Seal ring</b>	NBR
<b>3</b>	<b>Otturatore / Flow control disc</b>	Acciaio inox / SS Aisi 316
<b>4</b>	<b>Corpo superiore valvola / Upper valve body</b>	Nylon 66 stabilizzato e fibre di vetro 30% / Stabilized nylon 66 and 30% glass fiber
<b>5</b>	<b>Molla / Spring</b>	Acciaio inox / SS Aisi 316

## Diagramma pressione temperatura / Pressure temperature diagram

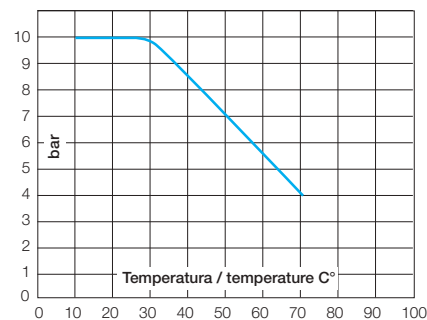

## Dimensioni e pesi / Dimensions and weights

Codice Code	Misura Size	DN	PN	Peso in gr. Weight in gr.	KV m³/h	Dimensioni in mm Dimensions in mm		
						A	B	C
800050	1/2"	15	6	56	5,8	63	40	1/2" F
800051	3/4"	20	6	78	10,5	72	45	3/4" F
800052	1"	25	6	124	17,9	81	54	1" F
800053	1" 1/4	32	6	238	30,1	94	68	1" 1/4 F
800054	1" 1/2	40	6	305	39,2	104	79	1" 1/2 F

## Perdite di carico / Friction losses diagrams

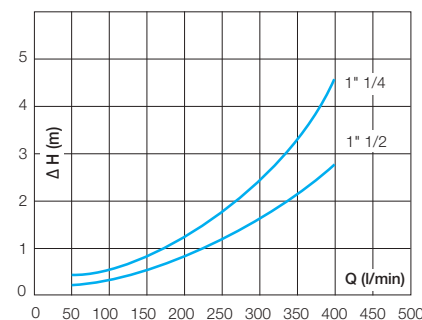
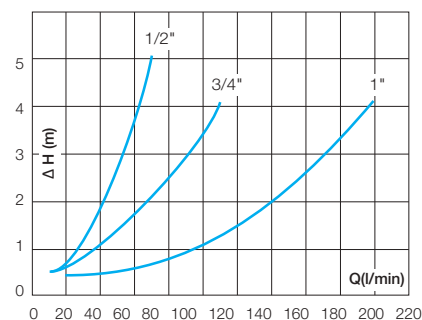



M1

# GLOVALVE

## Valvole di ritegno a palla in acciaio inox stampato /

Ball check valves fabricated from pressed stainless steel

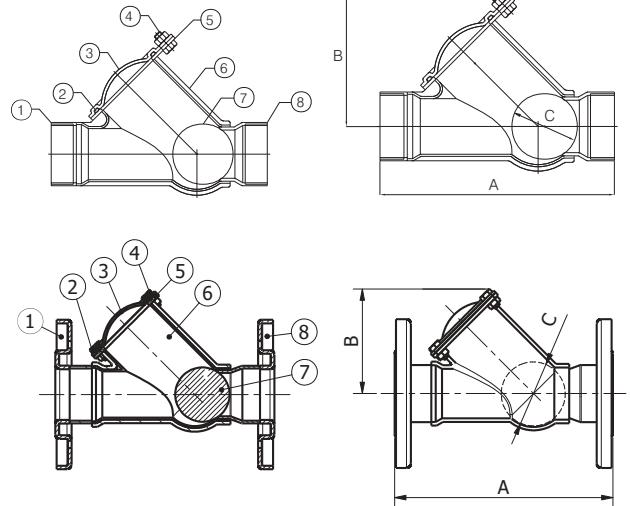

Modello / Model  
**GLOVALVE**

Materiale / Material  
Aisi 316

Tenuta / Seal  
NBR, FPM

DN  
32 – 50

PN  
16

### Caratteristiche tecniche / Construction features

- **Applicazioni: acque reflue, fluidi densi o carichi di elementi in sospensione /**  
Applications: dense and loaded liquids
- **Lavorazione acciaio inox stampato /**  
Manufacturing process pressed stainless steel
- **Trattamento superficiale sgrassaggio, decapaggio ed elettrolucidatura /**  
Surface treatment degreasing, pickling and electropolishing
- **Connessioni filettate femmina secondo /**  
Threaded ends female according to UNI ISO 228/1
- **Versione 2" F con attacchi flangiati in acciaio inox stampato con foratura secondo /**  
F Version 2" available with flanged end from pressed stainless steel with holes according to UNI EN 1092-1 PN 16
- **Saldature a TIG senza apporto di materiale**  
Welded joints TIG method without any additional material
- **Test idraulico su saldature aria compressa su ogni valvola /**  
Hydraulic test on welded joints compressed air on each valve 3 bar
- **Pressione nominale di esercizio /**  
Nominal working pressure 16 bar
- **Temperatura di esercizio /**  
Working temperature 0°C – +90°C NBR  
0°C – +150°C FPM
- **Installazione: verticale e orizzontale /**  
Installation: vertical and horizontal

Su richiesta /  
On request



Filettatura NPT / NPT thread

### Perdite di carico / Friction losses diagrams

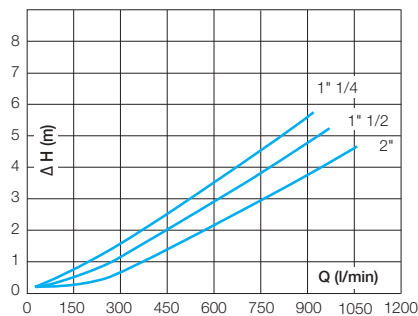

### Componenti e materiali / Components and materials

<b>1</b>	<b>Manicotto mandata /</b> Outlet end	1.4401 EN 10088 (Aisi 316)
<b>2*</b>	<b>OR coperchio flangia /</b> Or seal ring flange	NBR or FPM
<b>3*</b>	<b>Coperchio flangia /</b> Flange cover	1.4401 EN 10088 (Aisi 316)
<b>4*</b>	<b>Dadi e viti</b> Bolts and nuts	1.4401 EN 10088 (Aisi 316)
<b>5</b>	<b>Flangia chiusura /</b> Closing flange	1.4401 EN 10088 (Aisi 316)
<b>6</b>	<b>Corpo /</b> Body	1.4401 EN 10088 (Aisi 316)
<b>7*</b>	<b>Sfera /</b> Ball	Acciaio + NBR or FPM / Iron + NBR or FPM
<b>8</b>	<b>Manicotto aspirazione /</b> Inlet end	1.4401 EN 10088 (Aisi 316)

\* Ricambi disponibili / Spare parts

### Dimensioni e pesi / Dimensions and weights

Codice Code	Misura Size	Tenuta Seal	DN	PN	Peso in kg. Weight in kg.	KV m³/h	Dimensioni in mm Dimensions in mm		
							A	B	C
900210	1" 1/4	NBR	32	16	1,1	29,4	175	99	50
900220	1" 1/2 *		40	16	1,18	57,8	190	99	50
900230	2" *		50	16	1,61	78,3	210	112	60
900230F	DN50		50	16	2,7	78,3	242	112	60
900210V	1" 1/4	FPM	32	16	1,1	29,4	175	99	50
900220V	1" 1/2 *		40	16	1,18	57,8	190	99	50
900230V	2" *		50	16	1,61	78,3	210	112	60
900230VF	DN50		50	16	2,7	78,3	242	112	60

M1

# GLOVALVE / XL

## Valvole di ritegno a palla in acciaio inox stampato /

Ball check valves fabricated from pressed stainless steel

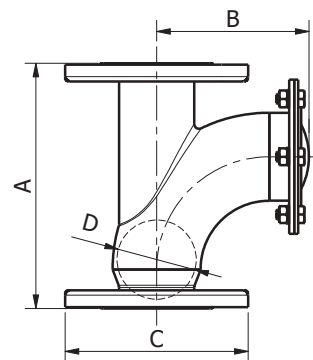
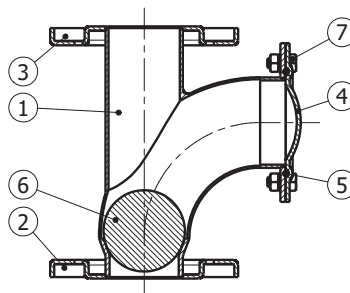

Modello / Model  
**GLOVALVE XL**

Materiale / Material  
Aisi 316

Tenuta / Seal  
NBR

DN  
65 – 100

PN  
10

### Caratteristiche tecniche / Construction features

- **Applicazioni: acque reflue, fluidi densi o carichi di elementi in sospensione /**  
Applications: dense and loaded liquids
- **Lavorazione acciaio inox stampato /**  
Manufacturing process pressed stainless steel
- **Trattamento superficiale sgrassaggio, decapaggio ed elettrolucidatura /**  
Surface treatment degreasing, pickling and electropolishing
- **Attacco flangiato in acciaio inox stampato con foratura secondo /**  
Flanged end from pressed stainless steel with holes according to UNI EN 1092-1 PN 16
- **Saldature a TIG senza apporto di materiale /**  
Welded joints TIG method without any additional material
- **Pressione nominale di esercizio /**  
Nominal working pressure  
10 bar
- **Temperatura di esercizio /**  
Working temperature  
0°C – +90°C NBR
- **Installazione: verticale e orizzontale /**  
Installation: vertical and horizontal

### Componenti e materiali / Components and materials

1	Corpo / Body	1.4401 EN10088 (Aisi 316)
2	Flangia / Flange	1.4401 EN10088 (Aisi 316)
3	Flangia / Flange	1.4401 EN10088 (Aisi 316)
4	Coperchio / Cap	1.4401 EN10088 (Aisi 316)
5	Guarnizione / Seal ring	FPM
6	Palla / Ball	Alluminio + NBR Aluminum + NBR
7	Dadi e viti / Screws and bolts	1.4401 EN10088 (Aisi 316)

### Perdite di carico / Friction losses diagrams

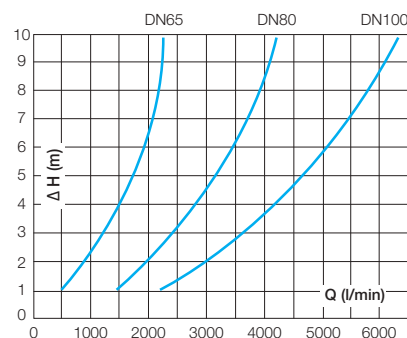

### Dimensioni e pesi / Dimensions and weights

Codice Code	Misura Size	DN	PN	Peso in kg. Weight in kg.	KV m <sup>3</sup> /h	Dimensioni in mm Dimensions in mm					
						A	B	C (UNI EN 1092-1)	D (sfera / ball)	N° fori N. holes	Diam. fori Diam. holes
900240	2"1/2	65	10	5,15	136	250	251	DN 65	80	4	18
900250	3"	80	10	6,98	267	308	297	DN 80	95	8	18
900260	4"	100	10	11,10	396	374	347	DN 100	118	8	18

M2

# CROMAX / AP

Valvole di ritegno a disco per alta pressione / High pressure single disc check valves

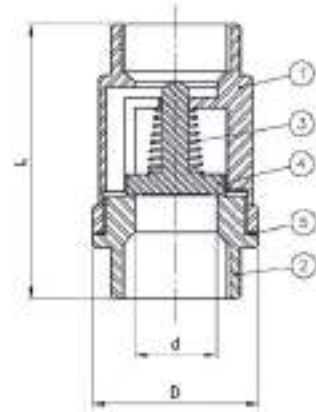

<b>Modello / Model</b> <b>CROMAX AP</b>	<b>Materiale / Material</b> Aisi 316	<b>Tenuta / Seal</b> Metallica - Metallic	<b>DN</b> 8 - 100	<b>PN</b> 63
--	---	--	----------------------	-----------------

## Caratteristiche tecniche / Construction features

- **Connessioni filettate gas femmina secondo** / Threaded ends female gas according to ISO 7-1 (EN 10226-1)
- **Tenuta** / Sealing system Metallo - metallo / Metal to Metal
- **Pressione massima di esercizio** / Maximum working pressure 63 bar
- **Temperatura di esercizio** / Working temperature -20°C - +240°C

## Diagramma pressione temperatura / Pressure temperature diagram

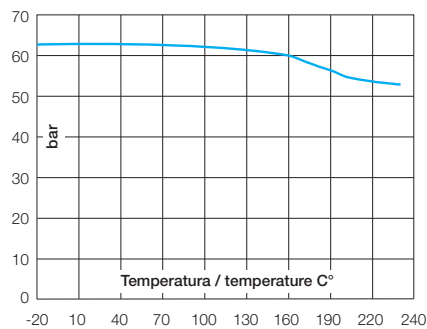

## Componenti e materiali / Components and materials

<b>1</b>	<b>Corpo</b> / Body	Acciaio inox / SS 1.4408
	<b>Trattamento superficiale</b> / Surface treatment	Granigliatura / Shot blasting
<b>2</b>	<b>Corpo aspirazione</b> / Suction body	Acciaio inox / SS 1.4408
	<b>Trattamento superficiale</b> / Surface treatment	Granigliatura / Shot blasting
<b>3</b>	<b>Molla</b> / Spring	Acciaio inox / SS 1.4408
<b>4</b>	<b>Disco</b> / Disc	Acciaio inox / SS 1.4408
	<b>Trattamento superficiale</b> / Surface treatment	Granigliatura / Shot blasting
<b>5</b>	<b>Guarnizione chiusura</b> / Gasket	PTFE

## Dimensioni e pesi / Dimensions and weights

Codice Code	Misura Size	DN	PN	Pressione apertura mbar Opening pressure mbar	Peso in kg. Weight in kg.	KV m³/h	Dimensioni in mm Dimensions in mm		
							d	D	L
H2416M02	1/4"	8	63	80-90	0,17	0,18	8	30,5	53
H2416M03	3/8"	10	63	60-70	0,16	1,11	10	30,5	53
H2416M04	1/2"	15	63	55-65	0,21	3,3	15	37	56
H2416M05	3/4"	20	63	50-60	0,29	7,1	20	42	63
H2416M06	1"	25	63	45-50	0,41	12,7	25	48	74
H2416M07	1" 1/4	32	63	35-40	0,66	14,1	30	58	81
H2416M08	1" 1/2	40	63	25-30	0,99	22,5	38	70	91
H2416M09	2"	50	63	25-30	1,42	31,5	47	82	97
H2416M10	2" 1/2	65	63	25-35	2,60	54	61	102,5	118
H2416M11	3"	80	63	20-25	4,00	75	75	120	138
H2416M12	4"	100	63	20-25	6,95	110	94	150	158

M2

## 9VRU / PG

Valvole di ritegno per alta pressione / High pressure check valves

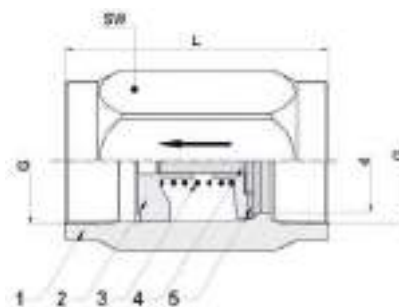

Modello / Model  
**9VRU / PG**

Materiale / Material  
Aisi 316

Tenuta / Seal  
FPM

DN  
8 – 50

PN  
100 – 350

### Caratteristiche tecniche / Construction features

- **Connessioni filettate gas femmina secondo** / Threaded ends female gas according to UNI ISO 228/1
- **Pressione massima di esercizio** / Maximum working pressure 100 – 350 bar
- **Temperatura di esercizio** / Working temperature -20°C – +150°C

### Componenti e materiali / Components and materials

<b>1</b>	<b>Corpo</b> / Body	Acciaio inox / SS Aisi 316
<b>2</b>	<b>Anello di blocco</b> / Blocking ring	Acciaio inox / SS Aisi 316
<b>3</b>	<b>Molla</b> / Spring	Acciaio inox / SS Aisi 316
<b>4</b>	<b>Disco otturatore</b> / Closing disc	Acciaio inox / SS Aisi 316
<b>5</b>	<b>Guarnizione</b> / Seal ring	FPM

### Perdite di carico / Friction losses diagrams

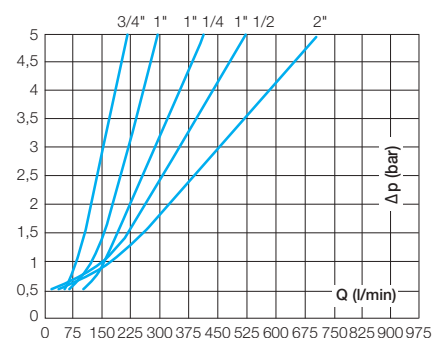
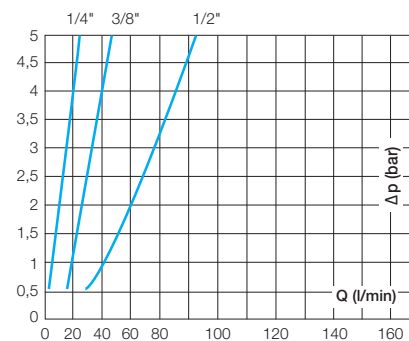

### Dimensioni e pesi / Dimensions and weights

Codice Code	Misura Size	DN	PN	Pressione apertura mbar Opening pressure mbar	Peso in kg. Weight in kg.	KV m³/h	Dimensioni in mm / Dimensions in mm		
							d	SW	L
9VRU/PG-110	1/4"	8	350	500	0,18	0,15	7	19	50
9VRU/PG-120	3/8"	10	350	500	0,17	1,08	10	24	60
9VRU/PG-130	1/2"	15	300	500	0,21	1,25	11	27	65
9VRU/PG-140	3/4"	20	250	500	0,29	4,8	17	34	75
9VRU/PG-150	1"	25	200	500	0,40	7,3	21	41	93
9VRU/PG-160	1" 1/4	32	200	500	0,65	13,3	29	50	110
9VRU/PG-170	1" 1/2	40	125	500	0,98	15	34	55	112
9VRU/PG-180	2"	50	100	500	1,40	25,6	48	75	120

M2

# H2448

**Valvola di ritegno di fondo flangiata / Foot flanged check valve**

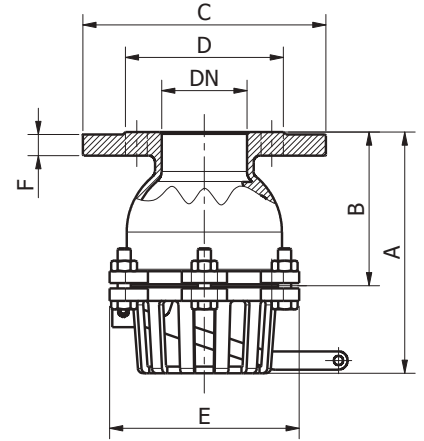
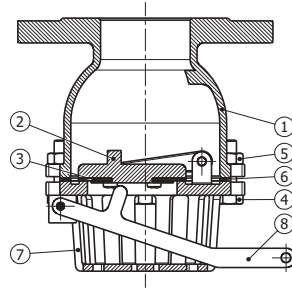

<b>Modello / Model</b> H2448	<b>Materiale / Material</b> Aisi 316	<b>Tenuta / Seal</b> FPM	<b>DN</b> 50 – 200	<b>PN</b> 16
---------------------------------	---	-----------------------------	-----------------------	-----------------

### Caratteristiche tecniche / Construction features

- **Attacco flangiato secondo /** Flange end according to DIN 2501 PN-16
- **Sistema manuale di svuotamento /** Manual system to empty
- **Pressione massima di esercizio /** Maximum working pressure 16 bar
- **Temperatura di esercizio /** Working temperature -30°C – +180°C

### Diagramma pressione temperatura / Pressure temperature diagram

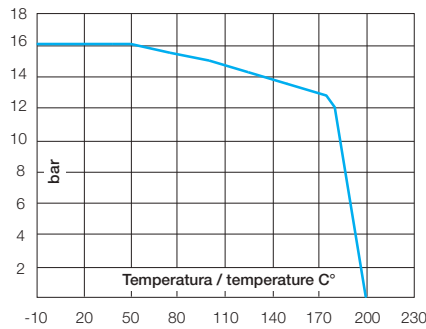

### Perdite di carico / Friction losses diagrams

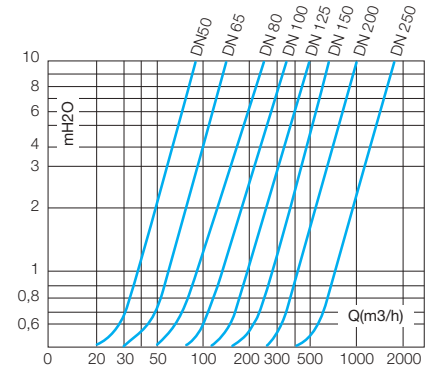

### Componenti e materiali / Components and materials

<b>1</b>	<b>Corpo / Body</b>	Acciaio inox / SS Aisi 316
<b>2</b>	<b>Otturatore / Disc</b>	Acciaio inox / SS Aisi 316
<b>3*</b>	<b>Tenuta / Seal</b>	FPM
<b>4</b>	<b>Vite / Bolt</b>	Acciaio inox / SS Aisi 316
<b>5</b>	<b>Dado / Nut</b>	Acciaio inox / SS Aisi 316
<b>6*</b>	<b>Guarnizione / Seal</b>	PTFE
<b>7</b>	<b>Filtro / Strainer</b>	Acciaio inox / SS Aisi 316
<b>8</b>	<b>Leva / Handwheel</b>	Acciaio inox / SS Aisi 316

\* Ricambi disponibili / Spare parts

### Dimensioni e pesi / Dimensions and weights

Codice Code	Misura Size	DN	PN	Pressione apertura mbar Opening pressure mbar	Peso in kg. Weight in kg.	KV m³/h	Dimensioni in mm Dimensions in mm					
							A	B	C	D	E	F
H244809	2"	50	16	15	5,2	78	170	107	165	102	150	18
H244810	2" 1/2	65	16	17	6,9	145	183	115	185	122	170	18
H244811	3"	80	16	16	9,4	230	198	127	200	138	186	20
H244812	4"	100	16	15	14,6	319	242	157	220	158	229	20
H244813	5"	125	16	21	19,4	489	282	182	250	188	269	22
H244814	6"	150	16	20	28,9	605	326	210	285	212	296	22
H244816	8"	200	16	21	52,1	978	440	304	340	268	369	24

M2

90030

**Valvole di ritegno  
a disco tipo wafer /**  
Wafer disc check  
valves

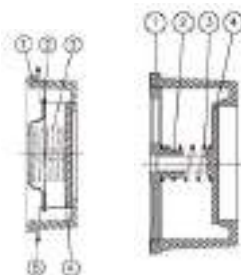

DN 15 - 100    DN 125 - 200

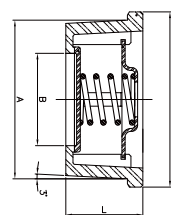
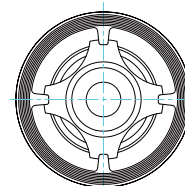

**Modello / Model**  
90030

**Materiale / Material**  
Aisi 316

**Tenuta / Seal**  
Metallica / Metallic

**DN**  
15 - 200

**PN**  
25 - 40

### Caratteristiche tecniche / Construction features

- **Montaggio tra flange secondo** / Assembly between flanges according to EN 1092 PN10/16/25/40 - ANSI 150/300
- **Scartamento tra le facce** / Face to face according to EN 558-1 S.49.
- **Pressione nominale di esercizio** / Nominal working pressure 40 bar (25 bar per/for DN125, 150 e/and 200)
- **Temperatura di esercizio** / Working temperature -20°C - +240°C
- **Installazione orizzontale, verticale o inclinata** / Installation: horizontal, vertical or inclined flow

### Diagramma pressione temperatura / Pressure temperature diagram

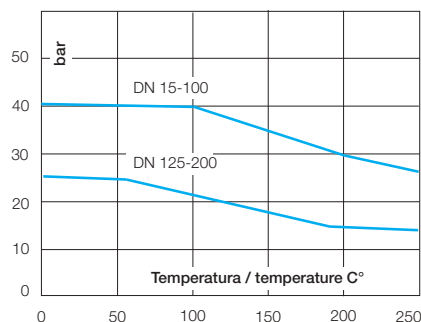

### Perdite di carico / Friction losses diagrams

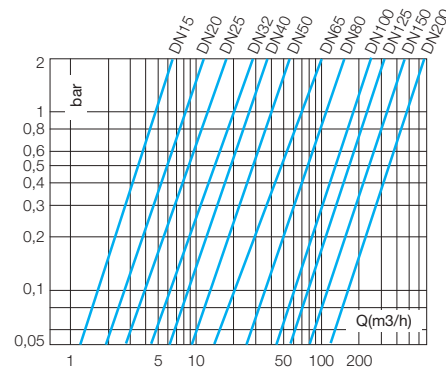

### Dimensioni e pesi / Dimensions and weights

Codice Code	Misura Size	DN	PN	Pressione apertura mbar Opening pressure mbar	Peso in gr. Weight in gr.	KV m³/h	Dimensioni in mm Dimensions in mm			
							D	A	B	L
900300	1/2"	15	40	24-30	85	4,9	39	34	15	16
900301	3/4"	20	40	24-30	122	8,8	46	41	20	19
900302	1"	25	40	24-30	198	11,2	54	49	25	22
900303	1" 1/4	32	40	24-30	380	20,7	70	62	32	28
900304	1" 1/2	40	40	24-30	520	29	81	71	40	32
900305	2"	50	40	24-30	775	40	94	85	48	40
900306	2" 1/2	65	40	24-30	1.240	57	113	102	62	46
900307	3"	80	40	20-26	1.865	85	132	123	75	50
900308	4"	100	40	20-26	2.650	92	150	140	95	60
900309	5"	125	25	30-36	5.500	192	187	177	118	90
900310	6"	150	25	30-36	8.300	255	217	205	140	106
900311	8"	200	25	30-36	16.100	425	274	261	185	140

### Componenti e materiali / Components and materials

1	<b>Corpo</b> / Body	Acciaio inox / SS 1.4408
	<b>Trattamento superficiale</b> / Surface treatment	Granigliatura / Shot blasting
2	<b>Disco porta molla</b> / Spring stopper	Acciaio inox / SS Aisi 316
3*	<b>Molla</b> / Spring	Acciaio inox / SS Aisi 316
4	<b>Otturatore</b> / Disc	Acciaio inox / SS Aisi 316
	<b>Trattamento superficiale</b> / Surface treatment	Lucidatura / Polishing
5	<b>Anello centraggio</b> / Centring ring	Acciaio inox / SS Aisi 304

\* **Ricambi disponibili** / Spare parts

M2

90032

Valvole di ritegno a  
clapet / Swing check  
valves

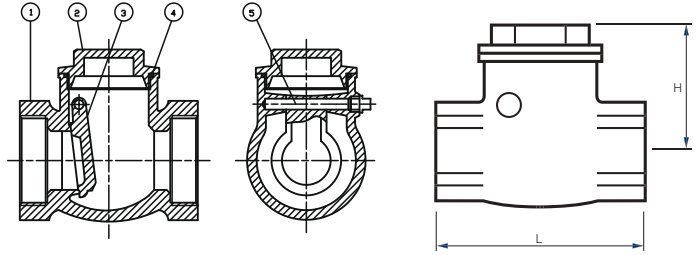

Modello / Model  
**90032**

Materiale / Material  
Aisi 316

Tenuta / Seal  
Metallica / Metallic

DN  
15 - 50

PN  
16

### Caratteristiche tecniche / Construction features

- **Connessioni filettate femmina secondo /**  
Female threaded ends according to  
ISO 7-1 (EN 10226-1)
- **Pressione nominale di esercizio /**  
Nominal working pressure  
16 bar
- **Temperatura di esercizio /**  
Working temperature  
-25°C - +180°C
- **Installazione orizzontale o verticale /**  
Installation horizontal or vertical flow

### Componenti e materiali / Components and materials

<b>1</b>	<b>Corpo / Body</b>	Acciaio inox / SS 1.4408
	<b>Trattamento superficiale / Surface treatment</b>	Granigliatura / Shot blasting
<b>2</b>	<b>Coperchio / Cap</b>	Acciaio inox / SS 1.4408
	<b>Trattamento superficiale / Surface treatment</b>	Granigliatura / Shot blasting
<b>3</b>	<b>Disco / Disc</b>	Acciaio inox / SS 1.4408
<b>4</b>	<b>Guarnizione coperchio / Cover seal</b>	PTFE
<b>5</b>	<b>Perno / Stem</b>	Acciaio inox / SS Aisi 316

### Diagramma pressione temperatura / Pressure temperature diagram

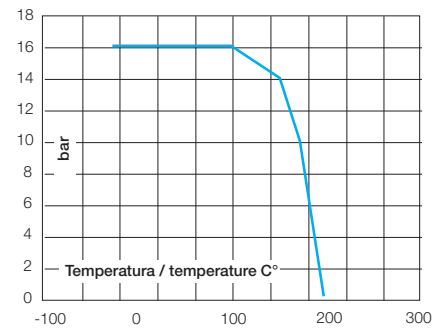

### Dimensioni e pesi / Dimensions and weights

Codice Code	Misura Size	DN	PN	Peso in gr. Weight in gr.	KV m³/h	Dimensioni in mm Dimensions in mm	
						L	H
900320	1/2"	15	16	312	2,2	65	44
900321	3/4"	20	16	490	4,4	80	53
900322	1"	25	16	724	8,2	90	58
900323	1" 1/4	32	16	1.042	16,4	105	62
900324	1" 1/2	40	16	1.650	24,1	120	73
900325	2"	50	16	2.392	44,2	141	78

### Perdite di carico / Friction losses diagrams

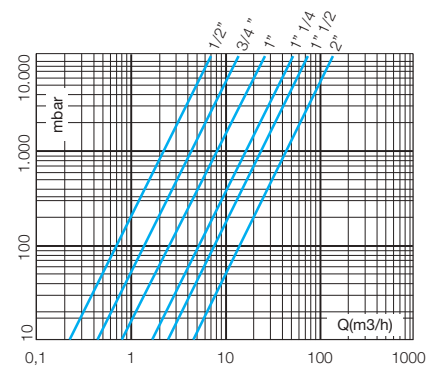

Su richiesta /  
On request



Filettatura NPT / NPT thread

M2

## H2406

Valvole di ritegno a clapet  
tipo wafer / Wafer swing  
check valves

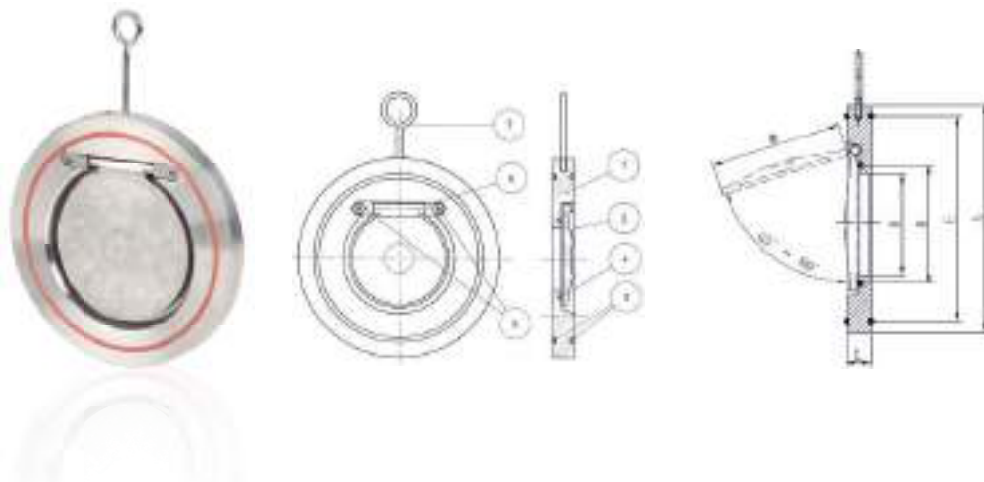

<b>Modello / Model</b> H2406	<b>Materiale / Material</b> Aisi 316	<b>Tenuta / Seal</b> FPM	<b>DN</b> 40 – 300	<b>PN</b> 16
---------------------------------	---	-----------------------------	-----------------------	-----------------

### Caratteristiche tecniche / Construction features

- **Montaggio tra flange secondo** / Assembly between flanges according to EN 1092 PN10/16 - ANSI 150
- **Pressione nominale di esercizio** / Nominal working pressure 16 bar
- **Temperatura di esercizio** / Working temperature -20°C – +180°C
- **Installazione orizzontale o verticale** / Installation horizontal or vertical flow

### Diagramma pressione temperatura / Pressure temperature diagram

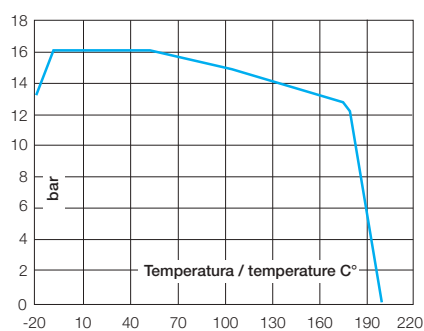

### Perdite di carico / Friction losses diagrams

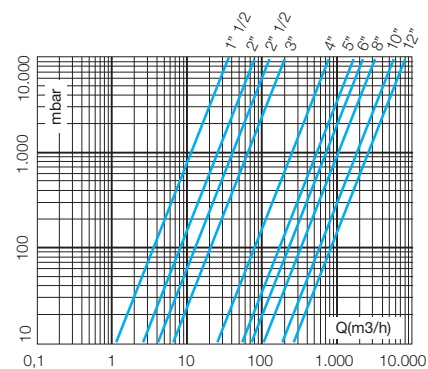

### Componenti e materiali / Components and materials

<b>1</b>	<b>Corpo / Body</b>	Acciaio inox / SS 1.4408
	<b>Trattamento superficiale / Surface treatment</b>	Granigliatura / Shot blasting
<b>2</b>	<b>Disco / Disc</b>	Acciaio inox / SS 1.4408
	<b>Trattamento superficiale / Surface treatment</b>	Granigliatura / Shot blasting
<b>3*</b>	<b>OR esterno / Ext. O ring</b>	FPM
<b>4*</b>	<b>OR disco / Disc O ring</b>	FPM
<b>5</b>	<b>Vite asse / Axis screw</b>	Acciaio inox / SS Aisi 316
<b>6</b>	<b>Fermo asse / Stem stopped</b>	Acciaio inox / SS Aisi 316
<b>7</b>	<b>Gancio / Hook</b>	Acciaio zincato / Zinc plated st.

\* **Ricambi disponibili** / Spare parts

### Dimensioni e pesi / Dimensions and weights

Codice Code	Misura Size	DN	PN	Pressione apertura Opening pressure mbar	Peso in gr. Weight in gr.	KV m³/h	Dimensioni in mm Dimensions in mm					
							A	B	D	E	L	Ø
H240608	1" 1/2	40	16	0 – 6	450	11,5	85	33	25	68	12	40
H240609	2"	50	16	0 – 6	790	25,5	105	41	32	84	14	47.5
H240610	2" 1/2	65	16	0 – 6	1.110	42,5	124	51	40	96	14	63
H240611	3"	80	16	0 – 6	1.340	68	136	65	54	118	14	74
H240612	4"	100	16	0 – 6	2.300	248	164	85	70	148	18	92
H240613	5"	125	16	0 – 6	3.100	550,5	194	106	92	166	18	116
H240614	6"	150	16	0 – 6	4.500	729	220	130	114	197	20	138
H240616	8"	200	16	0 – 9	7.150	1045	275	170	154	249	22	179
H240618	10"	250	16	0 – 9	11.950	1907	330	220	200	310	26	230
H240620	12"	300	16	0 – 9	20.500	2720	384	255	230	358	30	270



M2

# H2402

**Valvole di ritegno wafer doppio battente /**  
Double disc wafer check valves

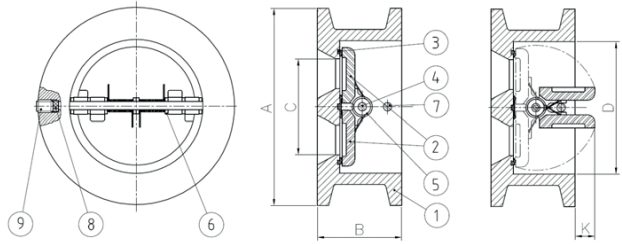

<b>Modello / Model</b> H2402	<b>Materiale / Material</b> Aisi 316	<b>Tenuta / Seal</b> FPM	<b>DN</b> 50 – 300	<b>PN</b> 25
---------------------------------	---	-----------------------------	-----------------------	-----------------

## Caratteristiche tecniche / Construction features

- **Montaggio tra flange secondo /**  
Assembly between flanges according to  
EN 1092 PN25 – ANSI 150  
EN 1092 PN10 – PN16  
(fino a / up to DN200)
- **Scartamento tra le facce /**  
Face to face according to  
EN 558-1
- **Pressione nominale di esercizio /**  
Nominal working pressure  
25 bar
- **Temperatura di esercizio / Working**  
temperature  
-20°C – +180°C

## Diagramma pressione temperatura / Pressure temperature diagram

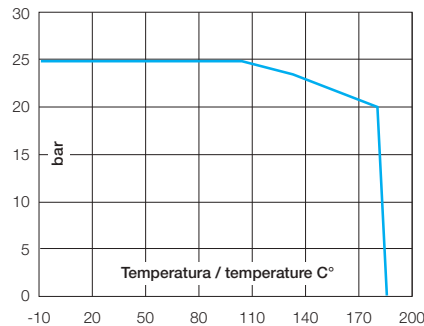

## Perdite di carico / Friction losses diagrams

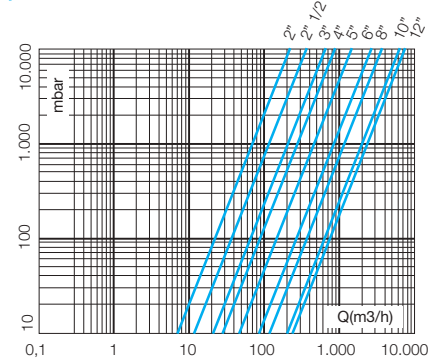

## Componenti e materiali / Components and materials

<b>1</b>	<b>Corpo / Body</b>	Acciaio inox / SS 1.4408
	<b>Trattamento superficiale / Surface treatment</b>	Granigliatura / Shot blasting
<b>2</b>	<b>Disco / Disc</b>	Acciaio inox / SS 1.4408
	<b>Trattamento superficiale / Surface treatment</b>	Granigliatura / Shot blasting
<b>3</b>	<b>Tenuta / Seal</b>	FPM
<b>4*</b>	<b>Asse / Axle</b>	Acciaio inox / SS Aisi 316
<b>5*</b>	<b>Molla / Spring</b>	Acciaio inox / SS Aisi 316
<b>6</b>	<b>Rondella / Washer</b>	PTFE
<b>7</b>	<b>Fermo corsa / Disc Stopper</b>	Acciaio inox / SS Aisi 316
<b>8*</b>	<b>Tappo / Plug</b>	FPM
<b>9*</b>	<b>Vite / Grub Screw</b>	Acciaio inox / SS Aisi 304

\* **Ricambi disponibili / Spare parts**

## Dimensioni e pesi / Dimensions and weights

Codice Code	Misura Size	DN	PN	Pressione apertura mbar Opening pressure mbar	Peso in kg. Weight in kg.	KV m³/h	Dimensioni in mm Dimensions in mm				
							A	B	C	D	K
H240209	2"	50	25	0,4 - 22,8	1,3	68	101	54	48	66	5
H240210	2" 1/2	65	25	0,4 - 22,8	1,8	111	119	54	59	80	11
H240211	3"	80	25	0,4 - 22,8	2,4	206	133	57	72	95	11
H240212	4"	100	25	0,5 - 24	3,9	266	164	64	90	117	24
H240213	5"	125	25	0,5 - 24,5	6,3	455	194	70	110	145	34
H240214	6"	150	25	0,6 - 24,7	8,1	813	220	76	135	170	43
H240216	8"	200	25	0,7 - 25,4	15,5	1132	275	95	175	224	67
H240218	10"	250	25	0,8 - 26,6	21,3	1950	337	108	215	255	80
H240220	12"	300	25	0,9 - 27,3	34	2300	400	143	254	302	96

M3

## H2401

Valvole di ritegno wafer a doppio battente / Double disc wafer check valves

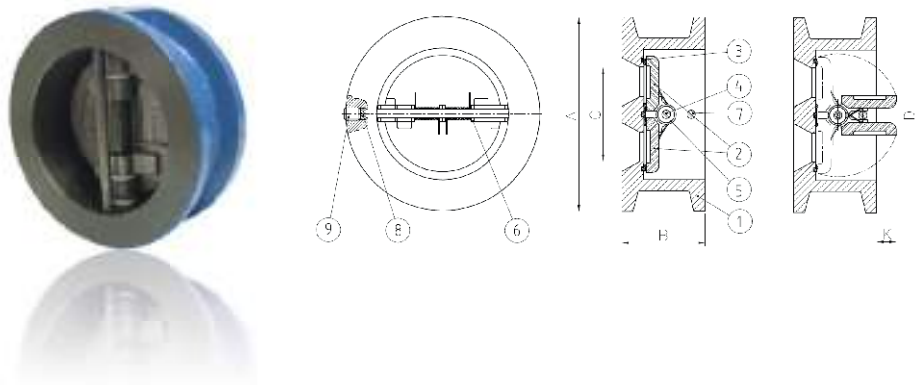

Modello / Model  
**H2401**

Materiale / Material  
Ghisa / Cast Iron EN-GJL-250

Tenuta / Seal  
NBR

DN  
50 - 300

PN  
16

### Caratteristiche tecniche / Construction features

- **Montaggio tra flange secondo** / Assembly between flanges according to ANSI 150 - EN 1092 PN 10/16
- **Scartamento tra le facce** / Face to face according to EN 558-1
- **Temperatura di esercizio** / Working temperature -10°C + 100°C

### Componenti e materiali / Components and materials

1	<b>Corpo</b> / Body	Ghisa / Cast Iron EN-GJL-250
2	<b>Disco</b> / Disc	Acciaio inox / SS 1.4408
3	<b>Tenuta</b> / Seal	NBR
4	<b>Asse</b> / Axle	Acciaio inox / SS Aisi 316
5*	<b>Molla</b> / Spring	Acciaio inox / SS Aisi 316
6*	<b>Rondella</b> / Washer	PTFE
7	<b>Fermo corsa</b> / Stopper	Acciaio inox / SS Aisi 316
8*	<b>Tappo</b> / Plug	NBR
9*	<b>Vite</b> / Grub Screw	Acciaio inox / SS Aisi 304

\* **Ricambi disponibili** / Spare parts

### Diagramma pressione temperatura / Pressure temperature diagram

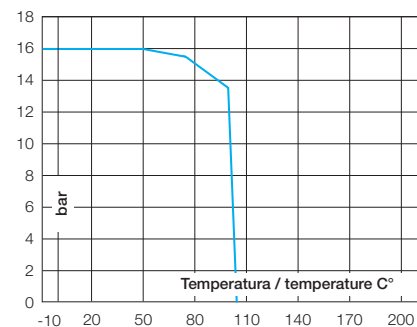

### Dimensioni e pesi / Dimensions and weights

Codice Code	Misura Size	DN	PN	Pressione apertura mbar Opening pressure mbar	Peso in kg. Weight in kg.	KV m³/h	Dimensioni in mm Dimensions in mm				
							A	B	C	D	K
H240109	2"	50	16	0,4 - 22,8	1,5	68	101	54	48	66	5
H240110	2" 1/2	65	16	0,4 - 22,8	2,05	111	119	54	59	80	11
H240111	3"	80	16	0,4 - 22,8	2,7	206	133	57	72	95	11
H240112	4"	100	16	0,5 - 24	4,1	266	164	64	90	117	24
H240113	5"	125	16	0,5 - 24,5	6,45	455	194	70	110	145	34
H240114	6"	150	16	0,6 - 24,7	8,2	813	220	76	135	170	43
H240116	8"	200	16	0,7 - 25,4	15,8	1.132	275	95	175	224	67
H240118	10"	250	16	0,8 - 26,6	23,5	1.950	328	108	215	255	80
H240120	12"	300	16	0,9 - 27,3	42,5	2.300	378	143	254	302	96

### Perdite di carico / Friction losses diagrams

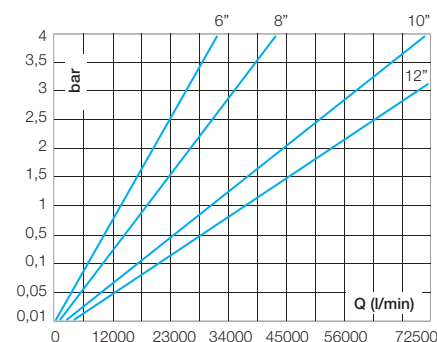
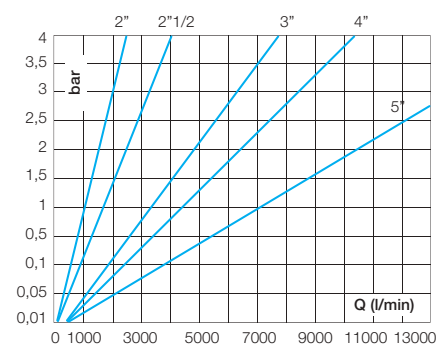

M3

# RE-GE

Valvole di ritegno in ottone / Brass check valves

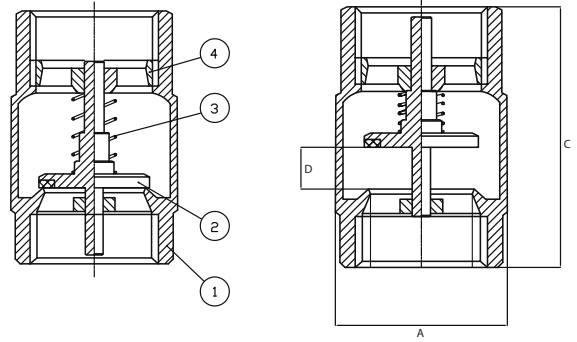

<b>Modello / Model</b> <b>RE-GE</b>	<b>Materiale / Material</b> Ottone / Brass	<b>Tenuta / Seal</b> NBR	<b>DN</b> 15 – 100	<b>PN</b> 25-12
--	---	-----------------------------	-----------------------	--------------------

### Caratteristiche tecniche / Construction features

- **Valvole di ritegno monoblocco smontabili (solo fino a 2")** / Removable and monobloque (only up to 2") check valve
- **Conessioni filettate gas femmina secondo** / Threaded ends female gas according to UNI ISO 228/1
- **Pressione minima di apertura** / Minimum opening pressure 0,04 bar
- **Pressione nominale di esercizio** / Nominal working pressure  
25 bar (da/from 1/2" a/to 1")  
18 bar (da/from 1" 1/4 a/to 2")  
12 bar (da/from 2"1/2 a/to 4")
- **Temperatura di esercizio** / Working temperature  
-20°C – +100°C Aria / Air  
-20°C – +60°C Gas  
0°C – +100°C Acqua / Water

### Dimensioni e pesi / Dimensions and weights

Codice Code	Misura Size	DN	PN	Peso in gr. Weight in gr.	KV m³/h	Dimensioni in mm Dimensions in mm		
						ØA	C	D
931204	1/2"	15	25	110	4,74	30,0	50,0	7,5
931205	3/4"	20	25	175	8,7	36,5	57,0	8,5
931206	1"	25	25	260	13,61	43,0	65,0	10,5
931207	1" 1/4	32	18	375	21,38	53,0	70,0	11
931208	1" 1/2	40	18	525	31,63	64,5	75,5	12
931209	2"	50	18	800	46,7	79,5	81,5	14
931210	2"1/2	65	12	1.555	78,77	104	104	22
931211	3"	80	12	2.335	111,5	124	113	23,5
931212	4"	100	12	3.665	176,9	155	132	27

### Componenti e materiali / Components and materials

<b>1</b>	<b>Corpo / Body</b>	Ottone forgiato conforme a / Hot-forged brass according to UNI-EN 12165
<b>2</b>	<b>Otturatore / Flow control disc</b>	Ottone + NBR / Brass + NBR
<b>3</b>	<b>Molla / Spring</b>	Acciaio inox / SS Aisi 304
<b>4</b>	<b>Anello Chiusura / Closing Ring</b>	Ottone / Brass

### Diagramma pressione temperatura / Pressure temperature diagram

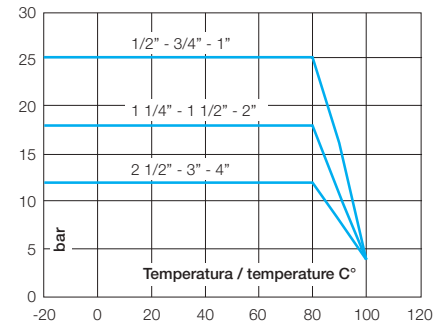

### Perdite di carico / Friction losses diagrams

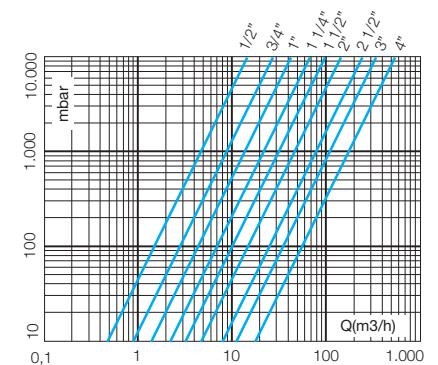

Su richiesta / On request



Filettatura NPT / NPT thread

M3

# RE-GE / PLUS

Valvole di ritegno  
in ottone cromato /  
Chromed brass check  
valves

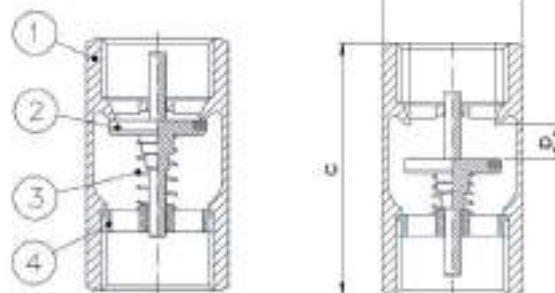

Modello / Model  
**RE-GE PLUS**

Materiale / Material  
Ottone / Brass

Tenuta / Seal  
NBR

DN  
15 – 50

PN  
25 – 18

## Caratteristiche tecniche / Construction features

- **Valvole di ritegno monoblocco smontabili** / One-piece disassemblable check valves
- **Connessioni filettate gas femmina secondo** / Threaded ends female gas according UNI ISO 228/1
- **Pressione minima di apertura** / Minimum opening pressure 0,04 bar
- **Pressione nominale di esercizio** / Nominal working pressure 25 bar (da/from 1/2" a/to 1") 18 bar (da/from 1" 1/4 a/to 2")
- **Temperatura di esercizio** / Working temperature -20°C – +100°C Aria / Air -20°C – +60°C Gas 0°C – +90°C Acqua / Water

## Componenti e materiali / Components and materials

<b>1</b>	<b>Corpo</b> / Body	Ottone forgiato conforme a / Hot-forged brass according to UNI-EN 12165
<b>2</b>	<b>Otturatore</b> / Flow control disc	Ottone + NBR / Brass + NBR
<b>3</b>	<b>Molla</b> / Spring	Acciaio inox / SS Aisi 304
<b>4</b>	<b>Anello Chiusura</b> / Closing Ring	Ottone / Brass

## Diagramma pressione temperatura / Pressure temperature diagram

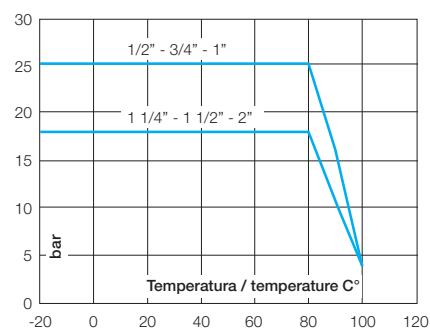

## Dimensioni e pesi / Dimensions and weights

Codice Code	Misura Size	DN	PN	Peso in gr. Weight in gr.	KV m <sup>3</sup> /h	Dimensioni in mm Dimensions in mm		
						Ø A	C	D
H3122P04	1/2"	15	25	110	6,05	27.5	57	7.8
H3122P05	3/4"	20	25	190	9,7	34.5	64	10.8
H3122P06	1"	25	25	285	15,5	42	75	10.3
H3122P07	1" 1/4	32	18	405	22,1	51.5	82	12.4
H3122P08	1" 1/2	40	18	583	35,3	62.5	93	13
H3122P09	2"	50	18	885	50,6	77.5	100	15

## Perdite di carico / Friction losses diagrams

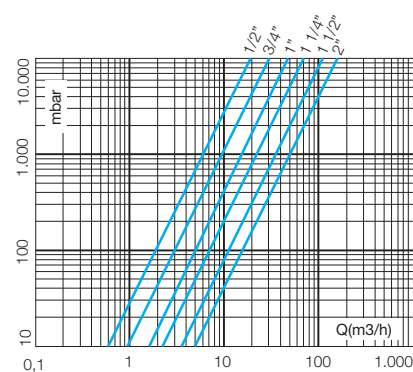

M3

# H2450

**Valvole di ritegno flangiate in ghisa / Cast iron flanged check valves**

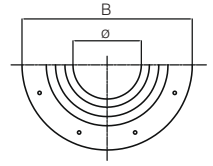
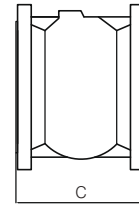
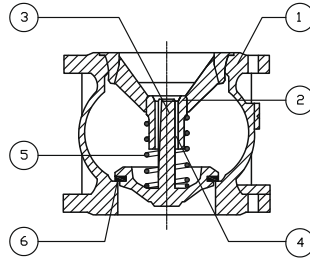

<b>Modello / Model</b> H2450	<b>Materiale / Material</b> Ghisa-ottone / Cast iron-brass	<b>Tenuta / Seal</b> NBR	<b>DN</b> 50 – 250	<b>PN</b> 16
---------------------------------	---	-----------------------------	-----------------------	-----------------

### Caratteristiche tecniche / Construction features

- **Montaggio tra flange secondo / Assembly** between flanges according to DIN 2501 PN 16
- **Guida e otturatore / Stem and guide** fino a/until DN 100 ottone / brass da/from DN 125 a/to DN 250 ghisa / cast iron GG25
- **Pressione nominale di esercizio / Nominal working pressure** 16 bar
- **Temperatura di esercizio / Working temperature** -10°C – +100°C
- **Chiusura silenziosa / Silent closing**
- **Installazione orizzontale o verticale / Installation horizontal or vertical flow**

### Componenti e materiali / Components and materials

<b>1</b>	<b>Corpo / Body</b>	Ghisa GG-25 / Cast Iron GG-25
	<b>Trattamento superficiale / Surface treatment</b>	Verniciatura / Painting
<b>2</b>	<b>Guida / Guide</b>	Ottone (fino a DN 100) o ghisa / Brass (up to DN100) or cast iron
	<b>Trattamento superficiale / Surface treatment</b>	Nichelatura / Nickel plated
<b>3</b>	<b>Otturatore / Guiding stem</b>	Ottone (fino a DN 100) o ghisa / Brass (up to DN100) or cast iron
	<b>Trattamento superficiale / Surface treatment</b>	Nichelatura / Nickel plated
<b>4</b>	<b>Boccola / Bushing</b>	Ottone / Brass
<b>5</b>	<b>Molla / Spring</b>	Acciaio inossidabile / Stainless steel
<b>6</b>	<b>Guarnizione / Seal</b>	NBR

### Diagramma pressione temperatura / Pressure temperature diagram

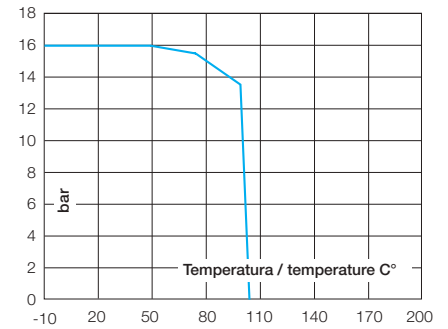

### Perdite di carico / Friction losses diagrams

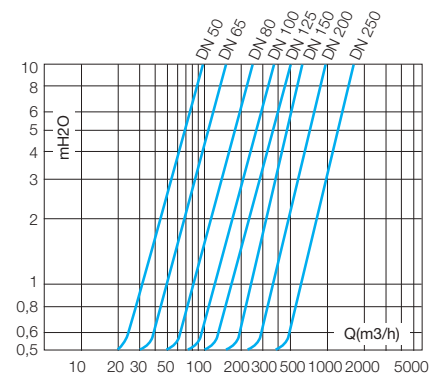

### Dimensioni e pesi / Dimensions and weights

Codice Code	Misura Size	DN	PN	Pressione apertura mbar Opening pressure mbar	Peso in kg. Weight in kg.	KV m³/h	Dimensioni in mm Dimensions in mm		
							Ø	B	C
H245009	2"	50	16	37.5 - 62.5	5,65	95	51	165	100
H245010	2" 1/2	65	16	31 - 63.5	7,85	140	63	185	120
H245011	3"	80	16	28 - 58	10,05	250	80	200	140
H245012	4"	100	16	32 - 61	13,25	355	100	220	170
H245013	5"	125	16	18 - 56	21,30	505	125	250	200
H245014	6"	150	16	17 - 51.5	29,15	640	150	285	230
H245016	8"	200	16	22 - 63	48,15	995	200	340	300
H245018	10"	250	16	21 - 68	82,00	1.750	250	405	370

M3

## N6VRFL

Valvole ritegno  
a palla in ghisa /  
Cast iron ball  
check valves

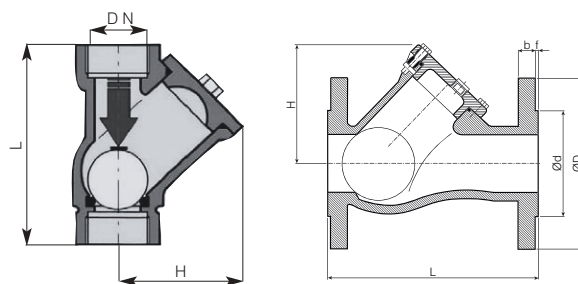

<b>Modello / Model</b> N6VRFL	<b>Materiale / Material</b> Ghisa / Cast iron	<b>Tenuta / Seal</b> NBR	<b>DN</b> 32 – 150	<b>PN</b> 10
----------------------------------	--	-----------------------------	-----------------------	-----------------

### Caratteristiche tecniche / Construction features

- **Connessioni filettate femmina secondo /**  
Threaded ends female according to  
UNI ISO 228/1
- **Connessioni flangiate con foratura  
secondo /** Flanged ends according to  
UNI EN 1092-2 PN 10/16
- **Pressione nominale di esercizio /**  
Nominal working pressure  
10 bar
- **Temperatura di esercizio /** Working pressure  
-10°C – +70°C
- **Applicazioni acque reflue, fluidi densi  
o carichi di elementi in sospensione /**  
Applications dense and loaded liquids
- **Installazione verticale e orizzontale /**  
Installation vertical and horizontal

### Componenti e materiali / Components and materials

<b>Corpo / Body</b>	Ghisa sferoidale GJS -400-15 / GJS -400-15 ductile iron
<b>Trattamento superficiale /</b> Surface treatment	Verniciatura epossidica / Epoxy coated
<b>Dadi e viti / Nuts and bolts</b>	Acciaio inox / SS Aisi 304
<b>Sfera / Ball</b>	Alluminio (ghisa per versione flangiata) con rivestimento in NBR / Aluminum (cast iron for flanged version) NBR rubber coated

### Dimensioni e pesi / Dimensions and weights

Codice Code	Versione Type	Misura Size	DN	PN	Peso in kg. Weight in kg.	KV m <sup>3</sup> /h	Dimensioni in mm Dimensions in mm						Flange Flanges		
							D	d	b	f	H	L	N. Fori N. holes	D. Fori D. holes	Interasse Interaxe
N6VRFL005	Filettata / Threaded	1" 1/4	32	10	2,1	29,4	-	-	-	-	80	140	-	-	-
N6VRFL010		1" 1/2	40	10	2,3	57,8	-	-	-	-	82	140	-	-	-
N6VRFL020		2"	50	10	3,1	78,3	-	-	-	-	90	180	-	-	-
N6VRFL030		2" 1/2	65	10	6,7	110,4	-	-	-	-	130	250	-	-	-
N6VRFL050	Flangiata / Flanged	2" 1/2	65	10	11,5	136	185	122	15	3	130	240	4	18	145
N6VRFL060		3"	80	10	15,5	267	200	134	18	3	150	260	8	18	160
N6VRFL070		4"	100	10	22,5	396	220	158	18	3	190	300	8	18	180
N6VRFL075		5"	125	10	33	671	250	184	18	3	215	350	8	18	210
N6VRFL080		6"	150	10	45,5	890	285	212	22	3	240	400	8	22	240

M3

# H0250

**Valvole di ritegno a clapet in ottone / Brass swing check valves**

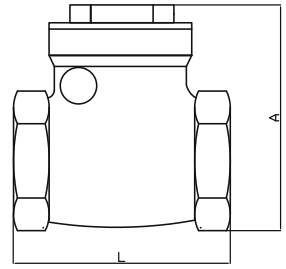
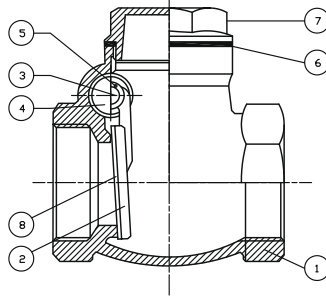

**Modello / Model**  
H0250

**Materiale / Material**  
Ottone / Brass

**Tenuta / Seal**  
NBR

**DN**  
15 - 100

**PN**  
8 - 12

## Caratteristiche tecniche / Construction features

- **Connessioni filettate gas femmina secondo** / Threaded ends female gas according to UNI ISO 228/1
- **Pressione nominale di esercizio** / Nominal working pressure  
12 bar (da/from 1/2" a/to 1")  
10 bar (da/from 1" 1/4 a/to 2")  
8 bar (da/from 2"1/2 a/to 4")
- **Temperatura di esercizio** / Working temperature  
-20°C - +100°C
- **Installazione orizzontale** / Installation horizontal

## Componenti e materiali / Components and materials

<b>1</b>	<b>Corpo</b> / Body	Ottone / Brass
<b>2</b>	<b>Otturatore</b> / Disc	Ottone / Brass
<b>3</b>	<b>Perno</b> / Stem	Ottone / Brass
<b>4</b>	<b>Tappo</b> / Plug	Ottone / Brass
<b>5</b>	<b>Tenuta</b> / Gasket	Fibra / Fiber
<b>6</b>	<b>Tenuta</b> / Gasket	Fibra / Fiber
<b>7</b>	<b>Coperchio</b> / Bonnet	Ottone / Brass
<b>8</b>	<b>Guarnizione</b> / Gasket	NBR

## Diagramma pressione temperatura / Pressure temperature diagram

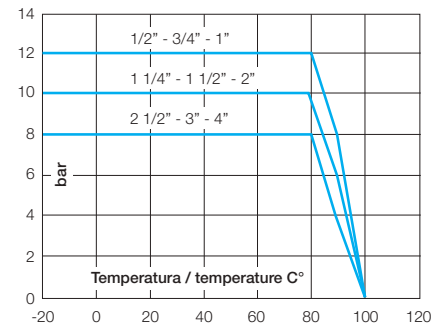

## Dimensioni e pesi / Dimensions and weights

Codice Code	Misura Size	DN	PN	Peso in gr. Weight in gr.	KV m³/h	Dimensioni in mm Dimensions in mm	
						L	A
H025002	1/2"	15	12	164	3,4	49	52
H025003	3/4"	20	12	221	8,9	58	63
H025004	1"	25	12	322	21	70	69
H025005	1" 1/4	32	10	458	32	80	87
H025006	1" 1/2	40	10	724	52	88	97
H025007	2"	50	10	1.010	83	102	110
H025008	2"1/2	65	8	1.476	217	115	110
H025009	3"	80	8	2.344	348	134	132
H025010	4"	100	8	3.792	525	163	163

## Perdite di carico / Friction losses diagrams

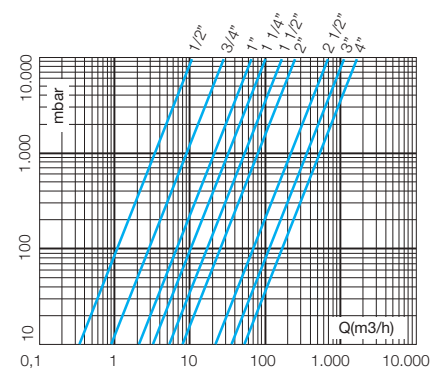







## Valvole di intercettazione

### Shut-off valves

- **Le valvole di intercettazione consentono di intercettare e interrompere il flusso di un fluido - acqua, gas o liquidi industriali - all'interno di un impianto idraulico. Sono caratterizzate da perfetta tenuta una volta chiuse e devono garantire la minima perdita di carico se completamente aperte.** / Shutoff valves intercept and interrupt the flow of a fluid - water, gas or industrial liquid - inside a hydraulic system. They are characterized by perfect sealing once closed and they must guarantee minimum friction losses if fully open.
- **Alcune tipologie di valvole di intercettazione possono essere utilizzate come valvole di regolazione del flusso e della pressione.** / Some types of shutoff valves can be used to regulate the flow and pressure
- **Le valvole di intercettazione, a seconda della forma costruttiva e dell'utilizzo a cui sono destinate, possono essere a farfalla, a sfera, a saracinesca, a globo, a spillo. Sono realizzate in acciaio inox Aisi 316, in acciaio al carbonio e in ottone.** / According to how they are made and used, shutoff valves can be butterfly, ball, gate, globe, needle. They are made of Aisi 316 stainless steel, carbon steel and brass.
- **Le pressioni di esercizio vanno da 16 a 200 bar e le temperature da -20 a +240 °C.** / They can be used where the working pressure ranges are from 16 to 200 bar and the temperatures from -20 to +240 °C.

M2

# H2048M

**Valvole a sfera a passaggio totale, 2 pezzi con bocchettone /**  
Full bore ball valves,  
2 pieces with union

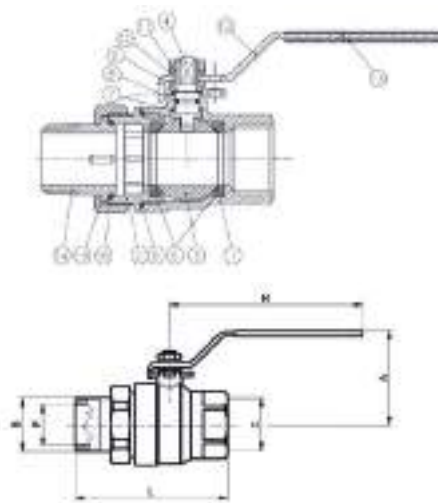

Modello / Model

**H2048M**

Materiale / Material

Aisi 316

Tenuta / Seal

PTFE + 15% FV / GF

DN

25 - 40

PN

63

## Caratteristiche tecniche /

### Construction features

- **Conessioni filettate secondo /** Threaded ends according to UNI EN 10226-1
- **Pressione nominale di esercizio /** Nominal working pressure 63 bar
- **Temperatura di esercizio /** Working temperature -25°C - +180°C
- **Albero anti-espulsione /** Blow-out proof stem
- **Valvole lucchettabili /** With locking system

## Diagramma pressione temperatura /

### Pressure temperature diagram

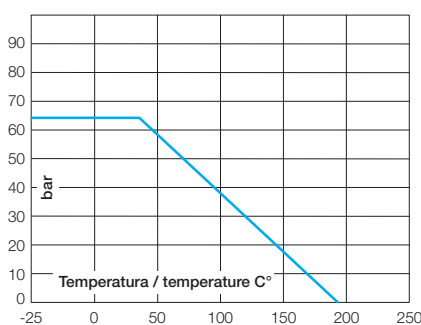

## Componenti e materiali /

### Components and materials

1	<b>Corpo /</b> Body	Acciaio inox / SS Aisi 316
2	<b>Tappo /</b> Cap	Acciaio inox / SS Aisi 316
3	<b>Sfera /</b> Ball	Acciaio inox / SS Aisi 316
4	<b>Albero /</b> Stem	Acciaio inox / SS Aisi 316
5	<b>Tenuta sfera /</b> Seat ball	PTFE + 15% fibra di vetro / PTFE + 15% glass fiber
6	<b>Guarnizione /</b> Gasket	PTFE
7	<b>Rondella /</b> Trust Washer	PTFE
8	<b>Anello OR /</b> O-ring	FPM
9	<b>Anello premistoppa /</b> Stem packing	Acciaio inox / SS Aisi 304
10	<b>Rondella /</b> Washer	Acciaio inox / SS Aisi 304
11	<b>Dado /</b> Nut	Acciaio inox / SS Aisi 304
12	<b>Maniglia /</b> Handle	Acciaio inox / SS Aisi 304
13	<b>Coprimaniglia /</b> Handle Sleeve	Vinile / Vynil
14	<b>Raccordo maschio /</b> Nipple	Acciaio inox / SS Aisi 316
15	<b>Controdado /</b> Nut	Acciaio inox / SS Aisi 316
16	<b>Guarnizione /</b> O-ring	NBR

## Dimensioni e pesi /

### Dimensions and weights

Codice Code	Misura Size	DN	PN	Peso in kg. Weight in kg.	KV m³/h	Dimensioni in mm Dimensions in mm					
						A	L	M	P	C	B
H2048M06	1"	25	63	0,76	83	62	110	122	25	1" F	1" M
H2048M07	1" 1/4	32	63	1,34	130	80	125	180	32	1" 1/4 F	1" 1/4 M
H2048M08	1" 1/2	40	63	1,84	205	85	136	180	40	1" 1/2 F	1" 1/2 M

M2

# H2013-BV6240

**Valvole a sfera a  
passaggio totale,  
2 pezzi / Full bore ball  
valves, 2 pieces**

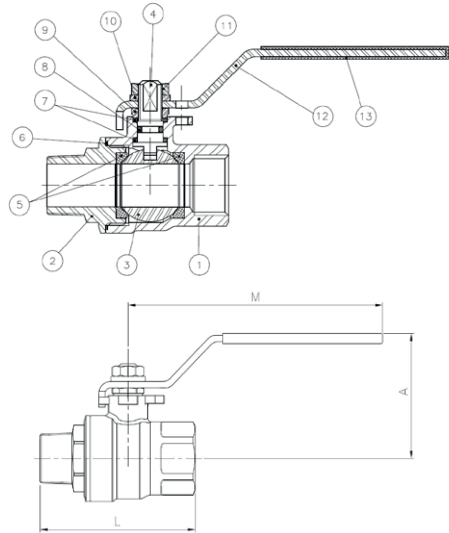

**Modello / Model**  
**H2013-BV6240**

**Materiale / Material**  
Aisi 316

**Tenuta / Seal**  
PTFE + 15% FV / GF

**DN**  
8 – 50

**PN**  
63

## Caratteristiche tecniche / Construction features

- **Connessioni filettate secondo** / Threaded ends according to UNI EN 10226-1
- **Pressione nominale di esercizio** / Nominal working pressure 63 bar
- **Temperatura di esercizio** / Working temperature -25°C – +180°C
- **Albero anti-espulsione** / Blow-out proof stem
- **Valvole lucchettabili** / With locking system

## Diagramma pressione temperatura / Pressure temperature diagram

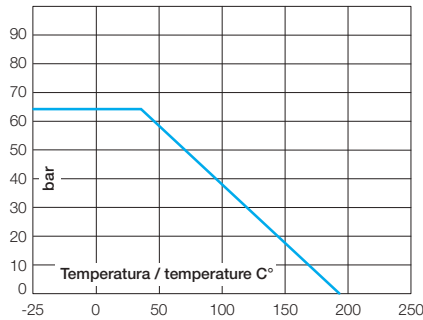

## Componenti e materiali / Components and materials

<b>1</b>	<b>Corpo</b> / Body	Acciaio inox / SS Aisi 316
<b>2</b>	<b>Tappo</b> / Cap	Acciaio inox / SS Aisi 316
<b>3</b>	<b>Sfera</b> / Ball	Acciaio inox / SS Aisi 316
<b>4</b>	<b>Albero</b> / Stem	Acciaio inox / SS Aisi 316
<b>5</b>	<b>Tenuta sfera / Seat ball</b>	PTFE + 15% fibra di vetro / PTFE + 15% glass fiber
<b>6</b>	<b>Guarnizione / Gasket</b>	PTFE
<b>7</b>	<b>Rondella / Trust Washer</b>	PTFE
<b>8</b>	<b>Anello OR albero / O' ring stem</b>	FPM
<b>9</b>	<b>Anello premistoppa / Stem packing</b>	Acciaio inox / SS Aisi 304
<b>10</b>	<b>Rondella / Washer</b>	Acciaio inox / SS Aisi 304
<b>11</b>	<b>Dado / Nut</b>	Acciaio inox / SS Aisi 304
<b>12</b>	<b>Maniglia / Handle</b>	Acciaio inox / SS Aisi 304
<b>13</b>	<b>Coprimaniglia / Handle Sleeve</b>	Vinile / Vynil

## Dimensioni e pesi / Dimensions and weights

Codice Code	Misura Size	DN	PN	Peso in gr. Weight in gr.	KV m³/h	Dimensioni in mm Dimensions in mm		
						A	L	M
H201302	1/4"	8	63	210	6	50	56	104
H201303	3/8"	10	63	200	10	50	56	104
H201304	1/2"	15	63	240	24	51,5	63	104
H201305	3/4"	20	63	501	43	62	79	122
H201306	1"	25	63	672	83	65	90	122
BV6240M07	1" 1/4	32	63	1.080	130	79	100	156
BV6240M08	1" 1/2	40	63	1.395	205	83	112	156
BV6240M09	2"	50	63	2.545	340	99	142	194

M2

## GLOBE / 2P

**Valvole a sfera 2 pezzi a passaggio totale /**  
2 pieces full bore ball valves



Versione standard /  
Standard type



Versione Camlock /  
Camlock type

**Modello / Model**  
**GLOBE 2P**

**Materiale / Material**  
Aisi 316

**Tenuta / Seal**  
PTFE + 15% FV / GF

**DN**  
8 – 80

**PN**  
10 – 63

### Caratteristiche tecniche / Construction features

- **Connessioni filettate femmina secondo /**  
Threaded ends according to  
UNI EN 10226-1, NPT
- **Pressione nominale di esercizio / Nominal**  
working pressure  
63 bar (10 bar Camlock)
- **Temperatura di esercizio / Working**  
temperature  
-25°C – +180°C
- **Albero anti-espulsione / Blow-out proof stem**
- **Valvole lucchettabili / With locking system**

### Diagramma pressione temperatura / Pressure temperature diagram

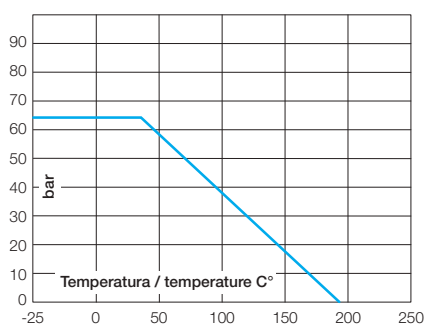

### Componenti e materiali / Components and materials

<b>1</b>	<b>Corpo / Body</b>	Acciaio inox / SS Aisi 316
<b>2</b>	<b>Tappo / Cap</b>	Acciaio inox / SS Aisi 316
<b>3</b>	<b>Sfera / Ball</b>	Acciaio inox / SS Aisi 316
<b>4</b>	<b>Albero / Stem</b>	Acciaio inox / SS Aisi 316
<b>5</b>	<b>Tenuta sfera / Seat ball</b>	PTFE + 15% fibra di vetro / PTFE + 15% glass fiber
<b>6</b>	<b>Guarnizione / Gasket</b>	PTFE
<b>7</b>	<b>Rondella / Trust Washer</b>	PTFE
<b>8</b>	<b>Anello OR albero / O' ring stem</b>	FPM
<b>9</b>	<b>Anello premistoppa / Stem packing</b>	Acciaio inox / SS Aisi 304
<b>10</b>	<b>Rondella / Washer</b>	Acciaio inox / SS Aisi 304
<b>11</b>	<b>Dado / Nut</b>	Acciaio inox / SS Aisi 304
<b>12</b>	<b>Maniglia / Handle</b>	Acciaio inox / SS Aisi 304
<b>13</b>	<b>Coprimaniglia / Handle Sleeve</b>	Vinile / Vynil

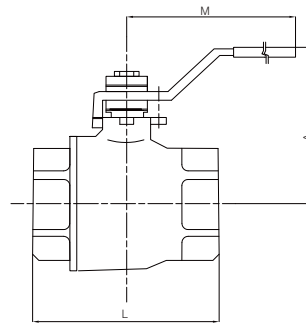
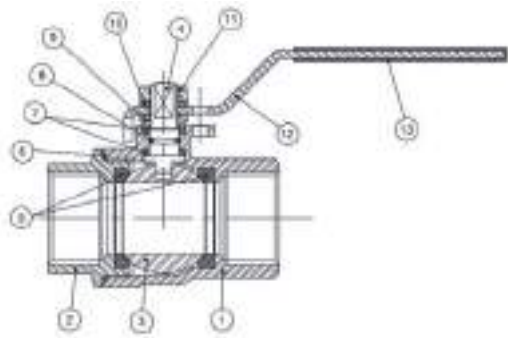

### Dimensioni e pesi / Dimensions and weights

Codice Code	Versione Type	Misura Size	DN	PN	Peso in kg. Weight in kg.	KV m <sup>3</sup> /h	Dimensioni in mm Dimensions in mm		
							A	L	M
900950	Standard	1/4"	8	63	0,207	6	50	50	104
900951		3/8"	10	63	0,195	10	50	50	104
900952		1/2"	15	63	0,237	24	51,5	55	104
900953		3/4"	20	63	0,442	43	62	70	122
900954		1"	25	63	0,606	83	65	83	122
900955		1" 1/4	32	63	1,084	130	82	91	180
900956		1" 1/2	40	63	1,544	205	88	103	180
900957		2"	50	63	2,648	340	106	120	219
900958		2" 1/2	65	63	4,707	520	119	152	230
900959	3"	80	63	7,288	1.100	135	172	275	
900950NPT	NPT	1/4"	8	63	0,207	6	50	50	104
900951NPT		3/8"	10	63	0,195	10	50	50	104
900952NPT		1/2"	15	63	0,237	24	51,5	55	104
900953NPT		3/4"	20	63	0,442	43	62	70	122
900954NPT		1"	25	63	0,606	83	65	83	122
900955NPT		1" 1/4	32	63	1,084	130	82	91	180
900956NPT		1" 1/2	40	63	1,544	205	88	103	180
900957NPT		2"	50	63	2,648	340	106	120	219
900958NPT		2" 1/2	65	63	4,707	520	119	152	230
900959NPT	3"	80	63	7,288	1.100	135	172	275	
900952CMLK	Camlock	1/2"	15	10	0,29	17	51,5	82	104
900953CMLK		3/4"	20	10	0,54	26	62	96	122
900954CMLK		1"	25	10	0,75	42	65	116	122
900955CMLK		1" 1/4	32	10	1,37	69	82	131	180
900956CMLK		1" 1/2	40	10	1,85	113	88	141	180
900957CMLK		2"	50	10	3,20	190	106	164	219
900958CMLK		2" 1/2	65	10	5,41	305	119	202	230
900959CMLK	3"	80	10	8,30	530	135	223	275	

M2

## GLOBE / 3P

Valvole a sfera a  
passaggio totale,  
3 pezzi / Full bore ball  
valves, 3 pieces

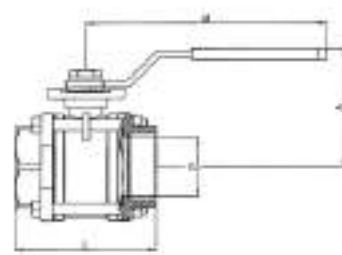
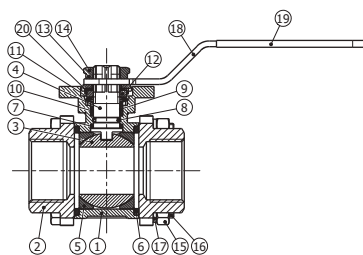

Modello / Model  
**GLOBE 3P**

Materiale / Material  
Aisi 316

Tenuta / Seal  
PTFE + 15% FV / GF

DN  
8 – 100

PN  
63

### Caratteristiche tecniche / Construction features

- **Montaggio diretto attuatore secondo /**  
Direct actuator installation according to  
ISO 5211
- **Connessioni filettate femmina secondo /**  
Threaded ends female according to  
UNI EN 10226-1, NPT
- **Attacchi a saldare /** Welding ends  
BUTT-WELD: ANSI B 16.25,  
SOCKET-WELD: ANSI B 16.11
- **Pressione nominale di esercizio /** Nominal  
working pressure  
63 bar
- **Temperatura di esercizio /**  
Working temperature  
-25°C – +180°C
- **Albero anti-espulsione /** Blow-out proof  
stem

### Diagramma pressione temperatura / Pressure temperature diagram

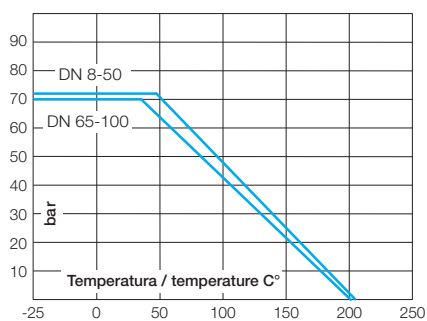

### Componenti e materiali / Components and materials

1	<b>Corpo</b> / Body	Acciaio inox / SS Aisi 316
2	<b>Tappo</b> / Cap	Acciaio inox / SS Aisi 316
3*	<b>Sfera</b> / Ball	Acciaio inox / SS Aisi 316
4*	<b>Albero</b> / Stem	Acciaio inox / SS Aisi 316
5*	<b>Tenuta sfera</b> / Seat ball	PTFE + 15% fibra di vetro / PTFE + 15% glass fiber
6*	<b>Guarnizione</b> / Gasket	PTFE + 15% grafite / PTFE + 15% graphite
7*	<b>Rondella</b> / Trust Washer	PTFE + 15% grafite / PTFE + 15% graphite
8*	<b>Anello OR albero</b> / Stem O-ring	FPM
9*	<b>Pacco albero</b> / Stem packing	PTFE
10	<b>Anello albero</b> / Stem ring	Acciaio inox / SS Aisi 304
11	<b>Rondella</b> / Washer	Acciaio inox / SS 301
12	<b>Dado - Arresto</b> / Nut - Stopper	Acciaio inox / SS Aisi 304
13	<b>Rondella</b> / Washer	Acciaio inox / SS Aisi 304
15	<b>Bullone - Dado</b> / Bolt - Nut	Acciaio inox / SS Aisi 304
16		
18	<b>Maniglia</b> / Handle	Acciaio inox / SS Aisi 304
19	<b>Coprimaniglia</b> / Handle Sleeve	Vinile / Vynil
20	<b>Antisvitamento</b> / Lock washer	Acciaio inox / SS Aisi 304

\* **Ricambi disponibili** / Spare parts

Su richiesta /  
On request

Con foro sfera a V di  
30° - 60° - 90° /  
With V ball hole of  
30° - 60° - 90°



**Dimensioni e pesi /**  
Dimensions and weights

Codice Code	Versione Type	Misura Size	DN	PN	Peso in gr. Weight in gr.	KV m <sup>3</sup> /h	Dimensioni in mm Dimensions in mm					
							A	L	M	P	ISO 5211	
900978	Standard	1/4"	8	63	390	6	60	47,6	112	11	F-03	
900979		3/8"	10	63	380	10	60	47,6	112	12,7	F-03	
900980		1/2"	15	63	440	24	60	56	112	15	F-03/F-04	
900981		3/4"	20	63	820	43	70	73	138	20	F-04/F-05	
900982		1"	25	63	1.020	83	70	82	138	25	F-04/F-05	
900983		1" 1/4	32	63	1.790	130	88	91	160	32	F-05/F-07	
900984		1" 1/2	40	63	2.460	205	94	104	205	40	F-05/F-07	
900985		2"	50	63	3.470	340	100	120	205	50	F-05/F-07	
900986		2" 1/2	65	63	8.500	520	150	155	330	65	F-07/F-10	
900987		3"	80	63	12.400	1.100	165	182	330	80	F-07/F-10	
900988		4"	100	63	19.650	1.820	175	220	340	100	F-07/F-10	
H2025N02		NPT	1/4"	8	63	390	6	60	47,6	112	11	F-03
H2025N03			3/8"	10	63	380	10	60	47,6	112	12,7	F-03
H2025N04	1/2"		15	63	440	24	60	56	112	15	F-03/F-04	
H2025N05	3/4"		20	63	820	43	70	73	138	20	F-04/F-05	
H2025N06	1"		25	63	1.020	83	70	82	138	25	F-04/F-05	
H2025N07	1" 1/4		32	63	1.790	130	88	91	160	32	F-05/F-07	
H2025N08	1" 1/2		40	63	2.460	205	94	104	205	40	F-05/F-07	
H2025N09	2"		50	63	3.470	340	100	120	205	50	F-05/F-07	
H2025N10	2" 1/2		65	63	8.500	520	150	155	330	65	F-07/F-10	
H2025N11	3"		80	63	12.400	1.100	165	182	330	80	F-07/F-10	
H2025N12	4"		100	63	19.650	1.820	175	220	340	100	F-07/F-10	
H202602	BUTT WELD		1/4"	8	63	370	6	60	47,6	112	11	F-03
H202603		3/8"	10	63	370	10	60	47,6	112	12,7	F-03	
H202604		1/2"	15	63	440	24	60	55	112	15	F-03/F-04	
H202605		3/4"	20	63	810	43	70	73	138	20	F-04/F-05	
H202606		1"	25	63	990	83	70	81	138	25	F-04/F-05	
H202607		1" 1/4	32	63	1.770	130	88	91	160	32	F-05/F-07	
H202608		1" 1/2	40	63	2.350	205	94	103	205	40	F-05/F-07	
H202609		2"	50	63	3.280	340	100	120	205	50	F-05/F-07	
H202610		2" 1/2	65	63	8.550	520	150	155	330	65	F-07/F-10	
H202611		3"	80	63	11.850	1.100	165	182	330	80	F-07/F-10	
H202612		4"	100	63	20.300	1.820	175	229	340	100	F-07/F-10	
H202702		SOCKET WELD	1/4"	8	63	380	6	60	47,6	112	11	F-03
H202703	3/8"		10	63	380	10	60	47,6	112	12,7	F-03	
H202704	1/2"		15	63	440	24	60	55	112	15	F-03/F-04	
H202705	3/4"		20	63	820	43	70	73	138	20	F-04/F-05	
H202706	1"		25	63	1.020	83	70	81	138	25	F-04/F-05	
H202707	1" 1/4		32	63	1.780	130	88	91	160	32	F-05/F-07	
H202708	1" 1/2		40	63	2.470	205	94	103	205	40	F-05/F-07	
H202709	2"		50	63	3.400	340	100	120	205	50	F-05/F-07	
H202710	2" 1/2		65	63	8.800	520	150	155	330	65	F-07/F-10	
H202711	3"		80	63	12.350	1.100	165	182	330	80	F-07/F-10	
H202712	4"		100	63	19.600	1.820	175	229	340	100	F-07/F-10	

M2

## H2015

**Valvole a sfera a 2 pezzi con montaggio diretto attuatore /**  
**2 pieces ball valves with direct actuator installation**

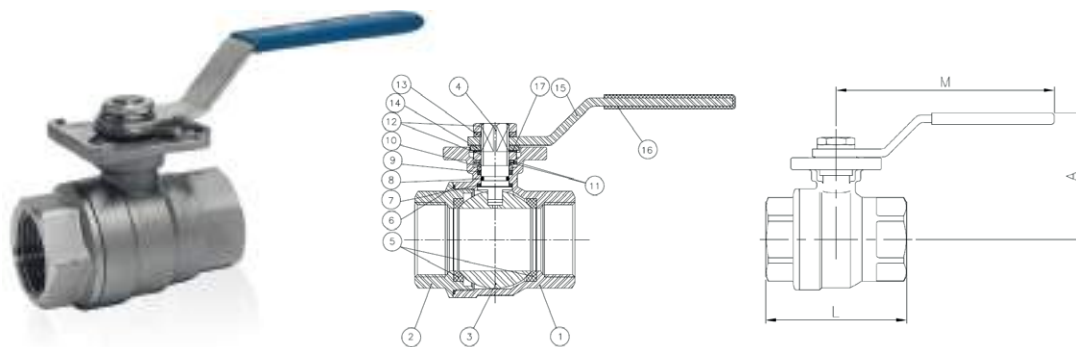

**Modello / Model**  
**H2015**

**Materiale / Material**  
 Aisi 316

**Tenuta / Seal**  
 PTFE + 15% FV / GF

**DN**  
 8 – 50

**PN**  
 63

**Caratteristiche tecniche /**  
**Construction features**

- **Montaggio diretto attuatore secondo /**  
Direct actuator installation according to ISO 5211
- **Connessioni filettate femmina secondo /**  
Threaded ends female according to UNI EN 10226-1
- **Pressione nominale di esercizio / Nominal working pressure**  
63 bar
- **Temperatura di esercizio / Working temperature**  
-25°C – +180°C
- **Albero anti-espulsione / Blow-out proof stem**
- **Valvole lucchettabili / With locking system**

**Diagramma pressione temperatura /**  
**Pressure temperature diagram**

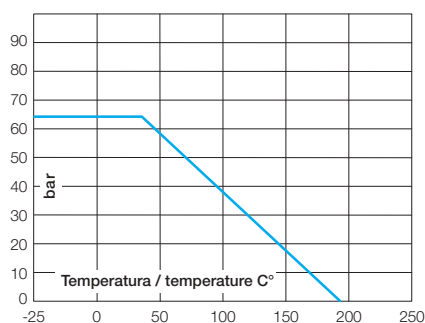

**Componenti e materiali /**  
**Components and materials**

1	<b>Corpo / Body</b>	Acciaio inox / SS Aisi 316
2	<b>Tappo / Cap</b>	Acciaio inox / SS Aisi 316
3*	<b>Sfera / Ball</b>	Acciaio inox / SS Aisi 316
4*	<b>Albero / Stem</b>	Acciaio inox / SS Aisi 316
5*	<b>Tenuta sfera / Seat ball</b>	PTFE + 15% fibra di vetro / PTFE + 15% glass fiber
6*	<b>Guarnizione / Gasket</b>	PTFE
7*	<b>Rondella / Trust Washer</b>	PTFE + grafite / PTFE + graphite
8*	<b>Anello OR / Stem O-ring</b>	FPM
9*	<b>Pacco albero / Stem packing</b>	PTFE
10	<b>Anello albero / Stem ring</b>	Acciaio inox / SS Aisi 304
11	<b>Rondella / Washer</b>	Acciaio inox / SS 301
12	<b>Dado / Nut</b>	Acciaio inox / SS Aisi 304
13	<b>Rondella / Washer</b>	Acciaio inox / SS Aisi 304
14	<b>Fine corsa / Stopper</b>	Acciaio inox / SS Aisi 304
15	<b>Maniglia / Handle</b>	Acciaio inox / SS Aisi 304
16	<b>Coprimaniglia / Handle Sleeve</b>	Vinile / Vynil
17	<b>Antisvitamento / Lockwasher</b>	Acciaio inox / SS Aisi 304

\* **Ricambi disponibili / Spare parts**

**Dimensioni e pesi /**  
**Dimensions and weights**

Codice Code	Misura Size	DN	PN	Peso in kg. Weight in kg.	KV m³/h	Dimensioni in mm Dimensions in mm			
						A	L	M	ISO 5211
H201502	1/4"	8	63	0,30	6	62	50	112	F-03
H201503	3/8"	10	63	0,30	10	62	50	112	F-03
H201504	1/2"	15	63	0,35	24	63	55	112	F-03/F-04
H201505	3/4"	20	63	0,56	43	70	70,5	138	F-04/F-05
H201506	1"	25	63	0,78	83	70	83	160	F-04/F-05
H201507	1" 1/4	32	63	1,35	130	88	91	160	F-05/F-07
H201508	1" 1/2	40	63	1,90	205	94	103	205	F-05/F-07
H201509	2"	50	63	2,83	340	100	120	205	F-05/F-07

**Su richiesta /**  
**On request**

**Con foro sfera a V di**  
**30° - 60° - 90° /**  
 With V ball hole of  
 30° - 60° - 90°





M2

# H2009

**Valvole a sfera a 2 pezzi a passaggio totale con maniglia a farfalla / Full bore ball valves 2 pieces with butterfly handle**

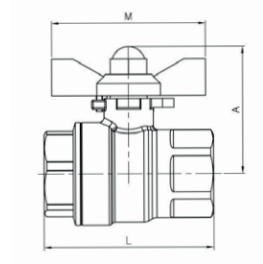
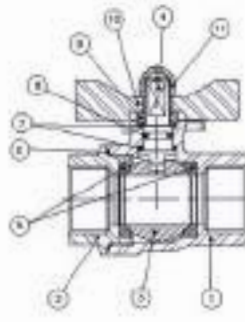

**Modello / Model**  
H2009

**Materiale / Material**  
Aisi 316

**Tenuta / Seal**  
PTFE + 15% FV / GF

**DN**  
8 – 25

**PN**  
63

## Caratteristiche tecniche / Construction features

- **Connessioni filettate secondo** / Threaded ends according to UNI EN 10226-1
- **Pressione nominale di esercizio** / Nominal working pressure 63 bar
- **Temperatura di esercizio** / Working temperature -25°C – +180°C
- **Albero anti-espulsione** / Blow-out proof stem

## Diagramma pressione temperatura / Pressure temperature diagram

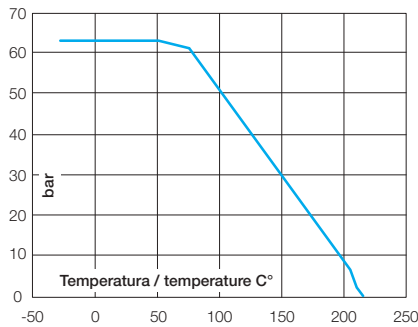

## Componenti e materiali / Components and materials

<b>1</b>	<b>Corpo</b> / Body	Acciaio inox / SS 1.4408
<b>2</b>	<b>Coperchio</b> / Cap	Acciaio inox / SS 1.4408
<b>3</b>	<b>Sfera</b> / Ball	Acciaio inox / SS 1.4408
<b>4</b>	<b>Albero</b> / Stem	Acciaio inox / SS Aisi 316
<b>5</b>	<b>Tenuta sfera</b> / Ball Seat	PTFE + 15% F.V. / G.F.
<b>6</b>	<b>Guarnizione</b> / Gasket	PTFE
<b>7</b>	<b>Rondella</b> / Trust Washer	PTFE
<b>8</b>	<b>Anello OR</b> / O-ring	FPM
<b>9</b>	<b>Pacco albero</b> / Stem packing	Acciaio inox / SS Aisi 304
<b>10</b>	<b>Maniglia a farfalla</b> / Butterfly Handle	Acciaio inox / SS Aisi 304
<b>11</b>	<b>Dado</b> / Nut	Acciaio inox / SS Aisi 304

## Dimensioni e pesi / Dimensions and weights

Codice Code	Misura Size	DN	PN	Peso in gr. Weight in gr.	KV m³/h	Dimensioni in mm Dimensions in mm		
						A	L	M
H200902	1/4"	8	63	192	6	38	50	50
H200903	3/8"	10	63	180	10	38	50	50
H200904	1/2"	15	63	222	24	41	55	50
H200905	3/4"	20	63	410	43	58	70	63
H200906	1"	25	63	565	83	61	83	63

M2

# H2010

**Valvole a sfera a 2 pezzi a passaggio totale con maniglia a farfalla / Full bore ball valves 2 pieces with butterfly handle**

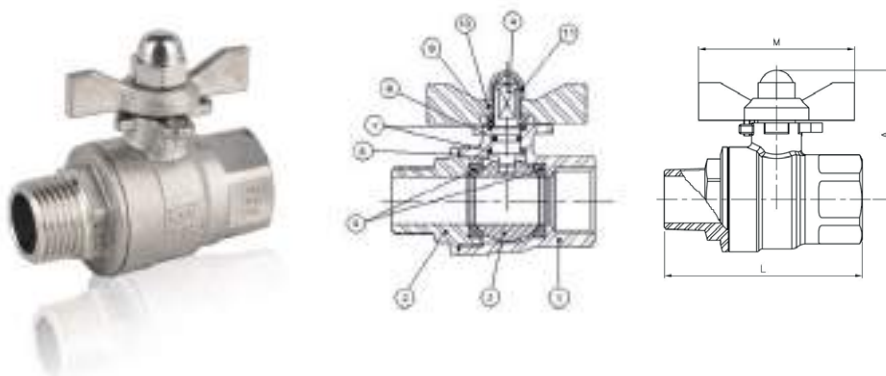

**Modello / Model**  
H2010

**Materiale / Material**  
Aisi 316

**Tenuta / Seal**  
PTFE + 15% FV / GF

**DN**  
8 – 25

**PN**  
63

## Caratteristiche tecniche / Construction features

- **Connessioni filettate secondo / Threaded ends according to** UNI EN 10226-1
- **Pressione nominale di esercizio / Nominal working pressure** 63 bar
- **Temperatura di esercizio / Working temperature** -25°C – +180°C
- **Albero anti-espulsione / Blow-out proof stem**

## Diagramma pressione temperatura / Pressure temperature diagram

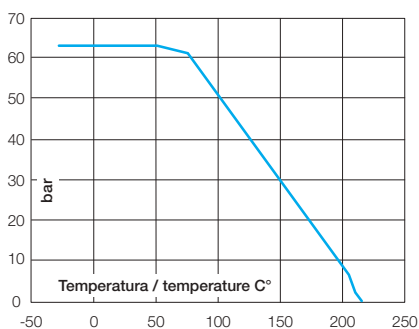

## Componenti e materiali / Components and materials

<b>1</b>	<b>Corpo / Body</b>	Acciaio inox / SS 1.4408
<b>2</b>	<b>Coperchio / Cap</b>	Acciaio inox / SS 1.4408
<b>3</b>	<b>Sfera / Ball</b>	Acciaio inox / SS 1.4408
<b>4</b>	<b>Albero / Stem</b>	Acciaio inox / SS Aisi 316
<b>5</b>	<b>Tenuta sfera / Ball Seat</b>	PTFE + 15% F.V. / G.F.
<b>6</b>	<b>Guarnizione / Gasket</b>	PTFE
<b>7</b>	<b>Rondella / Trust Washer</b>	PTFE
<b>8</b>	<b>Anello OR / O-ring</b>	FPM
<b>9</b>	<b>Pacco albero / Stem packing</b>	Acciaio inox / SS Aisi 304
<b>10</b>	<b>Maniglia a farfalla / Butterfly Handle</b>	Acciaio inox / SS Aisi 304
<b>11</b>	<b>Dado / Nut</b>	Acciaio inox / SS Aisi 304

## Dimensioni e pesi / Dimensions and weights

Codice Code	Misura Size	DN	PN	Peso in gr. Weight in gr.	KV m³/h	Dimensioni in mm Dimensions in mm		
						A	L	M
H201002	1/4"	8	63	200	6	32	56	50
H201003	3/8"	10	63	183	10	32	56	50
H201004	1/2"	15	63	224	24	41	63	50
H201005	3/4"	20	63	464	43	58	79	63
H201006	1"	25	63	635	83	61	90	63

M2

# MINIGLOBE

**Valvole a sfera monoblocco a passaggio ridotto** / One piece reduced bore ball valves

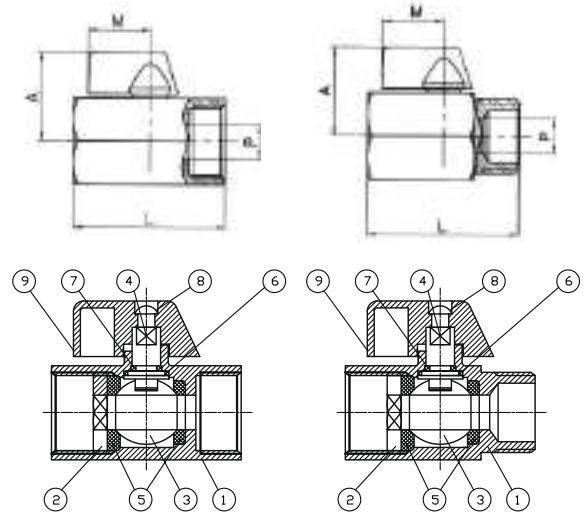

**Modello / Model**  
**MINIGLOBE**

**Materiale / Material**  
Aisi 316

**Tenuta / Seal**  
PTFE

**DN**  
8 – 25

**PN**  
63

## Caratteristiche tecniche / Construction features

- **Connessioni filettate secondo** / Threaded ends according to UNI EN 10226-1
- **Pressione nominale di esercizio** / Nominal working pressure 63 bar
- **Temperatura di esercizio** / Working temperature -25°C – +180°C

## Diagramma pressione temperatura / Pressure temperature diagram

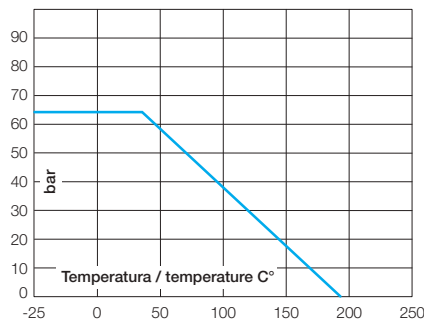

## Componenti e materiali / Components and materials

<b>1</b>	<b>Corpo</b> / Body	Acciaio inox Aisi 316 lucidato / SS Aisi 316 polished
<b>2</b>	<b>Coperchio</b> / Cap	Acciaio inox Aisi 316 lucidato / SS Aisi 316 polished
<b>3</b>	<b>Sfera</b> / Ball	Acciaio inox / SS Aisi 316
<b>4</b>	<b>Albero</b> / Stem	Acciaio inox / SS Aisi 304
<b>5</b>	<b>Tenuta sfera</b> / Seat ball	PTFE
<b>6</b>	<b>Anello di frizione</b> / Friction ring	PTFE
<b>7</b>	<b>Guarnizione</b> / O-ring	FPM
<b>8</b>	<b>Vite</b> / Screw	Acciaio inox / SS Aisi 304
<b>9</b>	<b>Maniglia</b> / Handle	Alluminio verniciato / Painted aluminum

## Dimensioni e pesi / Dimensions and weights

Codice Code	Versione Type	Misura Size	DN	PN	Peso in gr. Weight in gr.	KV m³/h	Dimensioni in mm Dimensions in mm			
							A	L	M	P
H200602	Femmina - femmina / Female - female	1/4"	8	63	104	3,5	26	42	22	8
H200603		3/8"	10	63	92	4	26	42	22	8
H200604		1/2"	15	63	125	5	28	46	22	9
H200605		3/4"	20	63	211	13	34	54	22	12,5
H200606		1"	25	63	300	28	34	65	22	15
H200502		Maschio - femmina / Male - female	1/4"	8	63	83	3,5	26	42	22
H200503	3/8"		10	63	82	4	26	42	22	8
H200504	1/2"		15	63	116	5	28	46	22	9
H200505	3/4"		20	63	193	13	34	54	22	12,5
H200506	1"		25	63	280	28	34	65	22	15

M3

## H2528

**Valvola a sfera flangiata** / Flanged ball valve

**Valvola a passaggio totale con base attuatore** / Full bore valve with integrated base for actuator

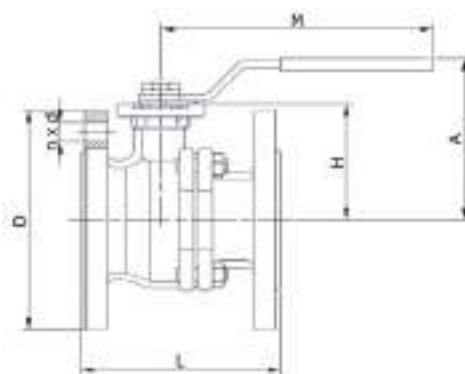

**Modello / Model**  
H2528

**Materiale / Material**  
Aisi 316

**Tenuta / Seal**  
PTFE + 15% FV/GF

**DN**  
15 – 200

**PN**  
16 – 40

### Caratteristiche tecniche / Construction features

- **Montaggio diretto attuatore** / Direct actuator installation
- **Scartamento tra le facce** / Face to face according to EN 558-S.27
- **Attacco flangiato secondo** / Flange end according to EN 1092-1
- **Temperatura di esercizio** / Working temperature -30°C – +180°C
- **Dispositivo antistatico** / Anti-static device
- **Certificazione** / Certification ATEX II 2 GD c T6 - T3/125 °C

### Diagramma pressione temperatura / Pressure temperature diagram

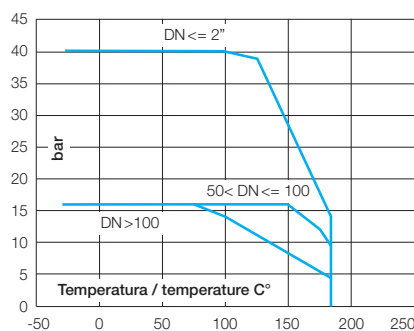

### Dimensioni e pesi / Dimensions and weights

Codice Code	DN	PN	Peso in kg. Weight in kg.	Dimensioni in mm Dimensions in mm								
				D	A	L	M	n x d	ISO 5211	H	h	C x C
H252804	15	40	2,2	95	85	115	170	4 x 14	F04	46	9,5	9 x 9
H252805	20	40	3,05	105	85	120	170	4 x 14	F04/F05	51	10	9 x 9
H252806	25	40	3,75	116	95	125	170	4 x 14	F04/F05	57	11	11 x 11
H252807	32	40	5,75	140	106	130	200	4 x 18	F05/F07	71	15,5	14 x 14
H252808	40	40	7	150	110	140	200	4 x 18	F05/F07	76	15,5	14 x 14
H252809	50	40	9,5	165	118	150	200	4 x 18	F05/F07	83	15,5	14 x 14
H252810	65	16	14,75	185	170	170	380	4 x 18	F07/F10	119	21	17 x 17
H252811	80	16	18,85	200	170	180	380	8 x 18	F07/F10	130	21	17 x 17
H252812	100	16	26,25	220	170	190	380	8 x 18	F07/F10	145	21	17 x 17
H252813	125	16	38	250	200	325	520	8 x 18	F10/F12	163	34	27 x 27
H252814	150	16	51	285	220	350	620	8 x 22	F10/F12	180	34	27 x 27
H252816	200	16	119	340	334	400	800	12 x 22	F12	253	27	27 x 27

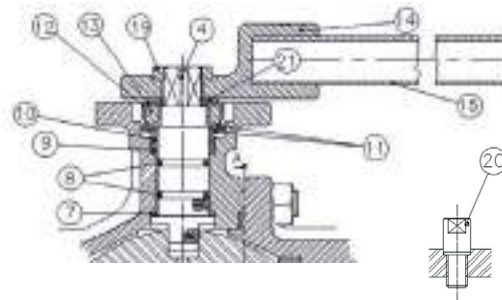
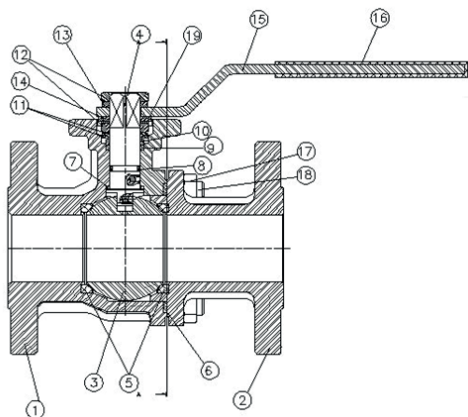

### Componenti e materiali / Components and materials

<b>1</b>	<b>Corpo / Body</b>	Acciaio inox / SS 1.4408			
	<b>Trattamento superficiale / Surface treatment</b>	Granigliatura / Shot blasting			
<b>2</b>	<b>Semicorpo chiusura / Cap</b>	Acciaio inox / SS 1.4408			
	<b>Trattamento superficiale / Surface treatment</b>	Granigliatura / Shot blasting			
<b>3*</b>	<b>Sfera / Ball</b>	Acciaio inox / SS 1.4408			
	<b>Trattamento superficiale / Surface treatment</b>	Lucidatura / Polishing			
<b>4*</b>	<b>Asse / Stem</b>	Acciaio inox / SS Aisi 316			
<b>5*</b>	<b>Tenuta / Ball Seat</b>	PTFE + 15% FV/GF			
<b>6*</b>	<b>Guarnizione / Gasket</b>	PTFE (fino a / until DN25) / SS + Graphite (da / from DN32)			
<b>7*</b>	<b>A. frizione / Thrust Washer</b>	PTFE + grafite / graphite			
<b>8*</b>	<b>Anello OR / O-ring</b>	FPM			
<b>9*</b>	<b>Pacco albero / Stem packing</b>	PTFE			
<b>10</b>	<b>Anello premi stoppa / Gland</b>	Acciaio inox / SS Aisi 304			
<b>11</b>	<b>Rondella / Spring Washer</b>	Acciaio inox / SS Aisi 301			
<b>12</b>	<b>Controdado / Nut</b>	Acciaio inox / SS Aisi 304			
			<b>13</b>	<b>Rondella / Washer</b>	Acciaio inox / SS Aisi 304
			<b>14</b>	<b>Fermo / Stopper</b>	Acciaio inox / SS Aisi 304
			<b>15</b>	<b>Maniglia / Handle</b>	Acciaio inox / SS Aisi 304
			<b>16</b>	<b>Coprimaniglia / Handle Sleeve</b>	Vinile / Vynil
			<b>17</b>	<b>Dado / Nut</b>	Acciaio inox / SS Aisi 304
			<b>18</b>	<b>Vite / Stud Bolt</b>	Acciaio inox / SS Aisi 304
			<b>19</b>	<b>Antirotazione / Lock Washer</b>	Acciaio inox / SS Aisi 304
			<b>14**</b>	<b>Corpo maniglia / Body Handle</b>	1.4408
				<b>Trattamento superficiale / Surface treatment</b>	Granigliatura / Shot blasting
			<b>19**</b>	<b>Controdado / Nut</b>	Acciaio inox / SS Aisi 304
			<b>20**</b>	<b>Fermo / Stopper</b>	Acciaio inox / SS Aisi 304
			<b>21**</b>	<b>Antirotazione / Lock Washer</b>	Acciaio inox / SS Aisi 304

\* **Ricambi disponibili / Spare parts**

\*\* **Solo per misure da / only for sizes**  
2"1/2 - 3" - 4" - 5" - 6" - 8"

### Su richiesta / On request

Con foro sfera a V di  
30° - 60° - 90° /  
With V ball hole of  
30° - 60° - 90°



M2

# BV6205M

**Valvole a sfera a 2 pezzi femmina-femmina a passaggio totale con maniglia a farfalla / 2 pieces full bore, female-female ball valves with butterfly handle**

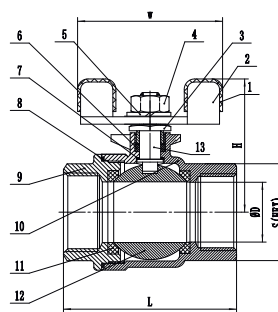

**Modello / Model**  
BV6205M

**Materiale / Material**  
Aisi 316

**Tenuta / Seal**  
PTFE

**DN**  
8 – 25

**PN**  
63

## Caratteristiche tecniche / Construction features

- **Connessioni filettate secondo** / Threaded ends according to UNI EN 10226-1
- **Pressione nominale di esercizio** / Nominal working pressure 63 bar
- **Temperatura di esercizio** / Working temperature  $-10^{\circ}\text{C} - +180^{\circ}\text{C}$
- **Albero anti-espulsione** / Blow-out proof stem

## Diagramma pressione temperatura / Pressure temperature diagram

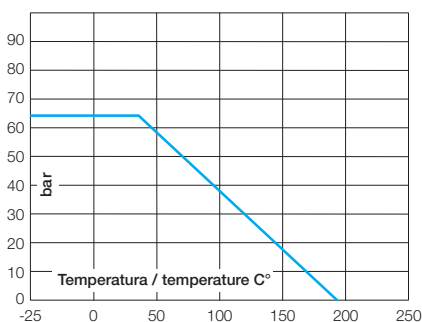

## Componenti e materiali / Components and materials

1	<b>Coprimaniglia</b> / Plastic Cover	Plastica / Plastic
2	<b>Maniglia</b> / Handle	Acciaio inox / SS Aisi 304
3	<b>Premistoppa</b> / Gland Nut	Acciaio inox / SS Aisi 304
4	<b>Dado</b> / Stem Nut	Acciaio inox / SS Aisi 304
5	<b>Rondella</b> / Spring Washer	Acciaio inox / SS Aisi 304
6	<b>Pacco albero</b> / Stem packing	PTFE
7	<b>Rondella</b> / Trust Washer	PTFE
8	<b>Guarnizione</b> / Joint Gasket	PTFE
9	<b>Coperchio</b> / Cap	Acciaio inox / SS Aisi 316
10	<b>Corpo</b> / Body	Acciaio inox / SS Aisi 316
11	<b>Tenuta sfera</b> / Seat ball	PTFE
12	<b>Sfera</b> / Ball	Acciaio inox / SS Aisi 316
13	<b>Albero</b> / Stem	Acciaio inox / SS Aisi 316

## Dimensioni e pesi / Dimensions and weights

Codice Code	Misura Size	DN	PN	Peso in gr. Weight in gr.	KV m <sup>3</sup> /h	Dimensioni in mm Dimensions in mm				
						ØD	L	H	W	S
BV6205M02	1/4"	8	63	188	6	11,6	48,5	40	59	19
BV6205M03	3/8"	10	63	185	10	12,5	48,5	40	59	21
BV6205M04	1/2"	15	63	265	24	15,0	58	46	59	25,5
BV6205M05	3/4"	20	63	385	43	20,0	65	52	63	31
BV6205M06	1"	25	63	545	83	25,0	77	65	73	37,5

M2

# BV6245M

**Valvole a sfera a 2 pezzi maschio-femmina a passaggio totale con maniglia a farfalla** / 2 pieces full bore, male-female ball valves with butterfly handle

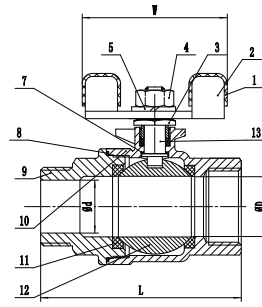

**Modello / Model**  
BV6245M

**Materiale / Material**  
Aisi 316

**Tenuta / Seal**  
PTFE

**DN**  
8 – 25

**PN**  
63

## Caratteristiche tecniche / Construction features

- **Connessioni filettate secondo** / Threaded ends according to UNI EN 10226-1
- **Pressione nominale di esercizio** / Nominal working pressure 63 bar
- **Temperatura di esercizio** / Working temperature  $-10^{\circ}\text{C} - +180^{\circ}\text{C}$
- **Albero anti-espulsione** / Blow-out proof stem

## Diagramma pressione temperatura / Pressure temperature diagram

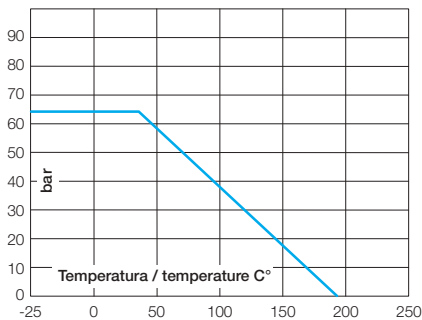

## Componenti e materiali / Components and materials

1	<b>Coprimaniglia</b> / Plastic Cover	Plastica / Plastic
2	<b>Maniglia</b> / Handle	Acciaio inox / SS Aisi 304
3	<b>Premistoppa</b> / Gland Nut	Acciaio inox / SS Aisi 304
4	<b>Dado</b> / Stem Nut	Acciaio inox / SS Aisi 304
5	<b>Rondella</b> / Spring Washer	Acciaio inox / SS Aisi 304
6	<b>Pacco albero</b> / Stem packing	PTFE
7	<b>Rondella</b> / Trust Washer	PTFE
8	<b>Guarnizione</b> / Joint Gasket	PTFE
9	<b>Coperchio</b> / Cap	Acciaio inox / SS Aisi 316
10	<b>Corpo</b> / Body	Acciaio inox / SS Aisi 316
11	<b>Tenuta sfera</b> / Seat ball	PTFE
12	<b>Sfera</b> / Ball	Acciaio inox / SS Aisi 316
13	<b>Albero</b> / Stem	Acciaio inox / SS Aisi 316

## Dimensioni e pesi / Dimensions and weights

Codice Code	Misura Size	DN	PN	Peso in gr. Weight in gr.	KV m <sup>3</sup> /h	Dimensioni in mm Dimensions in mm				
						ØD	Ød	L	H	W
BV6245M02	1/4"	8	63	195	6	11,6	8	55,2	40	59
BV6245M03	3/8"	10	63	193	10	12,5	10,5	55,2	40	59
BV6245M04	1/2"	15	63	295	24	15	13,6	71,5	46	59
BV6245M05	3/4"	20	63	440	43	20	18,2	78	52	63
BV6245M06	1"	25	63	625	83	25	23	91	65	73

M2

## GLOBE / 3V

Valvole a sfera a passaggio ridotto, 3 vie / Reduced bore ball valves, 3 ways

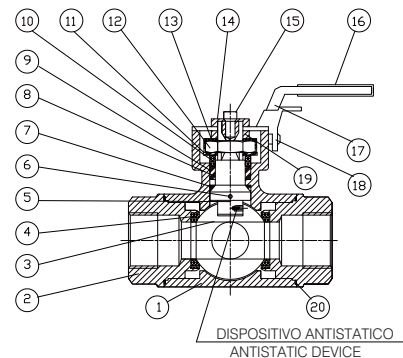

Modello / Model  
**GLOBE 3V**

Materiale / Material  
Aisi 316

Tenuta / Seal  
PTFE + 15% FV / GF

DN  
8 – 65

PN  
63

### Caratteristiche tecniche / Construction features

- **Montaggio diretto attuatore secondo /** Direct actuator installation according to ISO 5211
- **Configurazione flusso /** Flow configuration "L" o/or "T"
- **Connessioni filettate femmina secondo /** Threaded ends female according to UNI EN 10226-1
- **Pressione nominale di esercizio /** Nominal working pressure 63 bar
- **Temperatura di esercizio /** Working temperature  $-25^{\circ}\text{C} - +180^{\circ}\text{C}$
- **Albero anti-espulsione /** Blow-out proof stem
- **Valvole lucchettabili con montaggio diretto attuatore /** With locking system and direct mounting pad
- **Dispositivo antistatico. Questo dispositivo garantisce la continuità elettrica Sfera – Albero – Corpo; ciò risulta particolarmente necessario in presenza di fluidi infiammabili. /** Antistatic device. This device grants the electric continuity between Ball, Stem and Body; this is necessary especially for inflammable fluids.

### Diagramma pressione temperatura / Pressure temperature diagram

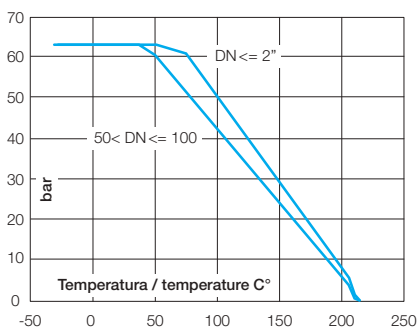

### Componenti e materiali / Components and materials

1	<b>Corpo /</b> Body	Acciaio inox / SS Aisi 316
2	<b>Tappo /</b> Cap	Acciaio inox / SS Aisi 316
3*	<b>Sfera /</b> Ball	Acciaio inox / SS Aisi 316
4*	<b>Tenuta sfera /</b> Seat ball	PTFE + 15% fibra di vetro / PTFE + 15% glass fiber
5	<b>Albero /</b> Stem	Acciaio inox / SS Aisi 316
6	<b>Dispositivo antistatico /</b> Anti-Static device	Acciaio inox / SS Aisi 316
7*	<b>Anello di frizione /</b> Fiction ring	PTFE
8*	<b>O-ring albero /</b> Stem O-ring	FPM
9*	<b>Pacco albero /</b> Stem packing	PTFE
10	<b>Guarnizione /</b> Bushing	Inox. + PTFE / SS + PTFE
11	<b>Premistoppa /</b> Gland	Acciaio inox / SS Aisi 304
12	<b>Dado /</b> Nut	Acciaio inox / SS Aisi 304
13	<b>Dispositivo di blocco /</b> Stopper	Acciaio inox / SS Aisi 304
14	<b>Rondella /</b> Washer	Acciaio inox / SS Aisi 304
15	<b>Vite maniglia /</b> Handle Bolt	Acciaio inox / SS Aisi 304
16	<b>Coprimaniglia /</b> Handle Sleeve	Vinile / Vynil
17	<b>Maniglia /</b> Handle	Acciaio inox / SS Aisi 304
18	<b>Blocco maniglia /</b> Lock device	Acciaio inox / SS Aisi 304
20*	<b>Guarnizione di tenuta /</b> Gasket	PTFE
21	<b>Vite di fermo /</b> Stop Bolt	Acciaio inox / SS Aisi 304

\* **Ricambi disponibili /** Spare parts

Su richiesta /  
On request

Filettatura NPT / NPT thread



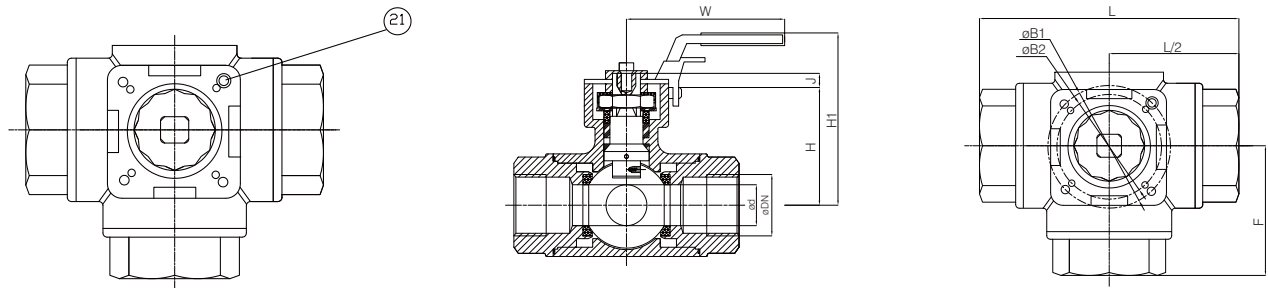

### Dimensioni e pesi / Dimensions and weights

Codice Code	Versione Type	Misura Size	DN	PN	Peso in kg. Weight in kg.	KV m <sup>3</sup> /h	Dimensioni in mm Dimensions in mm							
							Ød	L	H	H1	W	J	F	ISO 5211
901001	L	1/4"	8	63	0,70	11	9,5	75	37	66	130	8	37	F03 / F04
901002		3/8"	10	63	0,67	11	11	75	37	66	130	8	37	F03 / F04
901003		1/2"	15	63	0,63	13	12	75	37	66	130	8	37	F03 / F04
901004		3/4"	20	63	0,95	15	15	85	41	72	161	12	42	F04 / F05
901005		1"	25	63	1,40	31	20	100	47	77	161	12	50	F04 / F05
901006		1" 1/4	32	63	2,90	39	25	122	56	92	203	12	61	F05 / F07
901007		1" 1/2	40	63	3,60	62	32	131	60	96	203	12	65	F05 / F07
901008		2"	50	63	6,25	103	40	158	71	107	203	12	79	F05 / F07
901009		2"1/2	65	63	8,95	205	49	178	95	135	254	14	89	F07 / F10
901010	T	1/4"	8	63	0,70	11	9,5	75	37	66	130	8	37	F03 / F04
901011		3/8"	10	63	0,67	11	11	75	37	66	130	8	37	F03 / F04
901012		1/2"	15	63	0,63	13	12	75	37	66	130	8	37	F03 / F04
901013		3/4"	20	63	0,95	15	15	85	41	72	161	12	42	F04 / F05
901014		1"	25	63	1,40	31	20	100	47	77	161	12	50	F04 / F05
901015		1" 1/4	32	63	2,90	39	25	122	56	92	203	12	61	F05 / F07
901016		1" 1/2	40	63	3,60	62	32	131	60	96	203	12	65	F05 / F07
901017		2"	50	63	6,25	103	40	158	71	107	203	12	79	F05 / F07
901018		2"1/2	65	63	8,72	205	49	178	95	135	254	14	89	F07 / F10

### Schema passaggio fluido / Fluid flow diagram



M2

## H2118

Valvole a sfera  
tipo wafer / Wafer  
ball valves

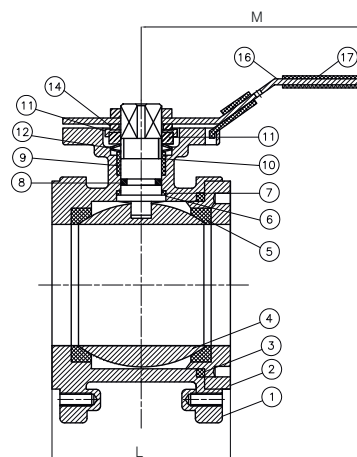

Modello / Model  
**H2118**

Materiale / Material  
Aisi 316

Tenuta / Seal  
PTFE + 15% FV / GF

DN  
15 – 100

PN  
16

### Caratteristiche tecniche / Construction features

- **Montaggio diretto attuatore secondo /**  
Direct actuator installation according to  
ISO 5211
- **Montaggio tra flange secondo /** Assembly  
between flanges according to  
EN 1092 PN16
- **Pressione nominale di esercizio /**  
Nominal working pressure  
16 bar
- **Temperatura di esercizio /** Working  
temperature  
-20°C – +180°C
- **Albero anti-espulsione /**  
Blow-out proof stem

### Diagramma pressione temperatura / Pressure temperature diagram

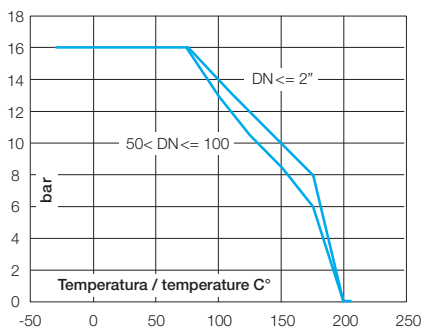

### Componenti e materiali / Components and materials

1	<b>Corpo</b> / Body	Acciaio inox / SS Aisi 316
2	<b>Tappo</b> / Cap	Acciaio inox / SS Aisi 316
3*	<b>Tenute</b> / Gasket	PTFE
4	<b>Sfera</b> / Ball	Acciaio inox / SS Aisi 316
5*	<b>Tenuta sfera</b> / Seat ball	PTFE + 15% fibra di vetro / PTFE + 15% glass fiber
6	<b>Albero</b> / Stem	Acciaio inox / SS Aisi 316
7*	<b>Rondella</b> / Trust Washer	PTFE
8*	<b>Anello OR</b> / O-ring	FPM
9*	<b>Pacco albero</b> / Stem packing	PTFE
10	<b>Anello albero</b> / Stem ring	Acciaio inox / SS Aisi 304
11	<b>Dado</b> / Nut	Acciaio inox / SS Aisi 304
12	<b>Rondella molla</b> / Spring washer	Acciaio inox / SS Aisi 304
13	<b>Antisvitamento</b> / Lock washer	Acciaio inox / SS Aisi 304
14	<b>Rondella</b> / Washer	Acciaio inox / SS Aisi 304
15	<b>Fermo corsa</b> / Stop pin	Acciaio inox / SS Aisi 304
16	<b>Maniglia</b> / Handle	Acciaio inox / SS Aisi 304
17	<b>Coprimaniglia</b> / Handle Sleeve	Vinile / Vynil

\* **Ricambi disponibili** / Spare parts

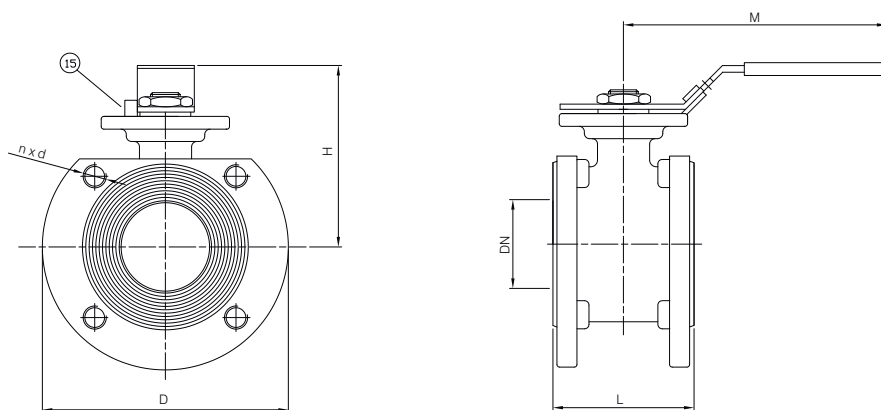

### Dimensioni e pesi / Dimensions and weights

Codice Code	Misura Size	DN	PN	Peso in kg. Weight in kg.	KV m <sup>3</sup> /h	Dimensioni in mm Dimensions in mm					
						L	M	D	H	n x d	ISO 5211
H211804	1/2"	15	16	1,70	24	36	115	95	85	4 x M12	F-03/F-04
H211805	3/4"	20	16	1,90	43	38	115	105	90	4 x M12	F-03/F-04
H211806	1"	25	16	2,50	83	50	170	115	95	4 x M12	F-04/F-05
H211807	1" 1/4	32	16	3,50	130	53	170	140	100	4 x M16	F-04/F-05
H211808	1" 1/2	40	16	4,35	205	65	210	150	105	4 x M16	F-05/F-07
H211809	2"	50	16	5,45	340	78	210	165	115	4 x M16	F-05/F-07
H211810	2" 1/2	65	16	7,80	520	98	260	185	130	4 x M16	F-07/F-10
H211811	3"	80	16	10,30	1.100	118	260	200	145	8 x M16	F-07/F-10
H211812	4"	100	16	18,00	1.820	140	260	220	175	8 x M16	F-07/F-10

M2

## H5985

**Maniglia con ritorno a molla\*** / Manual device with spring return\*

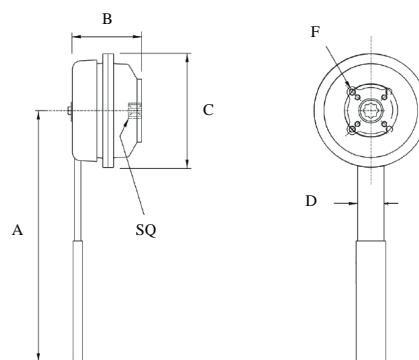

**Modello / Model**  
H5985

**Materiale / Material**  
Lega di zinco / Zinc alloy + Aisi 316 - Aisi 304

**Temperatura di esercizio / Working temperature**  
-40°C – +80°C

### Caratteristiche tecniche / Construction features

- **Garantisce che la valvola resti sempre in posizione di sicurezza. Questo accessorio garantisce che la valvola non rimanga accidentalmente aperta o comunque in posizione indesiderata mediante un sistema a molle che garantisce il ritorno alla posizione originale.** / Total safety for the valve to be closed. This device prevents the valve from being accidentally opened or in the wrong position as it ensures return to the original position by a spring.
- **Rotazione in senso orario** / Clockwise rotation  
90°
- **Montaggio diretto attuatore secondo** / Direct actuator installation according to ISO 5211
- **Temperatura di esercizio** / Working temperature  
-40°C – +80°C
- **Esente da manutenzione** / Maintenance free
- **Ideale per punti di prelievo campioni, per valvole di spurgo o per riempimento e svuotamento serbatoi.** / Ideal for sampling systems, purges or applications for emptying or filling tanks.
- **Protezione** / Protection  
IP 65

### Componenti e materiali / Components and materials

<b>Carcassa</b> / Housing	Lega di Zinco / Zinc alloy
<b>Trattamento superficiale</b> / Surface treatment	Epoxy coating / Epoxy coating
<b>Maniglia</b> / Handle	Acciaio inox / SS Aisi 304
<b>Albero</b> / Stem	Acciaio inox / SS Aisi 316

### Dimensioni e pesi / Dimensions and weights

Codice Code	Peso in kg. Weight in kg.	Dimensioni in mm Dimensions in mm						Coppia Torque	
		A	B	C	D	SQ	F	Inizio / Start	Fine / End
H5985 02	1,87	238	66	108	25	11 x 11	F03/F05	14	11
H5985 07	1,87	238	62	118	25	14 x 14	F03/F05/F07	24	20,5
H5985 09	5,17	360	103	152	25	17 x 17	F05/F07	45.5	39.7

\* **Valvola non compresa nella fornitura** / Valve is sold separately

M2

# H5330 - H5332

**Prolunga per valvola manuale\*** / Extension for manual valve\*



Versione con blocco /  
Version with locking system

**Modello / Model**  
**H5330-H5332**

**Materiale / Material**  
Aisi 316

## Dimensioni e pesi / Dimensions and weights

Codice Code	Versione Type	Valvole Compatibili Compatibles valves		Misura Size
		H2015 Globe 3P	Globe 3V	
H533009050	Standard	1/4" - 1/2"	1/4" - 1/2"	50 mm
H533009100		1/4" - 1/2"	1/4" - 1/2"	100 mm
H533011050		3/4" - 1"	3/4" - 1"	50 mm
H533011100		3/4" - 1"	3/4" - 1"	100 mm
H533014050		1" 1/4 - 2"	1" 1/4 - 2"	50 mm
H533014100		1" 1/4 - 2"	1" 1/4 - 2"	100 mm
H533017050		2" 1/2 - 4"	-	50 mm
H533017100		2" 1/2 - 4"	-	100 mm
H533209050	Con blocco / With locking system	1/4" - 1/2"	1/4" - 1/2"	50 mm
H533209100		1/4" - 1/2"	1/4" - 1/2"	100 mm
H533211050		3/4" - 1"	3/4" - 1"	50 mm
H533211100		3/4" - 1"	3/4" - 1"	100 mm
H533214050		1" 1/4 - 2"	1" 1/4 - 2"	50 mm
H533214100		1" 1/4 - 2"	1" 1/4 - 2"	100 mm
H533217050		2" 1/2 - 4"	-	50 mm
H533217100		2" 1/2 - 4"	-	100 mm

\* Valvola non compresa nella fornitura / Valve is sold separately

M2

## H2104

**Valvole wafer a farfalla** / Butterfly valves wafer type



**Modello / Model**  
H2104

**Materiale / Material**  
Aisi 316

**Tenuta / Seal**  
PTFE - EPDM

**DN**  
50 – 250

**PN**  
10

### Caratteristiche tecniche / Construction features

- **Montaggio diretto attuatore secondo** / Direct actuator installation according to ISO 5211
- **Montaggio tra flange secondo** / Assembly between flanges according to EN 1092 PN 10/16 - ANSI 150
- **Scartamento tra le facce secondo** / Face to face distances according to EN 558-1 Serie/series 20
- **Temperatura di esercizio** / Working temperature -25°C – +180°C
- **Con riduttore a volantino di serie per versioni DN150, DN200 e DN250. Su richiesta per misure inferiori** / Gear operator included for versions DN150, DN200, DN250. On request for other sizes

### Diagramma pressione temperatura / Pressure temperature diagram

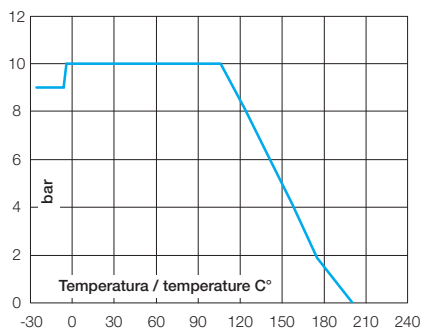

### Componenti e materiali / Components and materials

<b>1</b>	<b>Corpo</b> / Body	Acciaio inox / SS Aisi 316
	<b>Trattamento superficiale</b> / Surface treatment	Granigliatura / Shot blasting
<b>2</b>	<b>Albero superiore</b> / Upside stem	Acciaio inox / SS Aisi 316
<b>3</b>	<b>Albero inferiore</b> / Low stem	Acciaio inox / SS Aisi 316
<b>4*</b>	<b>Tenuta</b> / Seal	PTFE su base EPDM / PTFE on EPDM
<b>5</b>	<b>Disco</b> / Disc	Acciaio inox / SS Aisi 316
	<b>Trattamento superficiale</b> / Surface treatment	Granigliatura / Shot blasting
<b>6</b>	<b>Camicia</b> / Sleeve	RPTFE
<b>7</b>	<b>Rondella molla</b> / Spring washer	Acciaio inox / SS Aisi 301
<b>8</b>	<b>Anello OR</b> / O-ring	FPM
<b>9</b>	<b>Boccola</b> / Bush	RPTFE
<b>10</b>	<b>Rondella</b> / Washer	Acciaio inox / SS Aisi 304
<b>11</b>	<b>Seeger albero</b> / Shaft retainer	Acciaio inox / SS Aisi 304
<b>12</b>	<b>Seeger OR</b> / OR retainer	Acciaio inox / SS Aisi 304
<b>13</b>	<b>Maniglia</b> / Handle	Acciaio inox / SS Aisi 304
	<b>Trattamento superficiale</b> / Surface treatment	Lucidato / Polished
<b>14</b>	<b>Piatto</b> / Plate	Acciaio inox / SS Aisi 304
	<b>Trattamento superficiale</b> / Surface treatment	Lucidato / Polished

\* **Ricambi disponibili** / Spare parts

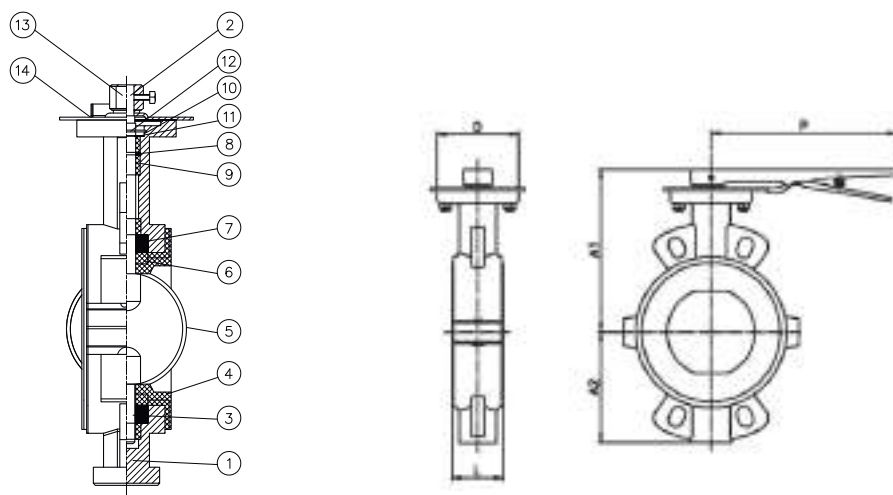

### Dimensioni e pesi / Dimensions and weights

Codice Code	Misura Size	DN	PN	Peso in kg. Weight in kg.	KV m <sup>3</sup> /h*	Dimensioni in mm Dimensions in mm					
						L	A1	A2	D	P	ISO 5211
H210409	2"	50	10	2,70	125	43	168	74	65	264	F05
H210410	2" 1/2	65	10	3,30	244	46	170	82	65	264	F05
H210411	3"	80	10	3,60	399	46	170	90	65	264	F05
H210412	4"	100	10	5,40	727	52	190	116	90	264	F07
H210413	5"	125	10	7,40	1.190	56	206	132	90	264	F07
H210414	6"	150	10	10,50	1.600	56	222	145	90	-	F07
H210416	8"	200	10	18,10	2.868	60	274	180	125	-	F10
H210418	10"	250	10	24,90	4.713	68	264	210	125	-	F10

\* Disco a 90° / Disc position 90°

M2

## H2101

**Valvola a farfalla di tipo wafer /**  
Butterfly valve wafer type

**Valvola a farfalla wafer per**  
**montaggio tra flange /** Butterfly  
valve installation between flanges



DN 150 - 200

Modello / Model

H2101

Materiale / Material

EN-GJS-400 - Aisi 316

Tenuta / Seal

PTFE

DN

50 - 200

PN

10

### Caratteristiche tecniche /

Construction features

- **Montaggio diretto attuatore secondo /**  
Direct actuator installation according to  
ISO 5211
- **Montaggio tra flange secondo /** Assembly  
between flanges according to  
EN 1092 PN 10/16 - ANSI 150
- **Scartamento tra le facce /**  
Face to face according to  
EN 558-1 Serie / series 20
- **Temperatura di esercizio /**  
Working temperature  
-25°C - + 180°C
- **Con riduttore a volantino di serie per**  
**versioni DN150 e DN200. Su richiesta per**  
**misure inferiori /** Gear operator included for  
versions DN150 and DN200. On request for  
other sizes

### Diagramma pressione temperatura /

Pressure temperature diagram

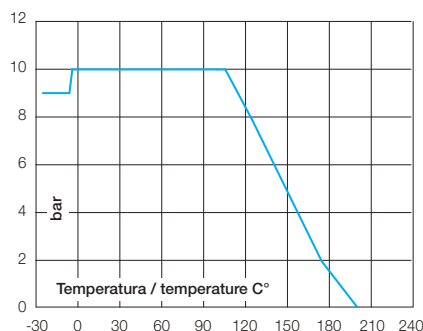

### Componenti e materiali /

Components and materials

1	<b>Corpo Inferiore /</b> Downside Body	Ghisa nodulare / Ductile Iron EN-GJS-400		
	<b>Trattamento superficiale /</b> Surface treatment	Vernice epossidica / Epoxy		
2	<b>Corpo Superiore /</b> Upside Body	Ghisa nodulare / Ductile Iron EN-GJS-400		
	<b>Trattamento superficiale /</b> Surface treatment	Vern. epossidica / Epoxy		
3	<b>Albero Superiore /</b> Upside Stem	Acciaio inox / SS Aisi 316		
4	<b>Albero Inferiore /</b> Downside Stem	Acciaio inox / SS Aisi 316		
5*	<b>Tenuta /</b> Seal	PTFE (Silicone core)		
6	<b>Disco /</b> Disc	Acciaio inox / SS Aisi 316		
	<b>Trattamento superficiale /</b> Surface treatment	Lucidato / Polished		
7	<b>Boccola /</b> Hub	Nylon		
8	<b>Rondella molla /</b> Spring washer	Acciaio / Steel		
	<b>Trattamento superficiale /</b> Surface treatment	Dacromet		
9	<b>Anello OR /</b> O-ring	FPM		
10	<b>Manicotto /</b> Bush	RPTFE		
11	<b>Rondella /</b> Washer	Acciaio / Steel		
	<b>Trattamento superficiale /</b> Surface treatment	Trattamento galvanico / Galvanized		
12	<b>Rondella Seeger /</b> Seeger ring	Acciaio / Steel		
	<b>Trattamento superficiale /</b> Surface treatment	Trattamento galvanico / Galvanized		
13	<b>Maniglia /</b> Handle	Alluminio / Aluminium		
	<b>Trattamento superficiale /</b> Surface treatment	Vern. epossidica / Epoxy		
14	<b>Piatto /</b> Plate	Acciaio / Steel		
	<b>Trattamento superficiale /</b> Surface treatment	Trattamento galvanico / Galvanized		
15	<b>Vite-Dado /</b> Screw-Nut	Acciaio / Steel		
	<b>Trattamento superficiale /</b> Surface treatment	Trattamento galvanico / Galvanized		
16	<b>Vite /</b> Screw	Acciaio / Steel		
	<b>Trattamento superficiale /</b> Surface treatment	Trattamento galvanico / Galvanized		
	* <b>Ricambi disponibili /</b> Spare parts			



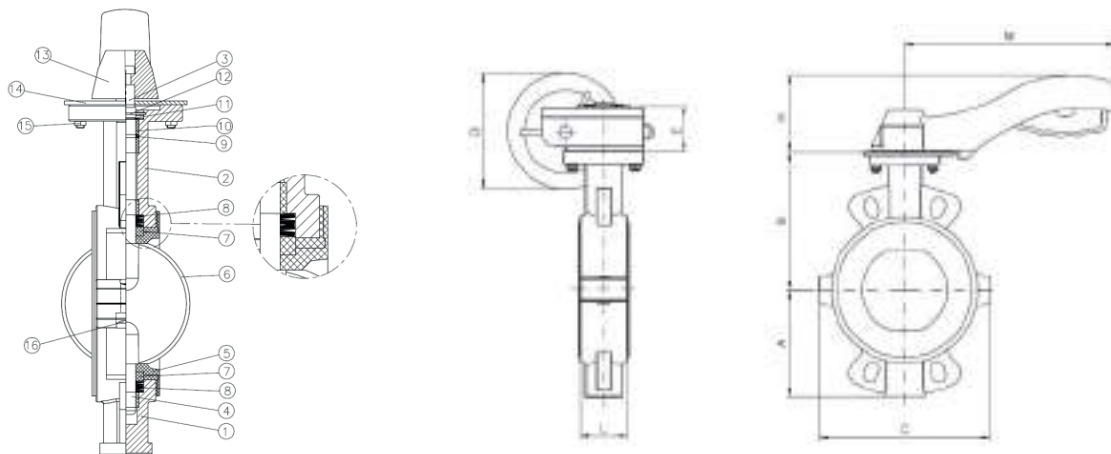

### Dimensioni e pesi / Dimensions and weights

Codice Code	Misura Size	DN	PN	Peso in kg. Weight in kg.	KV m <sup>3</sup> /h*	Dimensioni in mm Dimensions in mm								
						L	A	B	C	D	E	H	M	ISO 5211
H210109	2"	50	10	2,90	125	43	80	140	119	-	-	65	172	F05
H210110	2" 1/2	65	10	3,18	244	46	89	150	131	-	-	65	172	F05
H210111	3"	80	10	3,55	399	46	95	158	145	-	-	65	172	F05
H210112	4"	100	10	5,53	727	52	114	176	180	-	-	78	216	F07
H210113	5"	125	10	6,87	1.190	56	127	190	202	-	-	78	216	F07
H210114	6"	150	10	8,25	1.600	56	139	210	230	150	72	-	-	F07
H210116	8"	200	10	17,40	2.868	60	175	236	295	300	85	-	-	F10

\* Disco a 90° / Disc position 90°

M3

# H2103 - H2109

Valvole wafer a farfalla /  
Butterfly valves wafer type

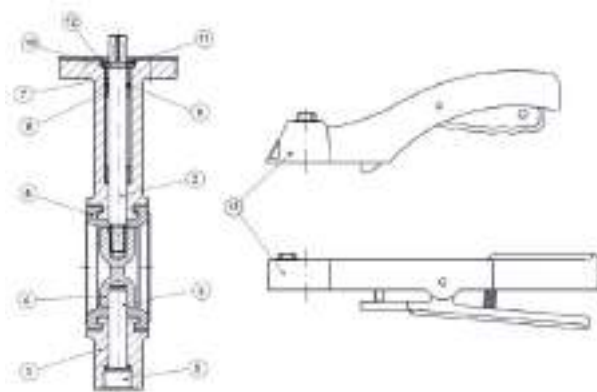

Modello / Model  
**H2103 - H2109**

Materiale / Material  
Ghisa - Cast iron

Tenuta / Seal  
EPDM

DN  
50 - 200

PN  
16

## Caratteristiche tecniche / Construction features

- **Montaggio diretto attuatore secondo /**  
Direct actuator installation according to  
ISO 5211
- **Montaggio tra flange secondo /** Assembly  
between flanges according to  
EN 1092 PN 10/16 - ANSI 150
- **Scartamento tra le facce secondo /**  
Face to face distances according to  
UNI EN 558-1 serie/series 20
- **Temperatura di esercizio /** Working  
temperature  
-20°C - +120°C
- **Certificazioni /** Approvals  
 WRAS
- **Con riduttore a volantino di serie per**  
**versioni DN150 e DN200. Su richiesta per**  
**misure inferiori /** Gear operator included for  
versions DN150 and DN200. On request for  
other sizes

## Diagramma pressione temperatura / Pressure temperature diagram

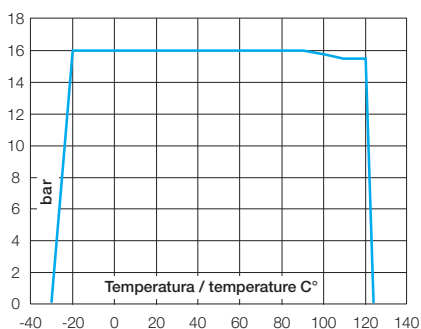

## Componenti e materiali / Components and materials

<b>1</b>	<b>Corpo /</b> Body	Ghisa EN-GJL-200 Cast iron / EN-GJL-200 type
	<b>Trattamento superficiale /</b> Surface treatment	Vernice epossidica Epoxy
<b>2</b>	<b>Albero /</b> Stem	Acciaio inox / SS Aisi 416
<b>3</b>	<b>Albero inferiore /</b> Low stem	Acciaio inox / SS Aisi 416
<b>4</b>	<b>Disco modello /</b> Disc model <b>H2103</b>	Ghisa EN-GJS-400 Ductile iron EN-GJS-400 type
<b>4</b>	<b>Disco modello /</b> Disc model <b>H2109</b>	Acciaio inox / SS Aisi 316
<b>5</b>	<b>Tappo /</b> Plug	Acciaio al carbonio / Carbon steel
<b>6*</b>	<b>Tenuta /</b> Seal	EPDM
<b>7</b> <b>8</b>	<b>Boccola /</b> Bush	PTFE + grafite / PTFE + graphite
<b>9</b>	<b>Anello OR /</b> O-ring	NBR
<b>10</b>	<b>Rondella /</b> Washer	Bronzo / Bronze
<b>11</b>	<b>Anello di fermo /</b> Stop ring	Acciaio al carbonio / Carbon steel
<b>12</b>	<b>Piatto dentato /</b> Plate	Acciaio al carbonio / Carbon steel
<b>13</b>	<b>Maniglia /</b> Handle	Alluminio da 2" a 6" o Ghisa / EN-GJL-200 per 8" / Aluminum from 2" to 6" or Cast iron EN-GJL-200 type for 8"

\* **Ricambi disponibili /** Spare parts

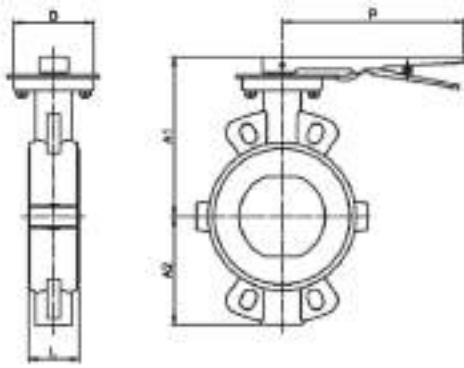

### Dimensioni e pesi / Dimensions and weights

Codice Code	Materiale Material	Misura Size	DN	PN	Peso in kg. Weight in kg.	KV m <sup>3</sup> /h*	Dimensioni in mm Dimensions in mm					
							L	A1	A2	D	P	F (ISO 5211)
H210309	Iron +	2"	50	16	2,80	125	43	238	70	65	170	F05
H210310		Iron	2" 1/2	65	16	3,30	244	46	238	80	65	170
H210311		3"	80	16	3,80	399	46	238	100	65	170	F05
H210312		4"	100	16	5,80	727	52	270	115	90	215	F07
H210313		5"	125	16	7,40	1.190	56	300	135	90	215	F07
H210314		6"	150	16	8,35	1.600	56	300	150	90	215	F07
H210316		8"	200	16	14,4	2.868	60	280	180	125	300	F07/F10
H210909	Iron +	2"	50	16	2,80	125	43	238	70	65	170	F05
H210910		Aisi 316	2" 1/2	65	16	3,30	244	46	238	80	65	170
H210911		3"	80	16	3,80	399	46	238	100	65	170	F05
H210912		4"	100	16	5,80	727	52	270	115	90	215	F07
H210913		5"	125	16	7,40	1.190	56	300	135	90	215	F07
H210914		6"	150	16	8,35	1.600	56	300	150	90	215	F07
H210916		8"	200	16	14,40	2.868	60	280	180	125	300	F07/F10

\* Disco a 90° / Disc position 90°

M3

## H2108

Valvole a farfalla  
tipo lug / Butterfly  
valves lug type

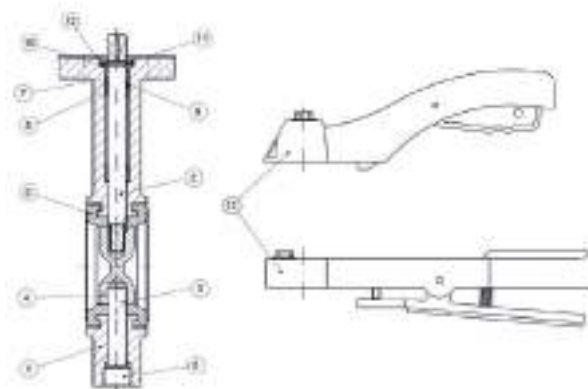

Modello / Model

H2108

Materiale / Material

Ghisa - Cast iron

Tenuta / Seal

EPDM

DN

50 - 200

PN

10 - 16

### Caratteristiche tecniche / Construction features

- **Montaggio diretto attuatore secondo /**  
Direct actuator installation according to  
ISO 5211
- **Montaggio tra flange secondo /** Assembly  
between flanges according to  
EN 1092 PN 10/16
- **Scartamento tra le facce secondo /**  
Face to face distances according to  
UNI EN 558-1 serie/series 20
- **Temperatura di esercizio /** Working  
temperature  
-20°C - +120°C
- **Certificazioni /** Approvals



WRAS

- **Con riduttore a volantino di serie per**  
**versioni DN150 e DN200. Su richiesta per**  
**misure inferiori /** Gear operator included for  
versions DN150 and DN200. On request for  
other sizes

### Diagramma pressione temperatura / Pressure temperature diagram

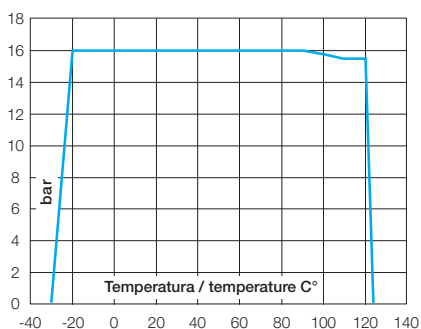

### Componenti e materiali / Components and materials

1	<b>Corpo /</b> Body	Ghisa EN-GJS-400 / Ductile iron EN-GJS-400 type
	<b>Trattamento superficiale /</b> Surface treatment	Vernice epossidica / Epoxy
2	<b>Albero /</b> Stem	Acciaio inox / SS Aisi 416
3	<b>Albero inferiore</b> Low stem	Acciaio inox / SS Aisi 416
4	<b>Disco /</b> Disc	Acciaio inox / SS Aisi 316
5	<b>Tappo /</b> Plug	Acciaio al carbonio / Carbon steel
6*	<b>Tenuta /</b> Seal	EPDM
7	<b>Boccola /</b> Bush	PTFE + grafite / graphite
8		
9	<b>Anello OR /</b> O-ring	NBR
10	<b>Rondella /</b> Washer	Bronzo / Bronze
11	<b>Anello di fermo /</b> Stop ring	Acciaio al carbonio / Carbon steel
12	<b>Piatto dentato /</b> Plate	Acciaio al carbonio / Carbon steel
13	<b>Maniglia /</b> Handle	Alluminio da 2" a 5" o Ghisa EN-GJL-200 per 6" e 8" / Aluminum from 2" to 5" or Cast iron EN-GJL-200 type for 6" and 8"

\* **Ricambi disponibili /** Spare parts

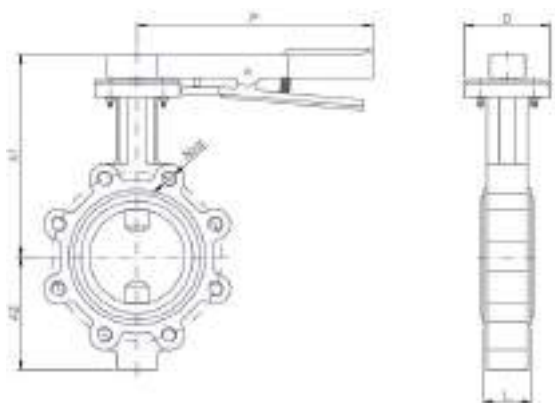

### Dimensioni e pesi / Dimensions and weights

Codice Code	Misura Size	DN	PN	Peso in kg. Weight in kg.	KV m <sup>3</sup> /h*	Dimensioni in mm Dimensions in mm						
						L	A1	A2	D	P	F (ISO 5211)	n x d
H210809	2"	50	16	4,8	125	43	240	79	90	216	F07	4 x M16
H210810	2" 1/2	65	16	5,5	244	46	240	93	90	216	F07	4 x M16
H210811	3"	80	16	7,0	399	46	245	103	90	216	F07	8 x M16
H210812	4"	100	16	8,1	727	52	265	120	90	216	F07	8 x M16
H210813	5"	125	16	10,9	1.190	56	290	133	90	216	F07	8 x M16
H210814	6"	150	16	14,0	1.600	56	240	158	125	300	F07/F10	8 x M20
H210816	8"	200	10	19,4	2.868	60	280	180	125	300	F07/F10	8 x M20

\* Disco a 90° / Disc position 90°

M2

## H2220

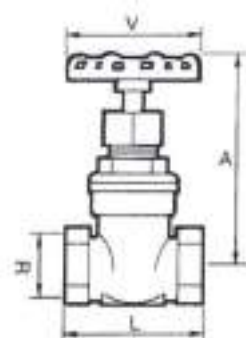
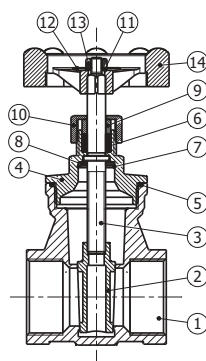
Valvole a saracinesca /  
Gate valvesModello / Model  
**H2220**Materiale / Material  
Aisi 316Tenuta / Seal  
Metallica / MetallicDN  
15 – 50PN  
16Caratteristiche tecniche /  
Construction features

- **Conessioni filettate gas secondo** /  
Threaded ends gas according to  
EN 10226-1 (ISO 7-1)
- **Pressione massima di esercizio** /  
Maximum working pressure  
16 bar
- **Temperatura di esercizio** /  
Working temperature  
-30°C – +180°C

Componenti e materiali /  
Components and materials

1	<b>Corpo</b> / Body	Acciaio inox / SS Aisi 316
2	<b>Saracinesca</b> / Wedge	Acciaio inox / SS Aisi 316
3	<b>Albero</b> / Stem	Acciaio inox / SS Aisi 316
4	<b>Coperchio</b> / Cap	Acciaio inox / SS Aisi 316
5	<b>Guarnizione corpo</b> Body gasket	PTFE
6	<b>Pacco albero</b> / Stem packing	PTFE
7	<b>Anello</b> / Ring	Acciaio inox / SS Aisi 316
8	<b>Rondella</b> / Washer	Acciaio inox / SS Aisi 304
9	<b>Anello di giuntura</b> / Packing ring	Acciaio inox / SS Aisi 316
10	<b>Dado di giuntura</b> / Packing nut	Acciaio inox / SS Aisi 316
11	<b>Rondella</b> / Washer	Acciaio inox / SS Aisi 304
12	<b>Disco indicatore</b> / Indicator disc	Alluminio serigrafato / Printed aluminium
13	<b>Dado</b> / Nut	Acciaio inox / SS Aisi 304
14	<b>Volantino</b> / Handweel	Alluminio verniciato / Painted aluminium

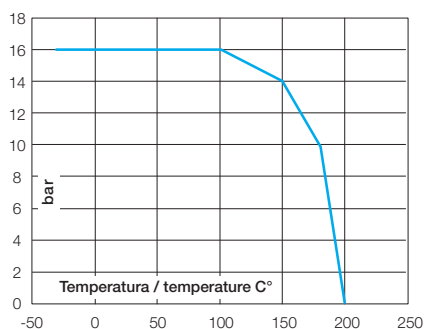
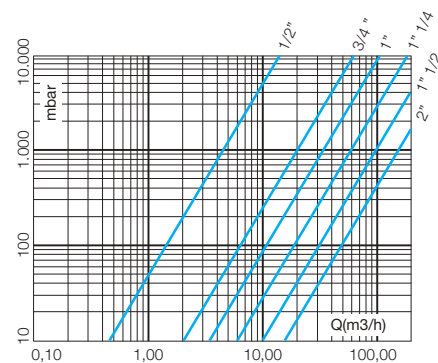
Diagramma pressione temperatura /  
Pressure temperature diagramPerdite di carico /  
Friction losses diagramsDimensioni e pesi /  
Dimensions and weights

Codice Code	Misura Size	DN	PN	Peso in kg. Weight in kg.	KV m³/h	Dimensioni in mm Dimensions in mm			
						R	A	L	V
H222004	1/2"	15	16	0,414	4,5	1/2"	100	55	70
H222005	3/4"	20	16	0,578	20	3/4"	110	61	70
H222006	1"	25	16	0,740	34	1"	115	68	70
H222007	1" 1/4	32	16	0,995	60	1" 1/4	130	77	80
H222008	1" 1/2	40	16	1,550	102	1" 1/2	150	80	100
H222009	2"	50	16	2,150	161	2"	167	93	100

Su richiesta /  
On request

Filettatura NPT / NPT thread

M2

## H2230

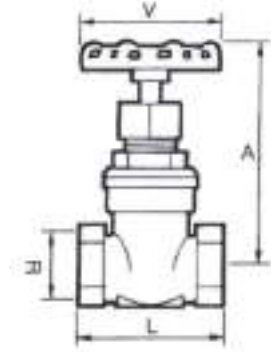
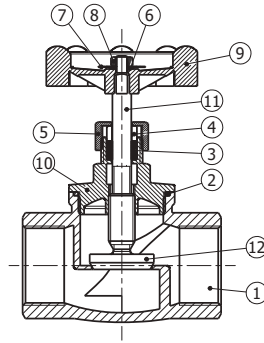
Valvole a globo /  
Globe valvesModello / Model  
H2230Materiale / Material  
Aisi 316Tenuta / Seal  
Metallica / MetallicDN  
15 - 50PN  
16Caratteristiche tecniche /  
Construction features

- **Connessioni filettate secondo /**  
Threaded ends according to  
EN 10226-1 (ISO 7-1)
- **Pressione massima di esercizio /**  
Maximum working pressure  
16 bar
- **Temperatura massima di esercizio /**  
Maximum working temperature  
180°C

Componenti e materiali /  
Components and materials

1	Corpo / Body	Acciaio inox / SS Aisi 316
2	Guarnizione corpo Body Gasket	PTFE
3	Pacco albero / Stem packing	PTFE
4	Anello di giuntura Stem packing	Acciaio inox / SS Aisi 316
5	Dado di giuntura / Packing nut	Acciaio inox / SS Aisi 316
6	Rondella piana / Washer	Acciaio inox / SS Aisi 304
7	Dischetto indicatore / Indicator disc	Alluminio serigrafato / Printed aluminium
8	Dado / Nut	Acciaio inox / SS Aisi 316
9	Volantino / Handwheel	Alluminio verniciato / Painted aluminium
10	Coperchio / Cap	Acciaio inox / SS Aisi 316
11	Albero / Stem	Acciaio inox / SS Aisi 316
12	Otturatore / Closing disc	Acciaio inox / SS Aisi 316

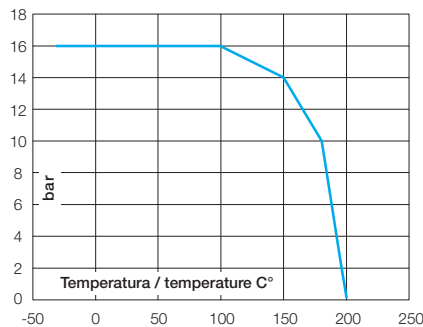
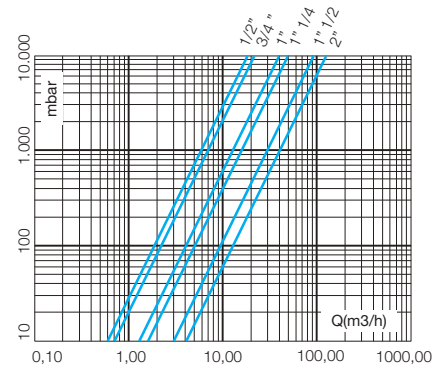
Diagramma pressione temperatura /  
Pressure temperature diagramPerdite di carico /  
Friction losses diagramsDimensioni e pesi /  
Dimensions and weights

Codice Code	Misura Size	DN	PN	Peso in kg. Weight in kg.	KV m³/h*	Dimensioni in mm Dimensions in mm			
						R	A*	L	V
H223004	1/2"	15	16	0,38	5,9	1/2"	97	65	70
H223005	3/4"	20	16	0,60	7	3/4"	103	75	70
H223006	1"	25	16	0,85	13	1"	116	90	70
H223007	1" 1/4	32	16	1,36	16	1" 1/4	135	105	80
H223008	1" 1/2	40	16	1,88	30	1" 1/2	152	120	100
H223009	2"	50	16	2,68	41	2"	164	140	100

\* Valvola aperta / Open valve

Su richiesta /  
On request

Filettatura NPT / NPT thread

M3

H2221

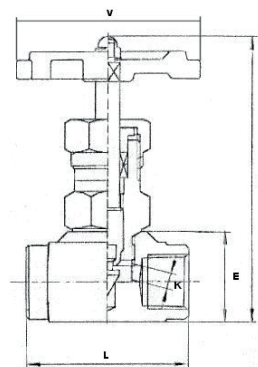
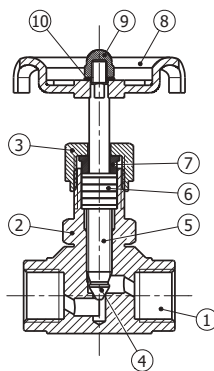
Valvole a spillo /  
Needle valvesModello / Model  
H2221Materiale / Material  
A105Tenuta / Seal  
Metallica / MetallicDN  
8 - 25PN  
200Caratteristiche tecniche /  
Construction features

- **Connessioni filettate gas secondo /**  
Threaded ends gas according to  
ISO 228/1
- **Pressione massima di esercizio /**  
Maximum working pressure  
200 bar (3000 Lbs)
- **Temperatura massima di esercizio /**  
Maximum working temperature  
240°C

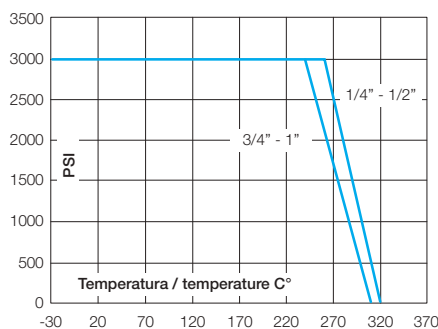
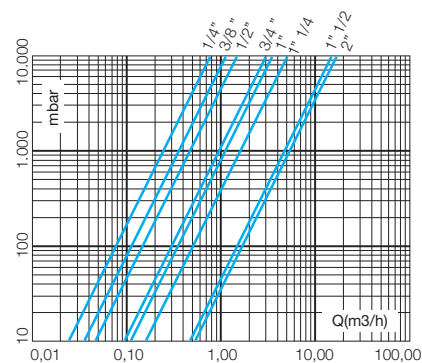
Diagramma pressione temperatura /  
Pressure temperature diagramPerdite di carico /  
Friction losses diagramsDimensioni e pesi /  
Dimensions and weights

Codice Code	Misura Size	DN	PN	Peso in kg. Weight in kg.	KV m³/h	Dimensioni in mm Dimensions in mm				
						E	H	L	K	V
H222102	1/4"	8	200	0,26	0,25	25	85	50	3	63
H222103	3/8"	10	200	0,36	0,36	30	100	55	4	63
H222104	1/2"	15	200	0,53	0,47	34	115	60	6	72
H222105	3/4"	20	200	0,76	0,95	40	120	70	8	72
H222106	1"	25	200	1,18	1,1	45	138	75	9	80

Componenti e materiali /  
Components and materials

1	Corpo / Body	ASTM A-105
2	Coperchio / Cap	ASTM A-105
3	Dado premistoppa / Nut	ASTM A-105
4	Spillo / Needle	Acciaio inox A182 F6 / SS A182 F6
5	Albero / Stem	Acciaio inox A182 F6 / SS A182 F6
6	Pacco albero / Stem packing	PTFE + grafite / PTFE + graphite
7	Premistoppa / Packing nut	ASTM A-105
8	Volantino / Handwheel	Ghisa / Cast iron
9	Dado / Nut	Acciaio al carbonio / Carbon steel
10	Rondella / Washer	Acciaio al carbonio / Carbon steel

Su richiesta /  
On request

Filettatura NPT / NPT thread



M2

H2223

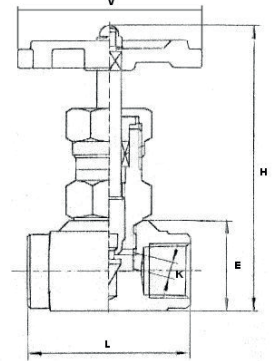
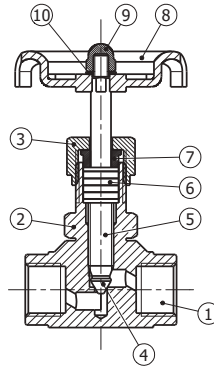
Valvole a spillo /  
Needle valvesModello / Model  
H2223Materiale / Material  
Aisi 316Tenuta / Seal  
Metallica / MetallicDN  
8 - 50PN  
200Caratteristiche tecniche /  
Construction features

- **Connessioni filettate femmina secondo /**  
Threaded ends female according to  
ISO 228/1
- **Pressione massima di esercizio /**  
Maximum working pressure  
200 bar (3000 Lbs)
- **Temperatura massima di esercizio /**  
Maximum working temperature  
240°C

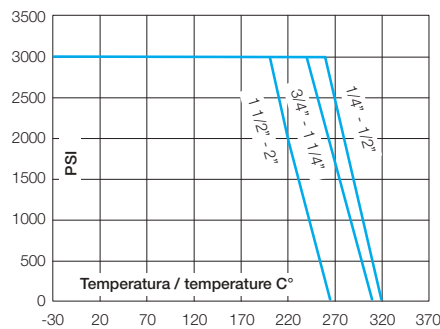
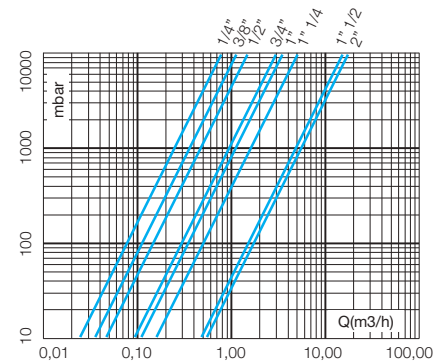
Diagramma pressione temperatura /  
Pressure temperature diagramPerdite di carico /  
Friction losses diagramsDimensioni e pesi /  
Dimensions and weights

Codice Code	Misura Size	DN	PN	Peso in kg. Weight in kg.	KV m³/h	Dimensioni in mm Dimensions in mm				
						E	H	L	K	V
H222302	1/4"	8	200	0,26	0,25	25	85	50	3	63
H222303	3/8"	10	200	0,36	0,36	30	100	55	4	63
H222304	1/2"	15	200	0,53	0,47	34	115	60	6	72
H222305	3/4"	20	200	0,76	0,95	40	120	70	8	72
H222306	1"	25	200	1,18	1,1	45	138	75	9	80
H222307	1" 1/4	32	200	1,85	1,6	57	165	90	11	100
H222308	1" 1/2	40	200	2,90	4,76	67	185	100	15	120
H222309	2"	50	200	4,70	5,36	78	195	120	18	140

Componenti e materiali /  
Components and materials

1	Corpo / Body	ASTM A479-04 (316) / ASTM A182 F316
2	Coperchio / Cap	Acciaio inox / SS Aisi 316
3	Dado premistoppa / Nut	Acciaio inox / SS Aisi 316
4	Spillo / Needle	Acciaio inox A182 F316 / SS A182 F316
5	Albero / Stem	Acciaio inox A182 F316 / SS A182 F316
6	Pacco albero / Stem packing	PTFE + grafite / PTFE + graphite
7	Premistoppa / Packing nut	Acciaio inox / SS Aisi 316
8	Volantino / Handwheel	Ghisa / Cast iron
9	Dado / Nut	Acciaio inox / SS Aisi 304
10	Rondella / Washer	Acciaio inox / SS Aisi 304

Su richiesta /  
On request

Filettatura NPT / NPT thread

M2

## H2856-304

**Valvole a galleggiante /**  
Floating valves

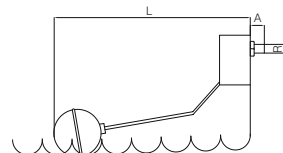
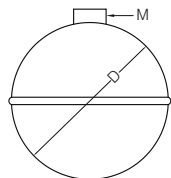
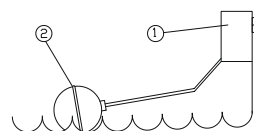

**Modello / Model**  
H2856-304

**Materiale / Material**  
Aisi 304

**Tenuta / Seal**  
SILICONE

**DN**  
10 – 32

**PN**  
10

**Caratteristiche tecniche /**  
Construction features

- **Attacco filettato gas maschio secondo /**  
Threaded end gas male according to  
ISO 228/1
- **Pressione nominale di esercizio /**  
Nominal working pressure  
10 bar
- **Temperatura di esercizio /**  
Working temperature  
-20°C – +150°C

**Componenti e materiali /**  
Components and materials

<b>1</b>	<b>Corpo / Body</b>	Acciaio inox Aisi 304 / SS Aisi 304
<b>2</b>	<b>Galleggiante /</b> Floating	Acciaio inox Aisi 304 / SS Aisi 304

**Dimensioni e pesi /**  
Dimensions and weights

**Corpo valvola / Valve body**

Codice Code	Materiale Material	Misura Size	DN	PN	Peso in kg. Weight in kg.	Dimensioni in mm Dimensions in mm	
						A	L
H285603304	Aisi 304 + Silicone	3/8"	10	10	0,10	32	304
H285604304		1/2"	15	10	0,17	35	415
H285605304		3/4"	20	10	0,31	42	485
H285606304		1"	25	10	0,37	45	581
H285607304		1" 1/4	32	10	0,47	52	581

**Galleggiante / Float**

Codice Code	Materiale Material	Misura Size	Peso in kg. Weight in kg.	Dimensioni in mm Dimensions in mm	
				D	M
H2852090304	Aisi 304	3/8"	0,07	90	M6
H2852110304		1/2"	0,10	110	M6
H2852160304		3/4", 1", 1" 1/4	0,29	160	M8

M2

# H2856

**Valvole a galleggiante /**  
Floating valves



DN80 - DN100

<b>Modello / Model</b> H2856	<b>Materiale / Material</b> Aisi 316	<b>Tenuta / Seal</b> SILICONE	<b>DN</b> 10 – 100	<b>PN</b> 10
---------------------------------	---	----------------------------------	-----------------------	-----------------

## Caratteristiche tecniche / Construction features

- **Attacco filettato gas maschio per misure da DN 10 a DN 65 secondo** / Threaded end gas male connection for sizes from DN 10 to DN 65 according to ISO 228/1
- **Attacco flangiato per DN 80 e 100 secondo** / Flanged end for DN 80 and 100 according to EN 1092 PN 10/16
- **Pressione nominale di esercizio** / Nominal working pressure 10 bar
- **Temperatura di esercizio** / Working temperature -20°C – +150°C

## Componenti e materiali / Components and materials

<b>1</b>	<b>Corpo / Body</b>	Acciaio inox Aisi 316 / SS Aisi 316
<b>2</b>	<b>Galleggiante / Floating</b>	Acciaio inox Aisi 316 / SS Aisi 316

**Su richiesta /**  
On request



**Filettatura NPT / NPT thread**

## Dimensioni e pesi / Dimensions and weights

### Corpo valvola / Valve body

Codice Code	Materiale Material	Misura Size	DN	PN	Peso in kg. Weight in kg.	Dimensioni in mm Dimensions in mm	
						A	L
H285603	Aisi 316 + Silicone	3/8"	10	10	0,23	32	300
H285604		1/2"	15	10	0,30	35	410
H285605		3/4"	20	10	0,55	42	500
H285606		1"	25	10	0,60	45	580
H285607		1" 1/4	32	10	0,80	52	580
H285608		1" 1/2	40	10	2,60	60	620
H285609		2"	50	10	2,90	70	720
H285610		2" 1/2	65	10	3,55	80	720
H285611		3"	80	10	18,95	105	1110
H285612		4"	100	10	20,50	105	1160

### Galleggiante / Float

Codice Code	Materiale Material	Misura Size	Peso in kg. Weight in kg.	Dimensioni in mm Dimensions in mm	
				D	M
H2852090	Aisi 316	3/8"	0,12	90	M6
H2852110		1/2"	0,15	110	M6
H2852160		3/4", 1", 1" 1/4	0,45	160	M8
H2852200		1" 1/2, 2", 2" 1/2	0,85	200	M12
H2852320		3"	2,80	320	M16
H2852400		4"	4,85	400	M16

M2

## H2918

## Rubinetti a sfera monoblocco /

One piece ball faucets

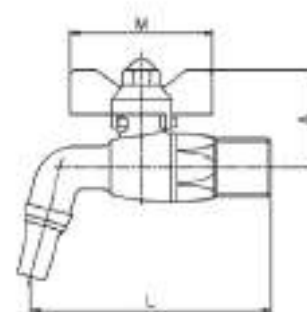
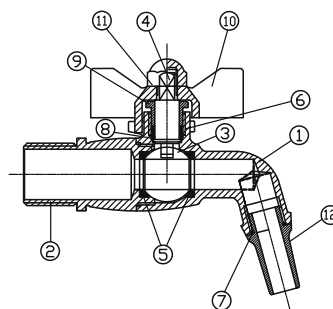

**Modello / Model**  
H2918

**Materiale / Material**  
Aisi 316

**Tenuta / Seal**  
PTFE

**DN**  
10 – 20

**PN**  
16

### Caratteristiche tecniche / Construction features

- **Attacco filettato gas maschio secondo /**  
Threaded end gas male according to  
UNI ISO 228/1
- **Pressione nominale di esercizio /**  
Nominal working pressure  
16 bar
- **Temperatura di esercizio /**  
Working temperature  
0°C – +100°C
- **Trattamento superficiale lucidatura /**  
Surface treatment polishing

### Dimensioni e pesi / Dimensions and weights

Codice Code	Misura Size	DN	PN	Peso in gr. Weight in gr.	Dimensioni in mm Dimensions in mm		
					A	L	M
H291803	3/8"	10	16	185	34	85	50
H291804	1/2"	15	16	174	34	85	50
H291805	3/4"	20	16	331	43	106	63

### Componenti e materiali / Components and materials

<b>1</b>	<b>Corpo /</b> Body	Acciaio inox / SS Aisi 316
<b>2</b>	<b>Coperchio /</b> Cap	Acciaio inox / SS Aisi 316
<b>3</b>	<b>Sfera /</b> Ball	Acciaio inox / SS Aisi 316
<b>4</b>	<b>Albero /</b> Stem	Acciaio inox / SS Aisi 316
<b>5</b>	<b>Tenuta sfera /</b> Ball seats	PTFE
<b>6</b>	<b>Anello di giuntura</b> Stem packing	PTFE
<b>7</b>	<b>Guarnizione /</b> O-ring	NBR
<b>8</b>	<b>Pacco albero /</b> Stem ring	Acciaio inox / SS Aisi 316
<b>9</b>	<b>Dado /</b> Nut	Acciaio inox / SS Aisi 316
<b>10</b>	<b>Maniglia /</b> T-Handle	Acciaio inox / SS Aisi 316
<b>11</b>	<b>Dado /</b> Nut	Acciaio inox / SS Aisi 316
<b>12</b>	<b>Bocca di uscita /</b> Outlet	Acciaio inox / SS Aisi 316

M2

## H2240

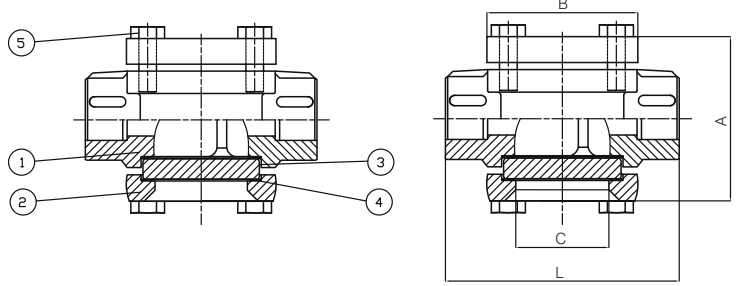
Specole visive /  
Sight glassesModello / Model  
**H2240**Materiale / Material  
Aisi 316Tenuta / Seal  
PTFEDN  
15 – 50PN  
16Caratteristiche tecniche /  
Construction features

- **Connessioni filettate femmina secondo /**  
Threaded ends female according to  
EN 10226-1
- **Pressione nominale di esercizio /**  
Nominal working pressure  
16 bar
- **Temperatura di esercizio /**  
Working temperature  
-10°C – +160°C

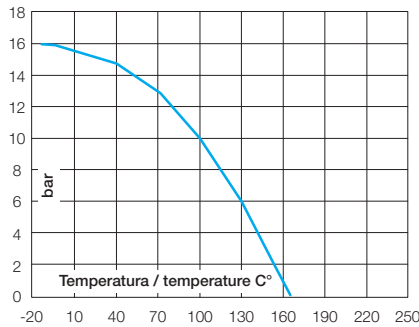
Diagramma pressione temperatura /  
Pressure temperature diagramComponenti e materiali /  
Components and materials

<b>1</b>	<b>Corpo / Body</b>	Acciaio inox / SS Aisi 316
	<b>Trattamento superficiale / Surface treatment</b>	Granigliatura / Shot blasting
<b>2</b>	<b>Coperchio / Cap</b>	Acciaio inox / SS Aisi 316
	<b>Trattamento superficiale / Surface treatment</b>	Granigliatura / Shot blasting
<b>3*</b>	<b>Vetro / Glass</b>	Vetro calciosodico temperato / Tempered soda-limeglass
<b>4*</b>	<b>Tenuta / Gasket</b>	PTFE
<b>5</b>	<b>Vite / Bolt</b>	Acciaio inox / SS Aisi 304

Dimensioni e pesi /  
Dimensions and weights

Codice Code	Misura Size	DN	PN	Peso in kg. Weight in kg.	Dimensioni in mm Dimensions in mm				Vetro Glass
					L	A	B	C	
H224004	1/2"	15	16	1,10	100	70	64	40	Ø 50 x 8
H224005	3/4"	20	16	1,05	100	70	64	40	Ø 50 x 8
H224006	1"	25	16	1,60	120	88	72	50	Ø 63 x 10
H224007	1" 1/4	32	16	1,75	120	88	72	50	Ø 63 x 10
H224008	1" 1/2	40	16	3,85	150	123	96	65	Ø 80 x 12
H224009	2"	50	16	4,00	150	123	96	65	Ø 80 x 12

\* **Ricambi disponibili / Spare parts**

M2

## H2250

**Specole visive  
flangiate /**  
Flanged sight  
glasses

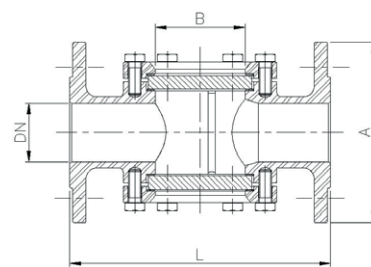
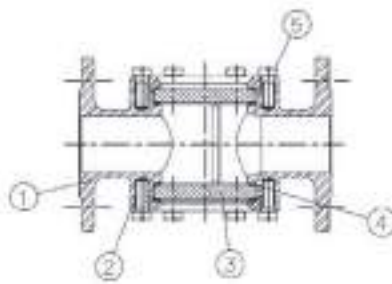

**Modello / Model**  
H2250

**Materiale / Material**  
Aisi 316

**Tenuta / Seal**  
PTFE

**DN**  
15 – 100

**PN**  
16

**Caratteristiche tecniche /**  
Construction features

- **Connessioni flangiate secondo /**  
Flanged ends according to  
UNI ISO 2278 PN 16
- **Pressione nominale di esercizio /**  
Nominal working pressure  
16 bar
- **Temperatura di esercizio /**  
Working temperature  
-10°C – +160°C

**Dimensioni e pesi /**  
Dimensions and weights

Codice Code	Misura Size	DN	PN	Peso in kg. Weight in kg.	Dimensioni in mm Dimensions in mm			
					L	A	B	Vetro Glass
H225004	1/2"	15	16	2,25	130	95	40	Ø 50 x 8
H225005	3/4"	20	16	2,80	150	105	40	Ø 50 x 8
H225006	1"	25	16	3,65	160	115	50	Ø 63 x 10
H225007	1" 1/4	32	16	5,75	180	140	50	Ø 63 x 10
H225008	1" 1/2	40	16	8,30	200	150	65	Ø 80 x 12
H225009	2"	50	16	9,80	230	165	65	Ø 80 x 12
H225010	2" 1/2	65	16	13,70	290	185	100	Ø 115 x 15
H225011	3"	80	16	16,65	310	200	100	Ø 115 x 15
H225012	4"	100	16	23,80	350	220	125	Ø 145 x 15

**Diagramma pressione temperatura /**  
Pressure temperature diagram

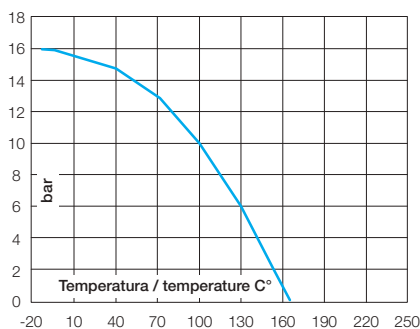

**Componenti e materiali /**  
Components and materials

<b>1</b>	<b>Corpo / Body</b>	Acciaio inox / SS 1.4408
	<b>Trattamento superficiale /</b> Surface treatment	Granigliatura / Shot blasting
<b>2</b>	<b>Coperchio / Cap</b>	Acciaio inox / SS 1.4408
	<b>Trattamento superficiale /</b> Surface treatment	Granigliatura / Shot blasting
<b>3*</b>	<b>Vetro / Glass</b>	Vetro calciosodico temperato / Tempered soda- limeglass
<b>4*</b>	<b>Tenuta / Gasket</b>	PTFE
<b>5</b>	<b>Vite / Bolt</b>	Acciaio inox / SS Aisi 304

\* **Ricambi disponibili / Spare parts**

M2

## H2272

**Riduttore di pressione** / Pressure reducing valve

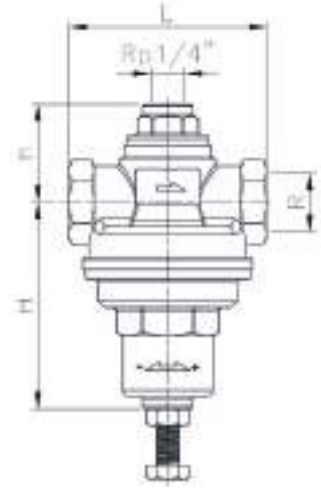
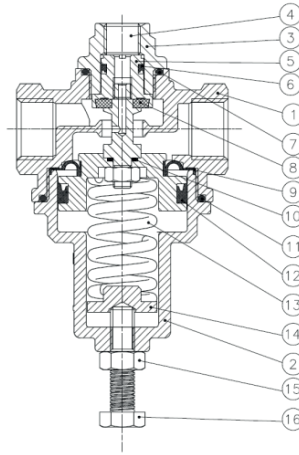

**Modello / Model**  
H2272

**Materiale / Material**  
Aisi 316

**Tenuta / Seal**  
FPM

**DN**  
15 – 25

**PN**  
25

### Caratteristiche tecniche / Construction features

- **Connessioni filettate secondo** / Threaded ends according to ISO 228/1
- **Pressione massima di esercizio** / Maximum working pressure 25 bar
- **Scala di regolazione** / Pressure adjusting range da/from 1 a/to 6 bar (tarato a/ preset 3 bar)
- **Temperatura di esercizio** / Working temperature  $-15^{\circ}\text{C} - +120^{\circ}\text{C}$
- **Connessione manometro** / Pressure gauge connection 1/4" secondo/ according to ISO 228/1

### Perdite di carico / Friction losses diagrams

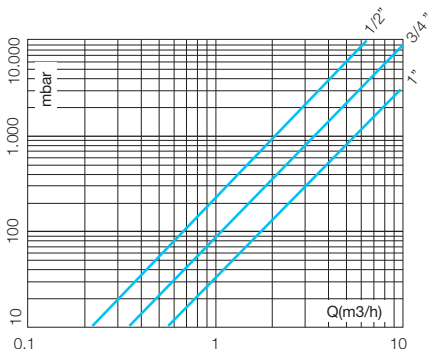

### Dimensioni e pesi / Dimensions and weights

Codice Code	Misura Size	DN	PN	Peso in gr. Weight in gr.	KV m³/h	Dimensioni in mm Dimensions in mm		
						H	h	L
H227204	1/2"	15	25	775	2,1	72	34	70
H227205	3/4"	20	25	890	3,4	75	38	85
H227206	1"	25	25	1.095	5,5	75	46	92

### Componenti e materiali / Components and materials

<b>1</b>	<b>Corpo</b> / Body	Acciaio inox / SS 1.4408
	<b>Trattamento superficiale</b> / Surface treatment	Decappaggio + sabbiatura / Pickling + Blasting
<b>2</b>	<b>Coperchio inferiore</b> / Bottom cover	Acciaio inox / SS 1.4408
	<b>Trattamento superficiale</b> / Surface treatment	Decappaggio + sabbiatura / Pickling + Blasting
<b>3</b>	<b>Coperchio superiore</b> / Top cover	Acciaio inox / SS 1.4408
	<b>Trattamento superficiale</b> / Surface treatment	Decappaggio + sabbiatura / Pickling + Blasting
<b>4</b>	<b>Tappo</b> / Plug	Acciaio inox / SS Aisi 304
<b>5</b>	<b>Pistone</b> / Piston	Acciaio inox / SS 1.4408
<b>6</b>	<b>Guarnizione a labbro</b> / U'ring	FPM
<b>7</b>	<b>Anello OR</b> / O-ring	FPM
<b>8</b>	<b>Sfera</b> / Seat	FPM
<b>9</b>	<b>Membrana</b> / Diaphragm	FPM
<b>10</b>	<b>Anello OR</b> / O-ring	FPM
<b>11</b>	<b>Anello OR</b> / O-ring	FPM
<b>12</b>	<b>Guarnizione a labbro</b> / O-ring	FPM
<b>13</b>	<b>Molla</b> / Spring	Acciaio armonico / Spring steel
	<b>Trattamento superficiale</b> / Surface treatment	Verniciatura / Painted
<b>14</b>	<b>Guida molla</b> / Spring guide	Acciaio inox / Aisi SS 1.4308
<b>15</b>	<b>Dado</b> / Nut	Acciaio inox / SS Aisi 304
<b>16</b>	<b>Vite di regolazione</b> / Adjusting screw	Acciaio inox / SS Aisi 304

M3

## H3029

Valvole a sfera in  
ottone FF PN25 /  
FF brass ball valves  
PN25

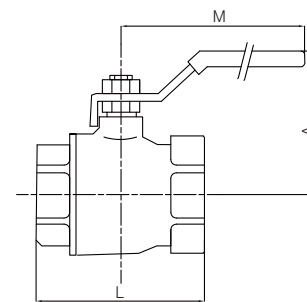
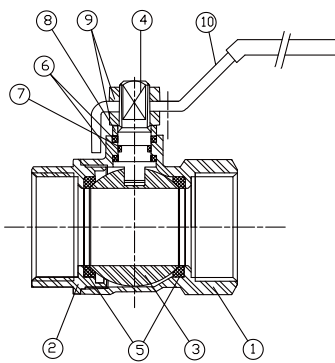

Modello / Model  
**H3029**

Materiale / Material  
Ottone / Brass

Tenuta / Seal  
PTFE

DN  
8 – 100

PN  
25

### Caratteristiche tecniche / Construction features

- **Valvole a sfera a passaggio totale /**  
Full bore ball valves  
F-F
- **Connessioni filettate gas femmina  
secondo /** Threaded ends according to  
UNI ISO 228/1
- **Pressione nominale di esercizio /**  
Nominal working pressure  
25 bar
- **Temperatura di esercizio /**  
Working temperature  
-20°C – +110°C
- **Certificazioni /** Approvals



WRAS

### Diagramma pressione temperatura / Pressure temperature diagram

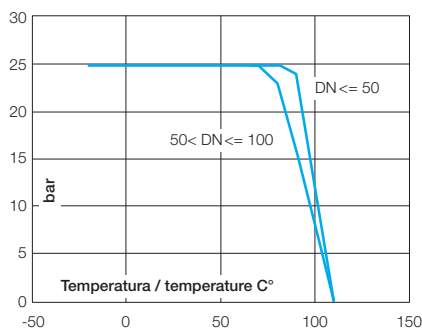

### Componenti e materiali / Components and materials

<b>1</b>	<b>Corpo / Body</b>	Ottone conforme a / Hot-forcing brass according to DIN 17660
	<b>Trattamento superficiale / Surface treatment</b>	Cromato / Chromed
<b>2</b>	<b>Coperchio / Cap</b>	Ottone / Brass
<b>3</b>	<b>Sfera / Ball</b>	Ottone / Brass
<b>4</b>	<b>Albero / Stem</b>	Ottone / Brass
<b>5</b>	<b>Tenuta sfera / Ball seats</b>	PTFE
<b>6</b>	<b>Anello di giuntura / Stem packing</b>	PTFE
<b>7</b>	<b>Guarnizione / O-ring</b>	NBR
<b>8</b>	<b>Anello di giuntura / Stem ring</b>	Ottone / Brass
<b>9</b>	<b>Dado / Nut</b>	Ottone / Brass
<b>10</b>	<b>Maniglia / Handle</b>	Acciaio / Steel

### Dimensioni e pesi / Dimensions and weights

Codice Code	Misura Size	DN	PN	Peso in gr. Weight in gr.	KV m <sup>3</sup> /h	Dimensioni in mm Dimensions in mm		
						A	L	M
H302902	1/4"	8	25	105	3,5	46	40	84
H302903	3/8"	10	25	110	5,5	46	43	84
H302904	1/2"	15	25	150	16	47	49	84
H302905	3/4"	20	25	250	30	58	56	98
H302906	1"	25	25	380	45	61	68	98
H302907	1" 1/4	32	25	595	70	74	80	126
H302908	1" 1/2	40	25	830	115	80	89	126
H302909	2"	50	25	1.330	210	96	104	158
H302910	2" 1/2	65	25	2.475	335	101	137	158
H302911	3"	80	25	3.925	405	131	158	196
H302912	4"	100	25	6.005	800	145	183	265



M3

## H3020

Valvola a sfera in ottone  
alta pressione / Brass ball  
valve high pressure

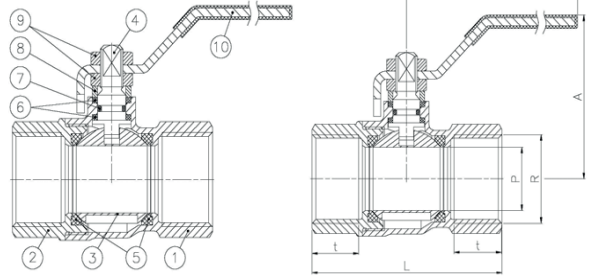

Modello / Model  
**H3020**

Materiale / Material  
Ottone / Brass

Tenuta / Seal  
PTFE

DN  
8 – 50

PN  
40

### Caratteristiche tecniche / Construction features

- **Valvole a sfera a passaggio totale /**  
Full bore ball valves  
F-F
- **Connessioni filettate gas femmina  
secondo /** Threaded ends according to  
UNI ISO 228/1
- **Pressione nominale di esercizio /**  
Nominal working pressure  
40 bar
- **Temperatura di esercizio /**  
Working temperature  
-20°C – +110°C
- **Certificazioni /** Approvals



WRAS

### Diagramma pressione temperatura / Pressure temperature diagram

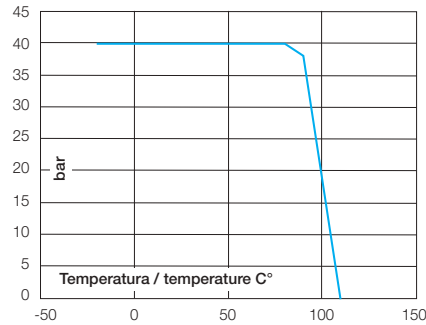

### Componenti e materiali / Components and materials

<b>1</b>	<b>Corpo /</b> Body	Ottone / Brass EN-GJS-400
	<b>Trattamento superficiale /</b> Surface treatment	Pallinato + Cromato Peened + Chromed
<b>2</b>	<b>Chiusura /</b> Cap	Ottone / Brass (CW617N)
	<b>Trattamento superficiale /</b> Surface treatment	Pallinato + Cromato Peened + Chromed
<b>3*</b>	<b>Sfera /</b> Ball	Ottone / Brass (CW617N)
	<b>Tratt. superficiale /</b> Surface treatment	Cromato / Chrome plated
<b>4</b>	<b>Albero /</b> Stem	Ottone / Brass (CW617N)
	<b>Tratt. superficiale /</b> Surface treatment	Cromato / Chrome plated
<b>5*</b>	<b>Tenute /</b> Ball seats	PTFE
<b>6</b>	<b>Premistoppa /</b> Stem packing	PTFE
<b>7</b>	<b>Anello OR /</b> O-ring	NBR
<b>8</b>	<b>Anello albero /</b> Stem ring	Ottone / Brass
	<b>Tratt. superficiale /</b> Surface treatment	Cromato / Chrome plated
<b>9</b>	<b>Dado /</b> Nut	Ottone / Brass
	<b>Tratt. superficiale /</b> Surface treatment	Cromato / Chrome plated
<b>10</b>	<b>Maniglia /</b> Handle	Acciaio / Steel

\* **Ricambi disponibili /** Spare parts

### Dimensioni e pesi / Dimensions and weights

Codice Code	Misura Size	DN	PN	P	Peso in kg. Weight in kg.	KV m³/h	Dimensioni in mm Dimensions in mm			
							A	L	M	t
H302002	1/4"	08	40	10	0,135	3,5	45	48	84	11.5
H302003	3/8"	10	40	10	0,135	5,5	45	50	84	12.5
H302004	1/2"	15	40	14	0,180	16	47	58	84	15.5
H302005	3/4"	20	40	19	0,285	30	58	65	98	16.5
H302006	1"	25	40	24	0,450	45	61	78	98	19.5
H302007	1 1/4"	32	40	30,5	0,715	70	74	88	126	20
H302008	1 1/2"	40	40	37,5	1,075	115	80	105	126	23.5
H302009	2"	50	40	47	1,645	210	91	122	158	25.5

Su richiesta /  
On request



Filettatura NPT / NPT thread

M3

## H3034

Valvole a sfera in  
ottone M-F / M-F  
brass ball valves

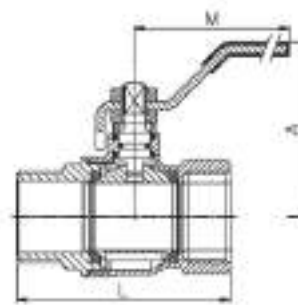
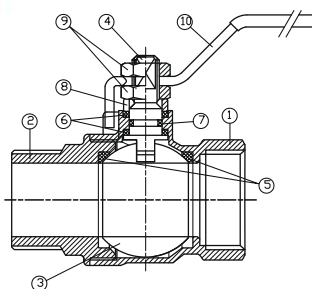

Modello / Model  
**H3034**

Materiale / Material  
Ottone / Brass

Tenuta / Seal  
PTFE

DN  
8 – 50

PN  
25

### Caratteristiche tecniche / Construction features

- **Conessioni filettate gas maschio-femmina secondo** / Threaded ends gas male-female according to UNI ISO 228/1
- **Pressione nominale di esercizio** / Nominal working pressure 25 bar
- **Temperatura di esercizio** / Working temperature -20°C – +110°C

### Diagramma pressione temperatura / Pressure temperature diagram

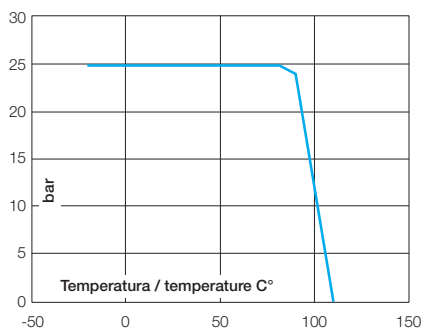

### Componenti e materiali / Components and materials

<b>1</b>	<b>Corpo</b> / Body	Ottone conforme a / Hot-forming brass according to DIN 17660
	<b>Trattamento superficiale</b> / Surface treatment	Cromato / Chromed
<b>2</b>	<b>Coperchio</b> / Cap	Ottone / Brass
<b>3</b>	<b>Sfera</b> / Ball	Ottone / Brass
<b>4</b>	<b>Albero</b> / Stem	Ottone / Brass
<b>5</b>	<b>Tenuta sfera</b> / Ball seats	PTFE
<b>6</b>	<b>Anello di giuntura</b> / Stem packing	PTFE
<b>7</b>	<b>Guarnizione</b> / O-ring	NBR
<b>8</b>	<b>Anello di giuntura</b> / Stem ring	Ottone / Brass
<b>9</b>	<b>Dado</b> / Nut	Ottone / Brass
<b>10</b>	<b>Maniglia</b> / Handle	Acciaio / Steel

### Dimensioni e pesi / Dimensions and weights

Codice Code	Misura Size	DN	PN	Peso in gr. Weight in gr.	KV m³/h	Dimensioni in mm Dimensions in mm		
						A	L	M
H303402	1/4"	8	25	115	3,5	46	48	84
H303403	3/8"	10	25	120	5,5	46	49	84
H303404	1/2"	15	25	170	16	47	55	84
H303405	3/4"	20	25	275	30	58	64	98
H303406	1"	25	25	410	45	61	76	98
H303407	1" 1/4	32	25	650	70	74	87	126
H303408	1" 1/2	40	25	875	115	80	95	126
H303409	2"	50	25	1.370	210	91	109	158

M3

# H3046

**Valvole a sfera in ottone M-F con bocchettone e con maniglia a farfalla / M-F brass ball valves with 2 pcs hose connection and with butterfly handle**

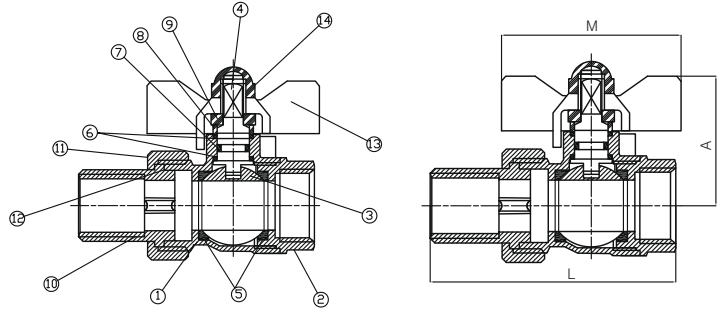

Modello / Model

H3046

Materiale / Material

Ottone / Brass

Tenuta / Seal

PTFE

DN

15 – 32

PN

25

## Caratteristiche tecniche / Construction features

- **Connessioni filettate gas maschio-femmina secondo** / Threaded ends gas male-female according to UNI ISO 228/1
- **Pressione nominale di esercizio** / Nominal working pressure 25 bar
- **Temperatura di esercizio** / Working temperature -20°C – +110°C

## Diagramma pressione temperatura / Pressure temperature diagram

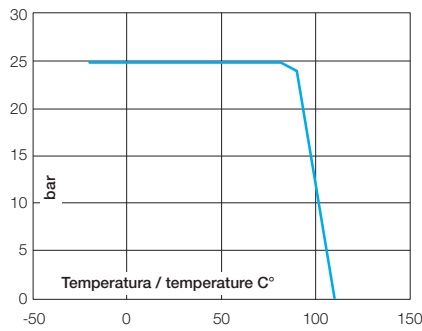

## Componenti e materiali / Components and materials

<b>1</b>	<b>Corpo</b> / Body	Ottone (cromato) conforme a / Hot-forcing brass according to DIN 17660
	<b>Trattamento superficiale</b> / Surface treatment	Cromato / Chromed
<b>2</b>	<b>Coperchio</b> / Cap	Ottone / Brass
<b>3</b>	<b>Sfera</b> / Ball	Ottone / Brass
<b>4</b>	<b>Albero</b> / Stem	Ottone / Brass
<b>5</b>	<b>Tenuta sfera</b> / Ball seats	PTFE
<b>6</b>	<b>Anello di giuntura</b> / Stem packing	PTFE
<b>7</b>	<b>Guarnizione</b> / O-ring	NBR
<b>8</b>	<b>Anello di giuntura</b> / Stem ring	Ottone / Brass
<b>9</b>	<b>Dado</b> / Nut	Ottone / Brass
<b>10</b>	<b>Connessione</b> / Hose connection	Ottone / Brass
<b>11</b>	<b>Dado</b> / Nut	Ottone / Brass
<b>12</b>	<b>Guarnizione</b> / O-ring	NBR
<b>13</b>	<b>Maniglia</b> / T-Handle	Alluminio / Aluminium
<b>14</b>	<b>Dado</b> / Nut	Ottone / Brass

## Dimensioni e pesi / Dimensions and weights

Codice Code	Misura Size	DN	PN	Peso in gr. Weight in gr.	KV m <sup>3</sup> /h	Dimensioni in mm Dimensions in mm		
						A	L	M
H304604	1/2"	15	25	185	16	36	69	50
H304605	3/4"	20	25	305	30	44	76	62
H304606	1"	25	25	490	45	48	92	62
H304607	1"1/4	32	25	715	70	57	106	78

M3

## H3046 / ML

**Valvole a sfera in ottone M-F con bocchettone e con maniglia a leva / M-F brass ball valves with 2 pcs hose connection and with straight handle**

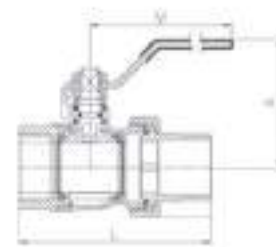
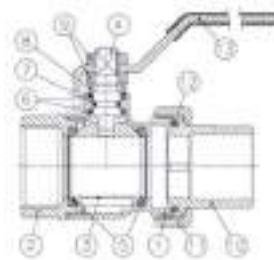

**Modello / Model**  
H3046 / ML

**Materiale / Material**  
Ottone / Brass

**Tenuta / Seal**  
PTFE

**DN**  
15 – 50

**PN**  
25

### Caratteristiche tecniche / Construction features

- **Connessioni filettate gas maschio-femmina secondo / Threaded ends gas male-female according to UNI ISO 228/1**
- **Pressione nominale di esercizio / Nominal working pressure 25 bar**
- **Temperatura di esercizio / Working temperature -20°C – +110°C**

### Diagramma pressione temperatura / Pressure temperature diagram

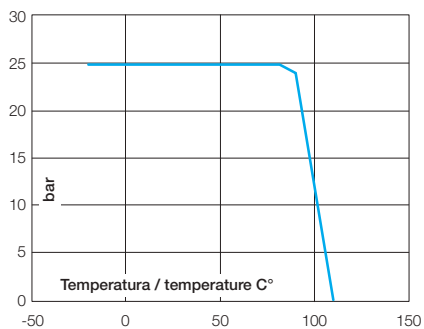

### Componenti e materiali / Components and materials

<b>1</b>	<b>Corpo / Body</b>	Ottone conforme a / Hot-forcing brass according to DIN 17660
	<b>Tattamento superficiale / Surface treatment</b>	Cromato / Chromed
<b>2</b>	<b>Coperchio / Cap</b>	Ottone / Brass
<b>3</b>	<b>Sfera / Ball</b>	Ottone / Brass
<b>4</b>	<b>Albero / Stem</b>	Ottone / Brass
<b>5</b>	<b>Tenuta sfera / Ball seats</b>	PTFE
<b>6</b>	<b>Anello di giuntura / Stem packing</b>	PTFE
<b>7</b>	<b>Guarnizione / O-ring</b>	NBR
<b>8</b>	<b>Anello di giuntura / Stem ring</b>	Ottone / Brass
<b>9</b>	<b>Dado / Nut</b>	Ottone / Brass
<b>10</b>	<b>Connessione / Hose connection</b>	Ottone / Brass
<b>11</b>	<b>Dado / Nut</b>	Ottone / Brass
<b>12</b>	<b>Guarnizione / O-ring</b>	NBR
<b>13</b>	<b>Maniglia / T-Handle</b>	Alluminio / Aluminium

### Dimensioni e pesi / Dimensions and weights

Codice Code	Direzione leva Handle side	Misura Size	DN	PN	Peso in gr. Weight in gr.	KV m³/h	Dimensioni in mm Dimensions in mm		
							A	L	M
H304604ML	Lato maschio / Male side	1/2"	15	25	205	16	47	69	84
H304605ML		3/4"	20	25	340	30	58	77	98
H304606ML		1"	25	25	525	45	61	92,5	98
H304607ML	Lato femmina / Female side	1" 1/4	32	25	785	70	74	105,5	126
H304608ML		1" 1/2	40	25	1.145	115	80	119	126
H304609ML		2"	50	25	1.710	210	91	139	158

M3

# H3023

**Valvole a sfera in ottone con attacco diretto attuatore** / Brass ball valves for direct actuator installation

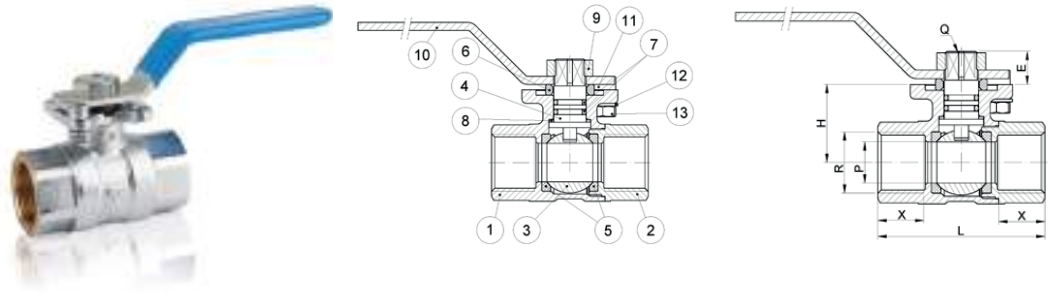

**Modello / Model**  
H3023

**Materiale / Material**  
Ottone / Brass

**Tenuta / Seal**  
PTFE

**DN**  
15 – 50

**PN**  
40

## Caratteristiche tecniche / Construction features

- **Montaggio diretto attuatore secondo /** Direct actuator connection according to ISO 5211
- **Connessioni filettate gas secondo /** Threaded ends gas according to ISO 228/1
- **Pressione nominale di esercizio /** Nominal working pressure 40 bar
- **Temperatura di esercizio /** Working temperature -20°C – +110°C

## Diagramma pressione temperatura / Pressure temperature diagram

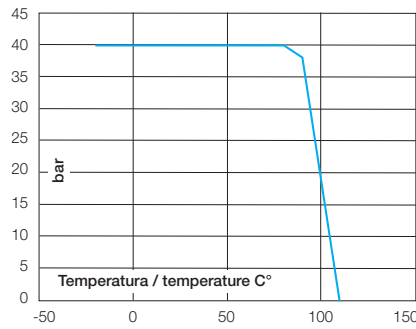

## Componenti e materiali / Components and materials

<b>1</b>	<b>Corpo / Body</b>	Ottone cromato / Chromed brass
<b>2</b>	<b>Chiusura / Cap</b>	Ottone cromato / Chromed brass
<b>3</b>	<b>Sfera / Ball</b>	Ottone cromato / Chromed brass
<b>4</b>	<b>Albero / Stem</b>	Ottone cromato / Chromed brass
<b>5</b>	<b>Tenuta sfera / Ball seats</b>	PTFE
<b>6</b>	<b>Anello / Ring</b>	Nylon
<b>7</b>	<b>Anello OR / O-ring</b>	NBR
<b>8</b>	<b>Anello / Ring</b>	PTFE
<b>9</b>	<b>Dado / Nut</b>	Acciaio zincato / Zinc plated steel
<b>10</b>	<b>Maniglia / Handle</b>	Acciaio Dacromet / Dacromet steel
<b>11</b>	<b>Vite Allen / Allen screw</b>	Acciaio zincato / Zinc plated steel
<b>12</b>	<b>Rondella / Grower washer</b>	Acciaio zincato / Zinc plated steel
<b>13</b>	<b>Dado / Nut</b>	Acciaio zincato / Zinc plated steel

## Dimensioni e pesi / Dimensions and weights

Codice Code	Misura Size	DN	PN	Peso in gr. Weight in gr.	KV m³/h	Dimensioni in mm Dimensions in mm						
						P	X	L	H	E	ISO 5211	Q
H302304	1/2"	15	40	274	16	14,3	15	58	27	11,5	F03	9
H302305	3/4"	20	40	376	30	19	16	65	32	11	F03	9
H302306	1"	25	40	564	45	23,8	19,5	78	35	11	F04	9
H302307	1" 1/4	32	40	927	70	30	19,5	88	43,3	13,5	F05	11
H302308	1" 1/2	40	40	1.254	115	37,3	24,6	105	48,8	13,5	F05	11
H302309	2"	50	40	1.886	210	46,5	26,5	122	60	13,8	F05	11

M3

## H3035

**Valvole a sfera in ottone con maniglia a farfalla** / Brass ball valves with butterfly handle

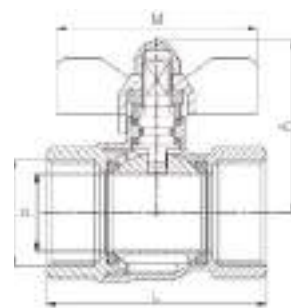
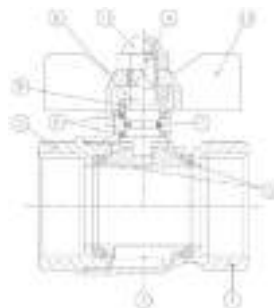

**Modello / Model**  
H3035

**Materiale / Material**  
Ottone / Brass

**Tenuta / Seal**  
PTFE

**DN**  
8 – 25

**PN**  
25

**Caratteristiche tecniche /**  
Construction features

- **Connessioni filettate gas secondo /**  
Threaded ends gas according to  
UNI ISO 228/1
- **Pressione nominale di esercizio /**  
Nominal working pressure  
25 bar
- **Temperatura di esercizio /**  
Working temperature  
-20°C – +110°C

**Diagramma pressione temperatura /**  
Pressure temperature diagram

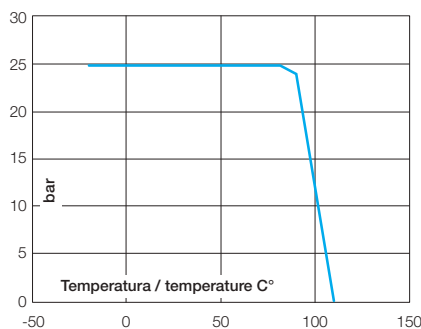

**Componenti e materiali /**  
Components and materials

1	<b>Corpo / Body</b>	Ottone cromato / Chromed brass
2	<b>Coperchio / Cap</b>	Ottone cromato / Chromed brass
3	<b>Sfera / Ball</b>	Ottone cromato / Chromed brass
4	<b>Albero / Stem</b>	Ottone cromato / Chromed brass
5	<b>Tenuta sfera /</b> Ball seats	PTFE
6	<b>Anello albero /</b> Stem packing	PTFE
7	<b>Guarnizione /</b> O-ring	NBR
8	<b>Guarnizione</b> albero Stem ring	Ottone cromato / Chromed brass
9	<b>Dado / Nut</b>	Ottone cromato / Chromed brass
10	<b>Maniglia /</b> T-Handle	Alluminio verniciato Painted aluminum
11	<b>Dado / Nut</b>	Ottone cromato / Chromed brass

**Dimensioni e pesi /**  
Dimensions and weights

Codice Code	Misura Size	DN	PN	Peso in gr. Weight in gr.	KV m³/h	Dimensioni in mm Dimensions in mm			
						P	A	L	M
H303502	1/4"	8	25	90	3,5	10	38	40	50
H303503	3/8"	10	25	100	5,5	10	38	43	50
H303504	1/2"	15	25	145	16	14	40	49	50
H303505	3/4"	20	25	240	30	19	50	56	62
H303506	1"	25	25	360	45	24	53	68	62

M3

# H3036

**Valvole a sfera in ottone con maniglia a farfalla** / Brass ball valves with butterfly handle

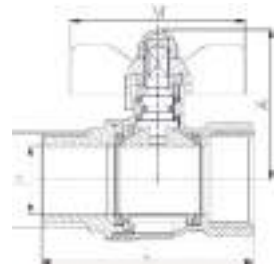
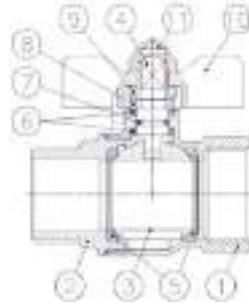

**Modello / Model**  
H3036

**Materiale / Material**  
Ottone / Brass

**Tenuta / Seal**  
PTFE

**DN**  
8 – 25

**PN**  
25

## Caratteristiche tecniche / Construction features

- **Connessioni filettate gas secondo** / Threaded ends gas according to UNI ISO 228/1
- **Pressione nominale di esercizio** / Nominal working pressure 25 bar
- **Temperatura di esercizio** / Working temperature -20°C – +110°C

## Diagramma pressione temperatura / Pressure temperature diagram

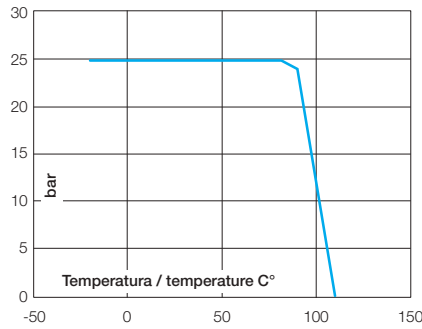

## Componenti e materiali / Components and materials

1	<b>Corpo</b> / Body	Ottone cromato / Chromed brass
2	<b>Coperchio</b> / Cap	Ottone cromato / Chromed brass
3	<b>Sfera</b> / Ball	Ottone cromato / Chromed brass
4	<b>Albero</b> / Stem	Ottone cromato / Chromed brass
5	<b>Tenuta sfera</b> / Ball seats	PTFE
6	<b>Anello albero</b> / Stem packing	PTFE
7	<b>Guarnizione</b> / O-ring	NBR
8	<b>Guarnizione albero</b> / Stem ring	Ottone cromato / Chromed brass
9	<b>Dado</b> / Nut	Ottone cromato / Chromed brass
10	<b>Maniglia</b> / T-Handle	Alluminio verniciato / Painted aluminum
11	<b>Dado</b> / Nut	Ottone cromato / Chromed brass

## Dimensioni e pesi / Dimensions and weights

Codice Code	Misura Size	DN	PN	Peso in gr. Weight in gr.	KV m³/h	Dimensioni in mm Dimensions in mm			
						P	A	L	M
H303602	1/4"	8	25	100	3,5	10	38	48	50
H303603	3/8"	10	25	105	5,5	10	38	49	50
H303604	1/2"	15	25	150	16	14	40	56	50
H303605	3/4"	20	25	250	30	19	50	64	62
H303606	1"	25	25	380	45	24	53	76	62

M3

## H3096

Mini valvole a sfera  
in ottone / Brass mini  
ball valves

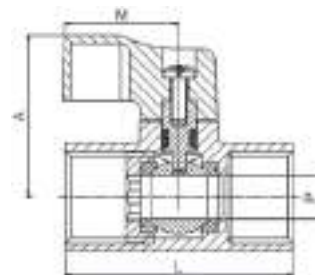
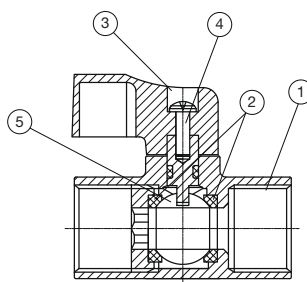

Modello / Model  
**H3096**

Materiale / Material  
Ottone / Brass

Tenuta / Seal  
PTFE

DN  
6 – 20

PN  
16

### Caratteristiche tecniche / Construction features

- **Valvole a sfera monoblocco a passaggio ridotto** / One piece reduced bore ball valves
- **Connessioni filettate gas secondo** / Threaded ends gas according to UNI ISO 228/1
- **Pressione nominale di esercizio** / Nominal working pressure 16 bar
- **Temperatura di esercizio** / Working temperature -20°C – +110°C

### Diagramma pressione temperatura / Pressure temperature diagram

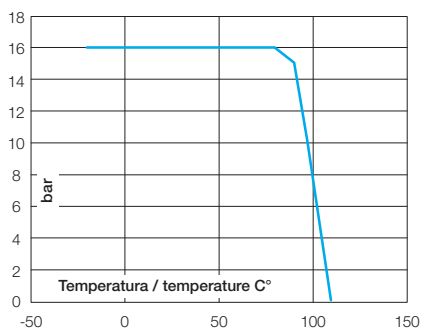

### Componenti e materiali / Components and materials

<b>1</b>	<b>Corpo</b> / Body	Ottone cromato / Chromed brass
<b>2</b>	<b>Tenuta sfera</b> / Seat ball	PTFE
<b>3</b>	<b>Maniglia</b> / T-Handle	Alluminio / Aluminum
<b>4</b>	<b>Albero</b> / Stem	Ottone cromato / Chromed brass
<b>5</b>	<b>Sfera</b> / Ball	Ottone cromato / Chromed brass

### Dimensioni e pesi / Dimensions and weights

Codice Code	Misura Size	DN	PN	Peso in gr. Weight in gr.	KV m <sup>3</sup> /h	Dimensioni in mm Dimensions in mm			
						P	A	L	M
H309601	1/8"	6	16	50	2,8	6,5	28	37	22
H309602	1/4"	8	16	50	3,5	6,5	28	39	22
H309603	3/8"	10	16	75	5	8	30	42	22
H309604	1/2"	15	16	105	8	10	33	46	22
H309605	3/4"	20	16	170	13	12,5	36	55	22



M3

## H3097

Mini valvole a sfera  
in ottone / Brass mini  
ball valves

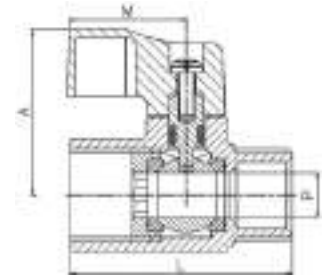
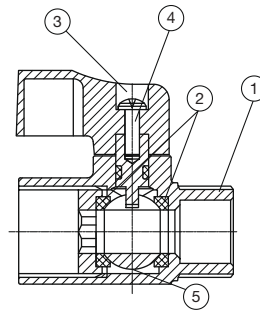

Modello / Model  
**H3097**

Materiale / Material  
Ottone / Brass

Tenuta / Seal  
PTFE

DN  
6 – 20

PN  
16

### Caratteristiche tecniche / Construction features

- **Valvole a sfera monoblocco a passaggio ridotto** / One piece reduced bore ball valves
- **Connessioni filettate gas secondo** / Threaded ends gas according to UNI ISO 228/1
- **Pressione nominale di esercizio** / Nominal working pressure 16 bar
- **Temperatura di esercizio** / Working temperature -20°C – +110°C

### Componenti e materiali / Components and materials

<b>1</b>	<b>Corpo</b> / Body	Ottone cromato / Chromed brass
<b>2</b>	<b>Tenuta sfera</b> / Seat ball	PTFE
<b>3</b>	<b>Maniglia</b> / T-Handle	Alluminio / Aluminum
<b>4</b>	<b>Albero</b> / Stem	Ottone cromato / Chromed brass
<b>5</b>	<b>Sfera</b> / Ball	Ottone cromato / Chromed brass

### Diagramma pressione temperatura / Pressure temperature diagram

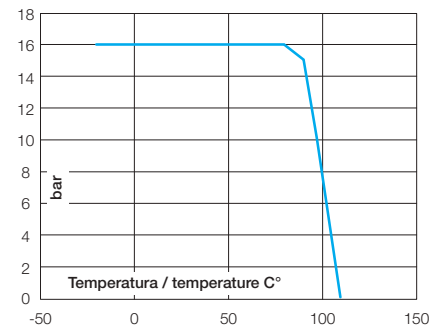

### Dimensioni e pesi / Dimensions and weights

Codice Code	Misura Size	DN	PN	Peso in gr. Weight in gr.	KV m³/h	Dimensioni in mm Dimensions in mm			
						P	A	L	M
H309701	1/8"	6	16	45	2,8	6,5	28	36	22
H309702	1/4"	8	16	45	3,5	6,5	28	37	22
H309703	3/8"	10	16	65	5	8	30	40	22
H309704	1/2"	15	16	100	8	10	33	44	22
H309705	3/4"	20	16	160	13	12,5	36	52	22

M3

## H3272E - H3282E

Valvole a sfera a  
3 vie in ottone /  
Brass 3 ways ball  
valves

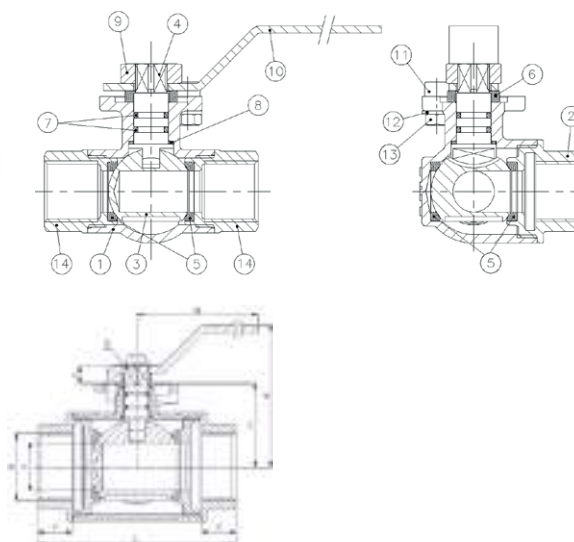

Modello / Model

H3272E - H3282E

Materiale / Material

Ottone / Brass

Tenuta / Seal

PTFE

DN

15 - 25

PN

25

### Caratteristiche tecniche / Construction features

- **Montaggio diretto attuatore secondo /**  
Direct actuator connection according to  
ISO 5211
- **Connessioni filettate gas femmina-  
femmina secondo /** Threaded ends gas  
female-female according to  
UNI ISO 228/1
- **Otturatore sferico: a 2/3 vie ad L (H3272E)  
o T (H3282E), montato su 4 sedi di PTFE  
puro /** Spherical seal: 2/3 ways L (H3272E) or  
T (H3282E) shape assembled on 4 pure PTFE  
seats
- **Temperatura di esercizio /**  
Working temperature  
-10°C - +150°C

### Diagramma pressione temperatura / Pressure temperature diagram

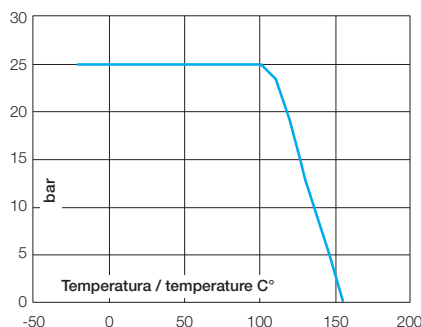

### Componenti e materiali / Components and materials

1	Corpo / Body	Ottone nichelato / Nickel plated brass
2	Coperchio / Cap	Ottone nichelato / Nickel plated brass
3	Sfera / Ball	Ottone cromato / Chromed brass
4	Albero / Stem	Ottone nichelato / Nickel plated brass
5	Sede sfera / Ball seats	PTFE
6	Anello / Ring	Nylon
7	O-ring / O-ring	EPDM
8	Anello / Ring	PTFE
9	Dado / Nut	Acciaio Zincato / Zinc plated steel
10	Maniglia / Handle	Acciaio Dacromet / Dacromet Steel
11	Vite Allen / Allen screw	Acciaio Zincato / Zinc plated steel
12	Rondella Grower Grower washer	Acciaio Zincato / Zinc plated steel
13	Dado / Nut	Acciaio Zincato / Zinc plated steel
14	Coperchio / Cap	Ottone nichelato / Nickel plated brass

### Dimensioni e pesi / Dimensions and weights

Codice Code	Versione Type	Misura Size	DN	PN	Peso in gr. Weight in gr.	KV m³/h	Dimensioni in mm Dimensions in mm									ISO 5211
							R	P	X	L	A	M	H	E	Q	
H3272E04	L	1/2"	15	25	443	15	1/2"	15	18	74	58	104	33	11,5	9	F03
H3272E05		3/4"	20	25	682	31	3/4"	20	20	85	63	112	38	12,5	9	F04
H3272E06		1"	25	25	1.012	39	1"	25	22	97	68	112	42,5	12,5	9	F04
H3282E04	T	1/2"	15	25	440	15	1/2"	15	18	74	58	104	33	11,5	9	F03
H3282E05		3/4"	20	25	675	31	3/4"	20	20	85	63	112	38	12,5	9	F04
H3282E06		1"	25	25	1.000	39	1"	25	22	97	68	112	42,5	12,5	9	F04

M3

## H3220

Valvole a saracinesca  
in ottone / Brass gate  
valves

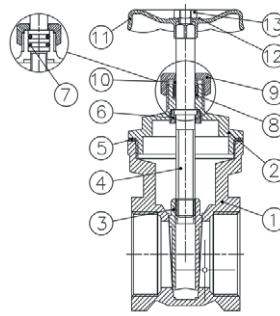

Modello / Model  
**H3220**

Materiale / Material  
Ottone / Brass

Tenuta / Seal  
Metallica / Metallic

DN  
15 – 100

PN  
16

Caratteristiche tecniche /  
Construction features

- **Connessioni filettate gas secondo /**  
Threaded ends gas according to  
UNI ISO 228/1
- **Pressione nominale di esercizio /**  
Nominal working pressure  
16 bar
- **Temperatura di esercizio /**  
Working temperature  
-15°C – +105°C Aria / Air  
0°C – +110°C Acqua / Water

Diagramma pressione temperatura /  
Pressure temperature diagram

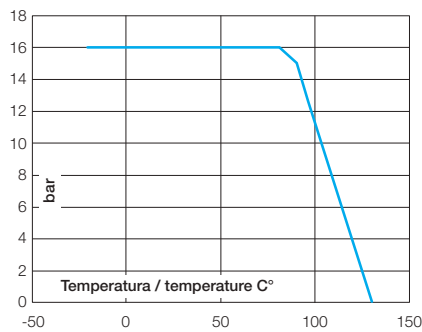

Componenti e materiali /  
Components and materials

1	<b>Corpo / Body</b>	Ottone / Brass (CW617N)
2	<b>Coperchio / Bonnet</b>	Ottone / Brass (CW617N)
3	<b>Saracinesca / Gate</b>	Ottone / Brass (CW617N)
4	<b>Albero / Stem</b>	Ottone / Brass (CW617N)
5	<b>Guarnizione chiusura / Bonnet joint</b>	PTFE
6	<b>Dado di chiusura / Lock nut</b>	Ottone / Brass
7	<b>Guarnizioni albero / Stem sealing</b>	NBR
8	<b>Pacco albero / Stem packing</b>	PTFE
9	<b>Dado di giuntura / Packing nut</b>	Ottone / Brass
10	<b>Anello premi stoppa / Packing ring</b>	Ottone / Brass
11	<b>Volantino / Wheel</b>	Acciaio / Steel
12	<b>Rondella / Washer</b>	Alluminio / Aluminum
13	<b>Dado / Nut</b>	Acciaio / Steel

Dimensioni e pesi /  
Dimensions and weights

Codice Code	Misura Size	DN	PN	Peso in gr. Weight in gr.	KV m³/h	Dimensioni in mm Dimensions in mm			
						P	A	L	M
H322004	1/2"	15	16	158	6	13	62	36,8	51
H322005	3/4"	20	16	206	17	15	66	42,5	55,8
H322006	1"	25	16	291	28	19	73	45,8	60
H322007	1" 1/4	32	16	436	42	27	91	50,8	60,6
H322008	1" 1/2	40	16	602	78	33	98	54	70,8
H322009	2"	50	16	1.056	110	42	127	62,8	92
H322010	2" 1/2	65	16	1.890	400	57	160	68	100
H322011	3"	80	16	2.526	520	60	190	83	110
H322012	4"	100	16	4.518	750	91	238	92	132

M3

# FLOW-THRU

**Valvola di ricircolo per vasi di espansione a membrana / Recirculation valve for diaphragm pressure vessels.**

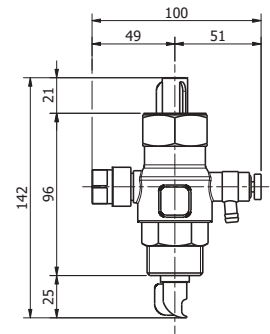
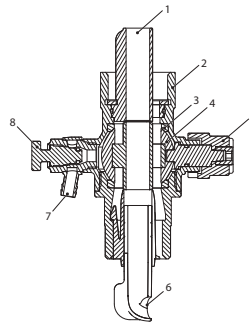

**Dimensioni in mm**  
Dimensions in mm

**Modello / Model**  
**FLOW-THRU**

**Materiale / Material**  
Ottone / Brass / POM

**Tenuta / Seal**  
PTFE

**DN**  
25

**PN**  
10

## Caratteristiche tecniche / Construction features

- **Il costante ricircolo evita i ristagni di acqua e previene la proliferazione batterica come ad esempio la legionella.** / The constant flushing activity assists in eliminating the risk of stagnant water and reducing the possibility of waterborne bacteria such as legionella.
- **Conessioni filettate gas secondo /** Threaded ends gas according to UNI ISO 228/1
- **Pressione nominale di esercizio /** Nominal working pressure 10 bar
- **Temperatura di esercizio /** Working temperature 0°C – +90°C
- **Trattamento superficiale nichelatura /** Surface treatment nickel plating
- **Certificazioni /** Approvals



WRAS



ACS

## Dimensioni / Dimensions

Codice Code	Misura Size
IFP-100B	1"

## Componenti e materiali / Components and materials

<b>1</b>	<b>Stelo guida flusso /</b> Flow guiding shaft	POM
<b>2</b>	<b>Corpo valvola /</b> Valve body	Ottone cromato / Chromed brass
<b>3</b>	<b>Guarnizione sfera /</b> Ball seat	PTFE
<b>4</b>	<b>Sfera /</b> Ball	Ottone cromato / Chromed brass
<b>5</b>	<b>Comando chiusura valvola /</b> Valve closing point	Alluminio / Aluminium
<b>6</b>	<b>Bocca entrata flusso /</b> Flow inlet	POM
<b>7</b>	<b>Attacco per prelievi /</b> Sampling connector	Plastica / Plastic
<b>8</b>	<b>Vite apertura prelievo /</b> Sample point screw	Ottone / Brass
	<b>Guarnizioni /</b> Gaskets	EPDM

## Principio di funzionamento / Operating principle

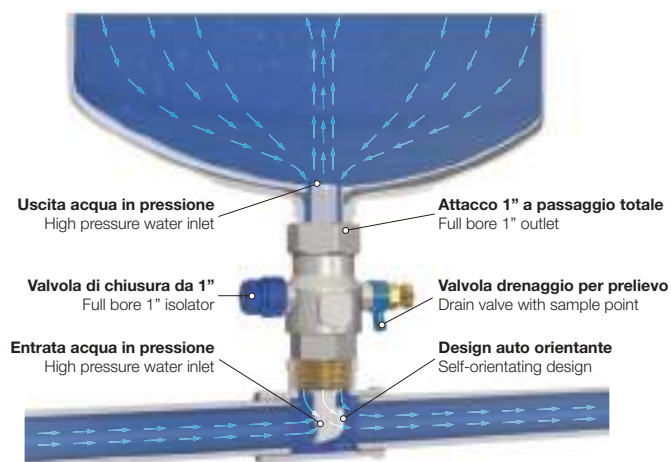

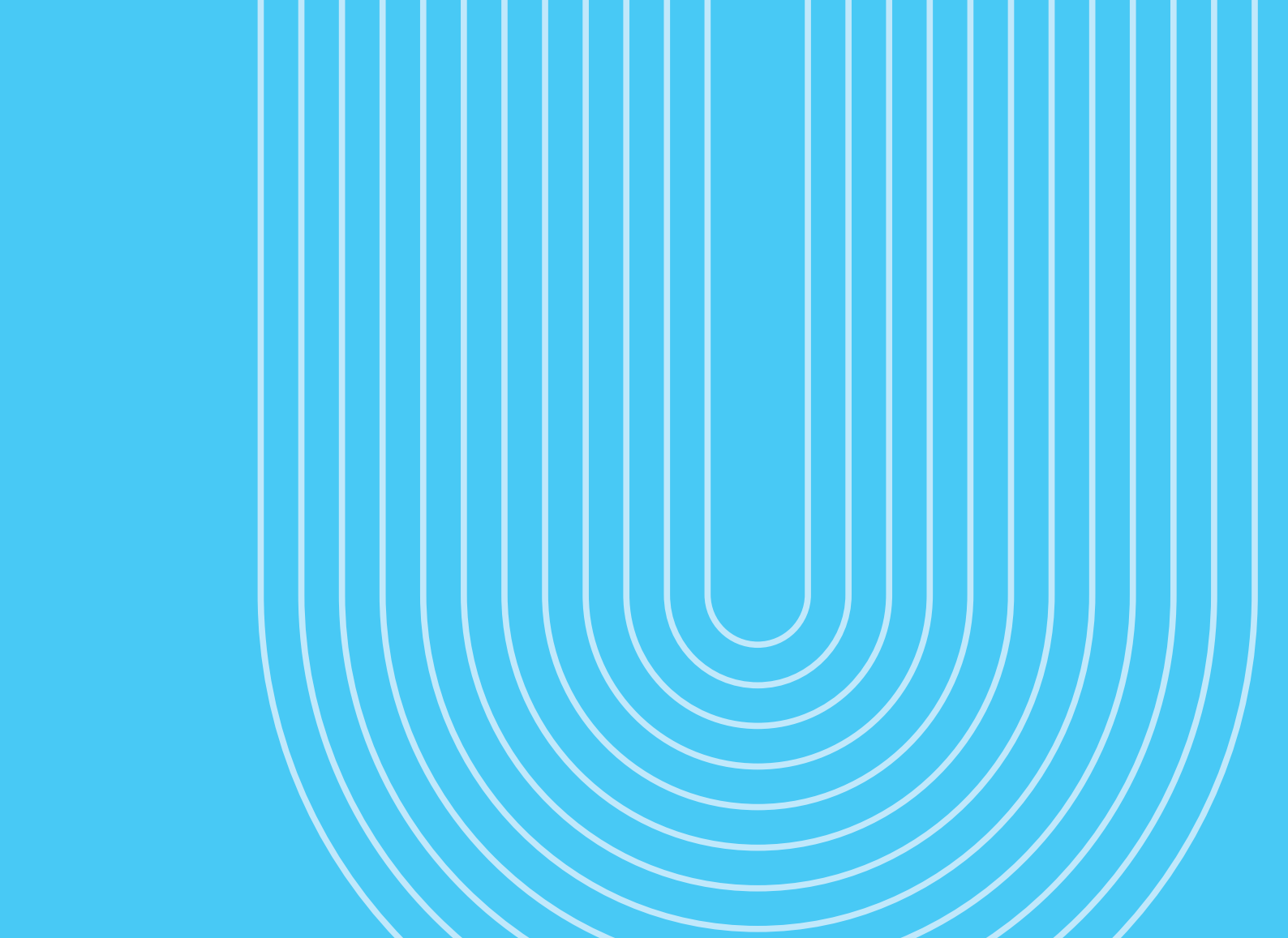

## Valvole motorizzate Actuated valves

- **Le valvole motorizzate sono valvole di intercettazione, a sfera e a farfalla, dotate di un'apparecchiatura che consente la chiusura e apertura a distanza mediante un attuatore. L'attuatore può essere a funzionamento elettrico o pneumatico.** / Motorised valves are ball and butterfly shut-off valves, with an apparatus that permits remote closing and opening by way of an electric or pneumatic actuator.
- **L'attuatore pneumatico trasmette il moto alla valvola utilizzando come fluido motore aria compressa. Gli attuatori pneumatici possono essere a doppio effetto o a semplice effetto: nel primo caso sia l'apertura che la chiusura è effettuata dall'aria, nell'altro il ritorno è comandato da una molla.** / The pneumatic actuator transmits movement to the valve using compressed air as the movement source. Pneumatic actuators can be double or single effect: in the first case it is the air that opens and closes, while in the other case closing is controlled by a spring.

M10

## 5800 GNP

**Attuatore pneumatico a singolo e doppio effetto** / Pneumatic actuator spring return and double acting



**Modello / Model**  
5800 GNP

**Materiale / Material**  
Al 6005-T5

**Temperatura di esercizio / Working temperature**  
-20° – +80° C

**Pressione aria / Air pressure**  
min. 2 – max 8 bar

### Caratteristiche tecniche / Construction features

- **Fluido di lavoro**  
Aria secca o lubrificata, gas non corrosivi /  
Operating media  
Dry or lubricated air, non-corrosive gases
- **Pressione di alimentazione dell'aria**  
Doppio effetto: 2-8 bar  
Singolo effetto: 2-8 bar /  
Air supply pressure  
Double acting: 2-8 bar  
Spring return: 2-8 bar
- **Temperatura di esercizio /**  
Working temperature  
Standard: -20°C – +80°C
- **Corsa di regolazione**  
Campo di regolazione di ±5°  
per una rotazione di 90° /  
Travel adjustment  
Have adjustment range of ±5°  
for the rotation at 90°
- **Lubrificazione: nessun lubrificante**  
**necessario in condizioni di funzionamento**  
**normali** / Lubrication: under normal operating  
conditions, no lubricant is needed
- **Applicazione: in ambienti chiusi o**  
**all'esterno** / Application: either indoor or  
outdoor
- **La pressione massima**  
**di ingresso deve essere di /**  
The maximum input pressure is  
8 bar

### Componenti e materiali / Components and materials

1	<b>Anello Seeger /</b> Spring clip	Acciaio inox / SS Aisi 304
2	<b>Alloggiamento</b> <b>indicatore pos. /</b> Housing indicator	PC+ABS / Plastic
3	<b>Indicatore pos. /</b> Indicator	PC+ABS / Plastic
4	<b>Corpo /</b> Body	Al 6005-T5 / Extruded aluminium alloy
	<b>Protezione /</b> Protection	Anodizzazione + verniciatura / Anodized + painted
5*	<b>Guida pistone /</b> Guide piston	Tecnopolimero / POM
6*	<b>O-ring superiore /</b> O-ring (pinion top)	NBR
7*	<b>Anello superiore /</b> Washer (pinion top)	Tecnopolimero / POM
8*	<b>Separatore /</b> Bearing (pinion top)	Tecnopolimero / POM
9	<b>Camma /</b> Cam	Acciaio / Alloy steel
10	<b>Pignone /</b> Pinion	Acciaio / Alloy steel
	<b>Protezione /</b> Protection	Nichelatura / Nickel plated
11*	<b>Anello inferiore /</b> Bearing (pinion bottom)	Tecnopolimero / POM
12*	<b>O-ring inferiore /</b> O-ring (pinion bottom)	NBR
13	<b>Molla /</b> Spring	Acciaio inox / SS Aisi 301
14*	<b>Anello pistone /</b> Ring (Piston)	Tecnopolimero / POM
15*	<b>O-ring pistone /</b> O-ring (Piston)	NBR
16	<b>Pistone /</b> Piston	Al. A380.1 / Cast aluminium
	<b>Protezione /</b> Protection	Anodizzazione + verniciatura / Anodized + painted

17*	<b>Tappo /</b> Plug	NBR
18*	<b>O-ring /</b> O-ring	NBR
19	<b>Dado /</b> Adjust Nut	Acciaio inox / SS Aisi 304
20	<b>Prigioniero /</b> Adjust screw	Acciaio inox / SS Aisi 304
21	<b>Vite di arresto /</b> Stop screw	Acciaio inox / SS Aisi 304
22	<b>Dado di arresto /</b> Nut (stop screw)	Acciaio inox / SS Aisi 304
23*	<b>O-ring chiusura /</b> O-ring (End cap)	NBR
24	<b>Coperchio destro</b> End cap right	Al. A380.1 / Cast aluminium
	<b>Protezione /</b> Protection	Anodizzazione + verniciatura / Anodized + painted
25	<b>Coperchio sinistro</b> End cap left	Al. A380.1 / Cast aluminium
	<b>Protezione /</b> Protection	Anodizzazione + verniciatura / Anodized + painted
26	<b>Vite chiusura /</b> Cap screw	Acciaio inox / SS Aisi 304
27*	<b>Anello Seeger /</b> Spring clip	Acciaio inox / SS Aisi 304
28*	<b>Rondella /</b> Washer	Acciaio inox / SS Aisi 304
29*	<b>Separatore /</b> Ring	Tecnopolimero / POM

\* **Ricambi disponibili /** Spare parts

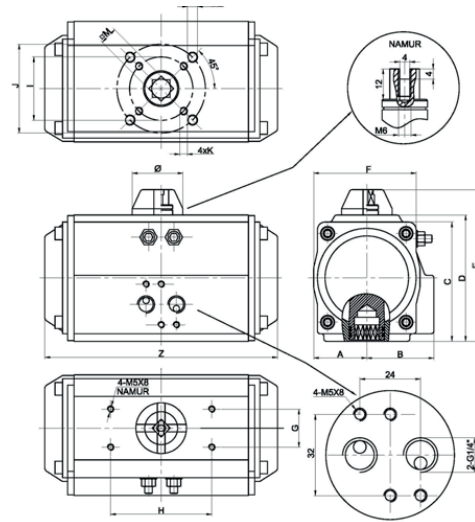
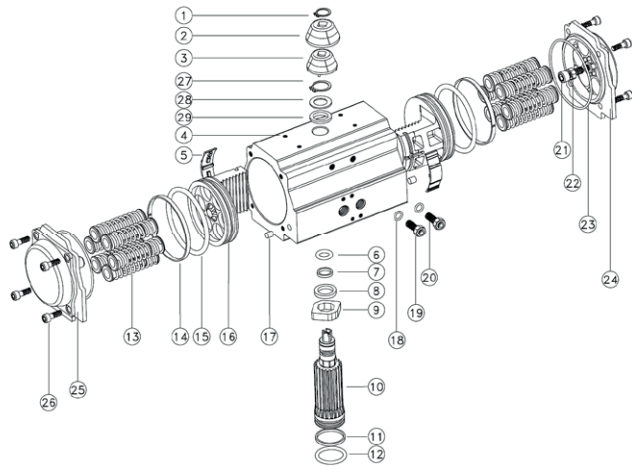

## Dimensioni / Dimensions

Modelli Model	A	B	C	D	E	F	G	H	I	J	K	L	M	N	Z	Ø	Air Connection NAMUR
GNP14	28.5	36.5	60	-	90	52	30	80	(Ø36)*	(Ø42)*	M5	M5	11	14	122	Ø 55	G1/4"
GNP24	30	41.5	65.5	72	102	65	30	80	(Ø36)*	(Ø42)*	M5	M5	11	14	147	Ø 55	G1/4"
GNP44	36	47	81	87.5	117.5	72	30	80	(Ø42)*	(Ø50/Ø70)*	M5	M6/M8	14	18	168	Ø 55	G1/4"
GNP60	42	53	94	99.5	129.5	81	30	80	Ø50	Ø70	M6	M8	14	18	184	Ø 55	G1/4"
GNP94	46	57	98.5	108.7	138.7	92	30	80	Ø50	Ø70	M6	M8	17	21	204	Ø 55	G1/4"
GNP135	50	58.5	111	116.8	146.8	98	30	80	Ø50	Ø70	M6	M8	17	21	262	Ø 55	G1/4"
GNP198	57.5	64	122.5	133	163	109.5	30	80	Ø70	Ø102	M8	M10	22	26	268	Ø 55	G1/4"
GNP300	67.5	74.5	145.5	155	185	127.5	30	80	Ø70	Ø102	M8	M10	22	26	296	Ø 80	G1/4"
GNP513	75	77	160.7	171.5	201.5	137.5	30	80	Ø102	Ø125	M10	M12	27	31	390	Ø 80	G1/4"
GNP800	87	87	184	197	227	158	30	80	Ø102	Ø125	M10	M12	27	31	454	Ø 80	G1/4"
GNP1280	103	103	216	230	270	189	30	80/130	(Ø125)*	(Ø140)*	M12	M16	36	40	525	Ø 80	G1/4"
GNP1600	113	113	235.5	255	295	210	30	80/130	-	Ø140	-	M16	36	40	532	Ø 91	G1/4"
GNP2300	130	130	264	288	328	245	30	80/130	-	Ø140	-	M16	46	50	610	Ø 91	G1/4"
GNP2500	147	147	299	326	366	273	30	80/130	-	Ø165	-	M20	46	50	722	Ø 91	G1/4"

■ ( ) \* Scegliere una delle 2 opzioni / Choose one of two options



■ **Valvola a sfera a 2 pezzi /**  
2 pieces ball valve

M10

### Esempi di configurazioni / Configurations examples

Codice Code	Tipo Valvola Valve type	Tipo Attuatore* Actuator type	Misura Size
H501502120	H2015	D.E. - D.A.	1/4"
H501502124	H2015	S.E. - S.A.	1/4"
H501503120	H2015	D.E. - D.A.	3/8"
H501503124	H2015	S.E. - S.A.	3/8"
H501504122	H2015	D.E. - D.A.	1/2"
H501504126	H2015	S.E. - S.A.	1/2"
H501505122	H2015	D.E. - D.A.	3/4"
H501505132	H2015	S.E. - S.A.	3/4"
H501506122	H2015	D.E. - D.A.	1"
H501506136	H2015	S.E. - S.A.	1"
H501507128	H2015	D.E. - D.A.	1" 1/4
H501507140	H2015	S.E. - S.A.	1" 1/4
H501508128	H2015	D.E. - D.A.	1" 1/2
H501508144	H2015	S.E. - S.A.	1" 1/2
H501509128	H2015	D.E. - D.A.	2"
H501509148	H2015	S.E. - S.A.	2"

M10

### Esempi di configurazioni / Configurations examples



■ **Valvola a sfera a 3 pezzi /**  
3 pieces ball valve

Codice Code	Tipo Valvola Valve type	Tipo Attuatore* Actuator type	Misura Size
H502502120	900978	D.E. - D.A.	1/4"
H502502124	900978	S.E. - S.A.	1/4"
H502503120	900979	D.E. - D.A.	3/8"
H502503124	900979	S.E. - S.A.	3/8"
H502504122	900980	D.E. - D.A.	1/2"
H502504126	900980	S.E. - S.A.	1/2"
H502505122	900981	D.E. - D.A.	3/4"
H502505132	900981	S.E. - S.A.	3/4"
H502506122	900982	D.E. - D.A.	1"
H502506136	900982	S.E. - S.A.	1"
H502507128	900983	D.E. - D.A.	1" 1/4
H502507140	900983	S.E. - S.A.	1" 1/4
H502508128	900984	D.E. - D.A.	1" 1/2
H502508144	900984	S.E. - S.A.	1" 1/2
H502509128	900985	D.E. - D.A.	2"
H502509148	900985	S.E. - S.A.	2"

\* **D.E. - D.A.** = doppio effetto / double acting - **S.E. - S.A.** = singolo effetto /single acting



M10

### Esempi di configurazioni / Configurations examples



■ Valvola a farfalla /  
Butterfly valve

Codice Code	Tipo Valvola Valve type	Tipo Attuatore* Actuator type	Misura Size
H511109128	H2101	D.E. - D.A.	2"
H511109144	H2101	S.E. - S.A.	2"
H511110128	H2101	D.E. - D.A.	2" 1/2
H511110144	H2101	S.E. - S.A.	2" 1/2
H511111138	H2101	D.E. - D.A.	3"
H511111148	H2101	S.E. - S.A.	3"
H511112142	H2101	D.E. - D.A.	4"
H511112156	H2101	S.E. - S.A.	4"
H511113150	H2101	D.E. - D.A.	5"
H511114158	H2101	D.E. - D.A.	6"
H511116162	H2101	D.E. - D.A.	8"

M10

### Esempi di configurazioni / Configurations examples



■ Valvola a farfalla inox /  
SS butterfly valve

Codice Code	Tipo Valvola Valve type	Tipo Attuatore* Actuator type	Misura Size
H511409128	H2104	D.E. - D.A.	2"
H511409144	H2104	S.E. - S.A.	2"
H511410128	H2104	D.E. - D.A.	2" 1/2
H511410144	H2104	S.E. - S.A.	2" 1/2
H511411138	H2104	D.E. - D.A.	3"
H511411148	H2104	S.E. - S.A.	3"
H511412142	H2104	D.E. - D.A.	4"
H511412156	H2104	S.E. - S.A.	4"
H511413150	H2104	D.E. - D.A.	5"
H511414158	H2104	D.E. - D.A.	6"
H511416162	H2104	D.E. - D.A.	8"

Su richiesta /  
On request



Altre configurazioni disponibili  
a richiesta

Other models available on request



M10

## 5800 GNP

- **Corpo in alluminio estruso secondo la norma ASTM 6005, con anodizzazione dura come protezione contro la corrosione interna ed esterna. Speciale finitura interna del cilindro per ottenere un basso coefficiente di attrito, e verniciatura esterna a polvere di poliestere blu.**

Extruded aluminum ASTM6005 body with internal surface having honed cylinder for longer life and low friction coefficient, and both internal and external corrosion protection treated with hard anodized and the external blue powder polyester painted.

- **Il design compatto del pignone e della doppia cremagliera permette un montaggio simmetrico, un lungo ciclo di vita, nonché una rotazione inversa (in questo caso è necessaria solo una semplice inversione dei pistoni).**

Dual piston rack and pinion design for compact construction, symmetric mounting position, high-cycle life and fast operation, reverse rotation can be accomplished in the field by simply inverting the pistons.

### Caratteristiche costruttive / Construction features

- **Guide e cuscinetti multipli nella cremagliera e pistoni che riducono l'attrito, con un lungo ciclo di vita e design anti-espulsione dell'albero.**

Multiple bearings and guides on racks and pistons, low friction, high cycle life and prevent shaft blowout.

- **Design modulare della sede per le molle precaricate. Molle rivestite per garantire una maggiore resistenza alla corrosione ed un più lungo ciclo di vita.**

Modular preloaded spring cartridge design, with coated spring for simple versatile range, greater safety and corrosion resistance, longer cycle life.

- **Pistone e denti del pignone completamente lavorati per la massima efficienza e il minimo contraccolpo tra pignone e cremagliera.**

Fully machined teeth on piston and pinion for accurate low backlash rack and pinion engagement, maximum efficiency.

- **Elementi di fissaggio in acciaio inossidabile per una maggiore resistenza alla corrosione.**

Stainless steel fasteners for long term corrosion resistance.

- **Piena conformità alle più recenti specifiche: ISO5211, DIN 3337 e NAMUR per una grande adattabilità e facilità di montaggio di elettrovalvole, fincorsa e altri accessori.**

Full conformance to the latest specifications: ISO5211, DIN 3337 and NAMUR or product interchange ability and easy mounting of solenoids, limit switches and other accessories.

- **Approvazione ATEX secondo la direttiva 94/9/CE per atmosfere esplosive: Categoria II 2 GD T5/T100°C (Zone 1,2 / 21,22).**

ATEX certification according to 94/9/CE for explosive atmospheres: Class II 2 GD T5/T100°C (Zones 1,2 / 21,22).

### Dimensionamento doppio effetto / Double acting sizing

- **Il fattore di sicurezza consigliato per gli attuatori a doppio effetto in condizioni di funzionamento normale è compreso tra il 25% e il 35%.**

The suggested safety factor for Double Acting actuators under normal working conditions is 25%-35%.

#### Esempio / Example

- **La coppia richiesta per la valvola è = 100 Nm**  
The torque needed by valve=100Nm
- **La coppia maggiorata del fattore di sicurezza (100 + 30%) è di 130 Nm**  
The torque considered safety factor (100 + 30%) = 130Nm
- **Pressione dell'aria di alimentazione = 5 bar / Air Supply=5 bar**
- **Secondo la tabella delle coppie di azionamento, dobbiamo scegliere il modello che più si avvicina al valore di 130 Nm, nel nostro esempio il modello GNP 198.**

According to the above Torque Table, we have to choose the model that comes closest to the value of 130 Nm; in our example the model GNP198.

### Dimensionamento singolo effetto / Spring return sizing

- **Il fattore di sicurezza suggerito per attuatori ad azione singola a basso consumo energetico in condizioni di lavoro normali è compreso tra il 25% e il 35%.**

The suggested safety factor for spring return actuator under normal working conditions is 25-35%.

#### Esempio / Example

- **La coppia richiesta per la valvola = 100 Nm**  
The torque needed by valve = 100 Nm
- **La coppia considerando il fattore di sicurezza (100 + 30%) è di 130 Nm.**  
The torque consider safety factor (100 + 30%) = 130 Nm
- **Pressione dell'aria di alimentazione = 5 bar / Air Supply = 5 bar**

- **Secondo la tabella delle coppie fornitaci dagli attuatori a singolo effetto, troviamo che i valori di coppia del modello GNP 513 S4 (4+4 molle) sono:**

**Esercitata dall'aria a 0° = 291 Nm**  
**Esercitata dall'aria a 90° = 221 Nm**  
**Esercitata dalle molle a 90° = 206 Nm**  
**Esercitata dalle molle a 0° = 137 Nm**

According to the table of spring return actuators' output, we find output torque of GNP 513 S4 (4+4) are:

Air stroke 0°= 291 Nm  
Air stroke 90°= 221 Nm  
Spring stroke 90°=206 Nm  
Spring stroke 0°=137 Nm

- **Tutte le coppie ottenute sono superiori a quelle necessarie alla apertura e chiusura della valvola.**  
All the output torque are larger than we needed.

M10

### Coppie di azionamento attuatori doppio effetto (nm) / Double acting actuators torques (nm)

Modelli Model	Pressione alimentazione aria (bar) / Air supply pressure (bar)									
	2	2.5	3	4	4.5	5	5.5	6	7	8
GNP 14	4.8	6.0	7.2	9.5	10.7	11.9	13.1	14.3	16.7	19.1
GNP 24	8.0	10.0	12.0	16.0	18.0	20.0	21.9	23.9	27.9	31.9
GNP 44	14.6	18.2	21.9	29.2	32.8	36.5	40.1	43.8	51.1	58.4
GNP 60	20.1	25.1	30.1	40.1	45.1	50.2	55.2	60.2	70.2	80.3
GNP 94	31.4	39.2	47.0	62.7	70.5	78.4	86.2	94.1	109.7	125.4
GNP 135	45.1	56.4	67.7	90.3	101.6	112.9	124.1	135.4	158.0	180.6
GNP 198	66.1	82.7	99.2	132.2	148.8	165.3	181.8	198.4	231.4	264.5
GNP 300	100.3	125.4	150.5	200.6	225.7	250.8	275.9	301.0	351.1	401.3
GNP 513	171.0	213.8	256.5	342.0	384.8	427.5	470.3	513.0	598.5	684.0
GNP 800	266.0	332.5	399.0	532.0	598.5	665.0	731.5	798.0	931.0	1064.0
GNP 1280	425.6	532.0	638.4	851.2	957.6	1064.0	1170.4	1276.8	1489.6	1702.4
GNP 1600	532.0	665.0	798.0	1064.0	1197.0	1330.0	1463.0	1596.0	1862.0	2128.0
GNP 2300	769.5	961.9	1154.3	1539.0	1731.4	1923.8	2116.1	2308.5	2693.3	3078.0
GNP 2500	1169.6	1462.1	1754.5	2339.3	2631.7	2924.1	3216.5	3508.9	4093.7	4678.6
GNP 3000	1526.0	1908.0	2671.0	3052.0	3434.0	3815.0	4197.0	4578.0	5341.0	6104.0
GNP 3500	2285.0	2856.0	3999.0	4570.0	5141.0	5712.0	6283.0	6854.0	7997.0	9139.0

### Molle / Springs

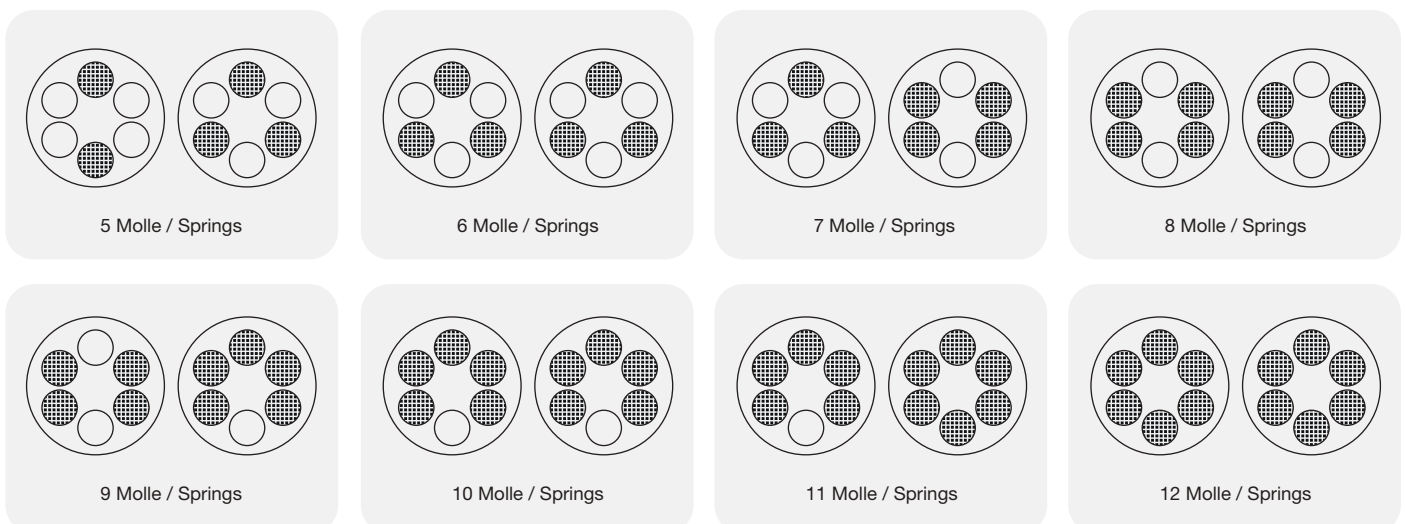

M10

**Coppie di azionamento attuatori singolo effetto (nm) /**  
**Single acting actuators torques (nm)**

Tipo Type	Numero di molle Spring Qty	Pressione alimentazione aria (bar) / Air supply pressure (bar)														Ottenuto dalle molle Spring output		
		2,5		3		4		5		6		7		8		90°	0°	
		0°	90°	0°	90°	0°	90°	0°	90°	0°	90°	0°	90°	0°	90°			
GNP 24S	3 + 2	5.7	3.8	7.6	5.7												6.2	4.3
	3 + 3	4.9	2.5	6.9	4.5	10.9	8.5										7.4	5.0
	4 + 3	4.0	1.3	6.0	3.3	9.8	7.3	14.0	10.4								8.6	5.9
	4 + 4			5.2	2.0	9.2	6.0	13.2	9.1	17.2	14.1						9.9	6.7
	5 + 4			4.3	0.8	8.3	4.8	12.3	7.9	16.3	12.8	20.3	16.8				11.1	7.6
	5 + 5					7.4	3.6	11.5	6.7	15.5	11.6	19.5	15.6				12.4	8.5
	6 + 5					6.6	2.3	10.6	5.4	14.6	10.4	18.6	14.3	22.6	18.3		13.6	9.3
	6 + 6							9.7	4.2	13.8	9.1	17.8	12.2	21.8	17.1		14.8	10.2
GNP 44S	3 + 2	11.4	7.7	15.0	11.4	22.3	14.9										10.4	6.8
	3 + 3	10.1	5.7	13.6	9.3	20.9	16.6	28.3	23.9								12.5	8.2
	4 + 3	8.6	3.6	12.5	7.2	19.5	14.5	26.8	21.9								14.6	9.6
	4 + 4			10.9	5.1	18.2	12.4	25.5	19.8	32.8	27.0	40.1	34.3				16.7	10.9
	5 + 4					16.8	10.4	24.1	17.7	31.4	24.9	38.7	32.3				18.8	12.3
	5 + 5					1.4	8.2	22.8	15.6	30.0	22.8	37.3	30.1	44.7	37.4		20.9	13.7
	6 + 5							21.5	13.5	28.7	20.7	36.0	28.0	43.3	35.3		22.9	15.0
	6 + 6							20.0	11.4	27.3	18.6	34.6	25.9	41.9	33.3		25.0	16.4
GNP 60S	3 + 2	14.5	10.6	19.4	15.5	29.5	25.7										14.5	10.5
	3 + 3	12.4	7.6	17.3	12.6	27.4	22.7	37.5	32.8								17.4	12.7
	4 + 3	10.4	4.8	15.2	9.7	25.3	19.6	35.4	29.9								20.3	14.8
	4 + 4			13.1	6.8	23.1	16.9	33.3	27.0	43.2	37.0	53.3	47.0				23.2	16.9
	5 + 4					21.0	14.1	31.2	24.1	41.1	34.1	51.2	44.2				26.1	19.0
	5 + 5					19.0	11.1	28.8	21.2	39.0	31.2	49.1	41.2	59.1	51.2		29.0	21.1
	6 + 5							27.0	8.3	37.0	28.3	47.0	38.4	57.0	48.4		31.9	23.2
	6 + 6							24.9	15.4	34.9	25.4	44.9	35.4	54.9	45.4		34.7	25.3
GNP 94S	3 + 2	23.3	16.1	31.1	24.0	46.8	39.7										23.0	15.8
	3 + 3	20.1	11.5	28.0	19.3	43.7	35.1	59.4	50.7								27.6	19.0
	4 + 3	17.0	6.9	24.8	14.8	40.5	30.5	56.2	46.2								32.2	22.1
	4 + 4			21.7	10.1	37.4	25.8	53.1	41.5	68.8	57.2	84.5	72.9				36.8	25.3
	5 + 4					34.2	21.3	49.9	37.0	65.6	52.6	81.2	68.3				41.4	28.5
	5 + 5					31.0	16.6	46.7	32.3	62.4	48.0	78.1	63.7	93.8	79.3		46.0	31.6
	6 + 5							43.6	27.7	59.3	43.4	75.0	59.1	90.6	74.8		50.6	34.8
	6 + 6							40.4	23.2	56.1	38.9	71.7	54.5	87.4	70.2		55.2	38.0
GNP 135S	3 + 2	33.1	22.0	44.2	33.2	66.8	55.9										34.4	23.3
	3 + 3	28.4	15.2	39.6	26.4	62.2	49.0	84.4	71.6								41.2	28.0
	4 + 3	23.8	8.2	34.9	19.4	57.5	42.1	80.2	64.7								48.1	32.7
	4 + 4			31.3	12.6	52.9	35.2	75.5	57.9	98.1	80.5	120.7	103.0				55.0	37.3
	5 + 4					48.2	28.4	70.9	51.0	93.5	73.6	116.0	96.1				61.9	42.0
	5 + 5					43.6	21.5	66.2	44.1	88.8	66.7	111.3	89.2	134.0	111.8		68.7	46.7
	6 + 5							61.5	37.2	84.1	59.9	106.6	82.4	129.2	105.0		75.6	51.4
	6 + 6							56.8	30.4	79.4	53.0	101.9	75.5	124.5	98.1		82.5	56.0
GNP 198S	3 + 2	51.0	33.4	67.5	49.9	100.6	83.0										49.2	31.6
	3 + 3	44.7	23.5	61.1	40.0	94.2	73.2	127.3	106.2								59.1	38.0
	4 + 3	38.4	13.7	54.9	30.3	87.9	63.4	121.0	96.4								68.9	44.3
	4 + 4			48.5	20.4	81.6	53.5	114.7	86.5	147.7	119.6	180.8	152.7				78.7	50.6
	5 + 4					75.3	43.7	108.4	76.8	141.5	109.8	174.5	142.9				88.6	56.9
	5 + 5					68.9	33.4	102.0	66.5	136.1	99.6	168.2	132.6	201.2	165.7		98.4	63.3
	6 + 5							95.7	57.0	128.7	90.1	161.8	123.1	194.8	156.2		108.3	69.6
	6 + 6							89.4	47.5	122.5	80.6	155.5	113.6	188.6	146.7		118.1	75.9
GNP 300S	3 + 2	73	47	98	72	148	122										79	52
	3 + 3	63	31	88	56	138	107	188	157								94	63
	4 + 3	52	15	77	40	127	90	178	141								110	73
	4 + 4			67	25	117	75	167	125	217	176	268	226				125	84
	5 + 4					107	59	157	109	207	159	257	210				141	94
	5 + 5					96	44	146	94	196	144	247	194	297	245		157	105
	6 + 5							136	78	186	128	236	178	286	228		173	115
	6 + 6							125	63	176	113	226	163	276	213		188	125
GNP 513S	3 + 2	128	85	171	127	256	213										129	86
	3 + 3	111	59	154	102	239	187	325	273								155	103
	4 + 3	94	33	137	76	222	162	308	247								181	120
	4 + 4			120	50	205	136	291	221	376	307	462	392				206	137
	5 + 4					187	110	273	196	358	281	444	367				232	155
	5 + 5					170	84	256	169	341	255	427	340	512	426		258	172
	6 + 5							238	143	324	229	409	314	495	400		284	189
	6 + 6							221	118	307	203	392	289	478	374		310	206

M10

**Coppie di azionamento attuatori doppio effetto (nm) /**  
 Double acting actuators torques (nm)

Tipo Type	Numero di molle Spring Qty	Pressione alimentazione aria (bar) / Air supply pressure (bar)														Ottenuto dalle molle Spring output		
		2,5		3		4		5		6		7		8		90°	0°	
		0°	90°	0°	90°	0°	90°	0°	90°	0°	90°	0°	90°	0°	90°			
GNP 800S	3 + 2	193	124	259	191	392	324										208	140
	3 + 3	165	83	232	149	365	282	498	415								250	168
	4 + 3	137	41	203	107	336	240	469	373								292	196
	4 + 4			176	66	309	199	442	237	575	465	708	598				333	223
	5 + 4					280	157	413	290	546	423	679	556				375	251
	5 + 5					253	115	386	248	519	381	652	514	785	647		417	279
	6 + 5							358	207	491	340	624	473	757	606	458	307	
6 + 6							330	165	463	298	596	431	729	564	500	335		
GNP 1280S	3 + 2	332	222	438	329	651	542										309	200
	3 + 3	292	161	398	267	611	480	824	693								371	240
	4 + 3	252	99	358	205	571	418	784	631								433	280
	4 + 4			318	143	531	356	744	569	957	782	1169	995				495	320
	5 + 4					491	295	704	507	917	720	1130	933				557	360
	5 + 5					451	233	664	446	877	658	1090	871	1302	1084	618	400	
	6 + 5							624	384	837	597	1050	809	1263	1022	680	440	
6 + 6							584	322	797	535	1010	748	1223	960	742	480		
GNP 1600S	3 + 2	390	285	52	418	789	684										380	275
	3 + 3	335	209	468	342	734	608	1000	874								456	330
	4 + 3	280	133	413	266	679	532	945	798								532	385
	4 + 4			358	190	624	456	890	722	1156	988	1422	1254				608	440
	5 + 4					569	380	835	646	1101	912	1367	1178				684	495
	5 + 5					514	304	780	570	1046	836	1312	1102	1578	1368	760	550	
	6 + 5							725	494	991	760	1257	1026	1523	1292	836	605	
6 + 6							670	418	936	684	1202	950	1468	1216	912	660		
GNP 2300S	3 + 2	552	409	744	600	1129	985										554	410
	3 + 3	470	297	662	489	1047	874	1432	1259								665	492
	4 + 3	388	187	580	379	964	764	1349	1149								775	575
	4 + 4			498	268	883	653	1267	1037	1652	1422	2037	1807				886	656
	5 + 4					800	542	1185	926	1569	1311	1954	1696				998	739
	5 + 5					718	431	1103	816	1488	1201	1872	1586	2257	1970	1108	821	
	6 + 5							1021	705	1408	1090	1791	1474	2176	1859	1219	903	
6 + 6							939	594	1323	979	1708	1363	2093	1748	1330	985		
GNP 2500S	3 + 2	903	675	1195	968	1779	1552										787	560
	3 + 3	790	519	1083	811	1667	1396	2252	1981								943	672
	4 + 3	679	361	972	654	1556	1238	2141	1823								1101	783
	4 + 4			860	497	1444	1081	2029	1666	2614	2252	3199	2836				1258	895
	5 + 4					1332	923	1917	1509	2502	2094	3087	2678				1416	1007
	5 + 5					1220	767	1806	1352	2390	1937	2974	2521	3560	3107	1572	1119	
	6 + 5							1693	1194	2278	1779	2862	2364	3448	2949	1730	1231	
6 + 6							1582	1037	2167	1623	2751	2207	3336	2792	1887	1342		
GNP 3000S	3 + 2	1097	729														1061	730
	3 + 3	935	494	1316	875												1273	876
	4 + 3	772	258	1153	639	1916	1402										1485	1022
	4 + 4			991	403	1754	1166	2517	1929								1697	1168
	5 + 4					1592	930	2355	1693	3118	2456						1909	1314
	5 + 5					1430	695	2193	1458	2956	2221	3719	2984	4482	3747	2122	1460	
	6 + 5							2030	1222	2793	1985	3556	2748	4319	3511	2334	1606	
6 + 6							1868	986	2631	1749	3394	2512	4157	3275	2546	1752		
GNP 3500S	3 + 2	1553	964														1702	1173
	3 + 3	1292	586	1863	1157												2043	1408
	4 + 3	1031	208	1602	779	2745	1922										2383	1640
	4 + 4			1341	401	2484	1544	3626	2686								2724	1877
	5 + 4					2224	1165	3366	2307	4508	3449						3064	2112
	5 + 5					1963	787	3105	1929	4247	3071	5390	4214	6532	5356	3405	2346	
	6 + 5							2844	1551	3986	2693	5129	3836	6271	4978	3745	2581	
6 + 6							2584	1172	3726	2314	4869	3457	6011	4599	4086	2816		

M10

**Modello / Model**  
**H4519**

**Tensione / Voltage tolerance**  
- 15% +10%

**Operating pressure / Operating pressure**  
min. 1,5 bar – max. 8 bar

**Pressione / Pressure**  
max 12 bar

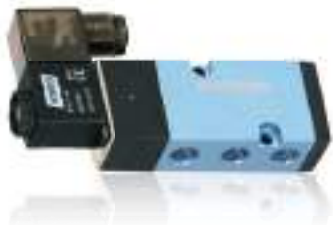

### Caratteristiche tecniche / Construction features

- **Elettrovalvola a 5 vie, 2 posizioni monostabile** / 5 ways, 2 positions single stable solenoid valve
- **Secondo** / According to NAMUR VDI/VDE 3845
- **Attacchi alimentazione e scarico aria** / Inlet and outlet air connections: 1/4" F
- **Grado di protezione** / Protection grade IP 65
- **Dispositivo di azionamento manuale incluso** / Manual override included
- **Accessori compresi** /Accessories included:
  - a) **Connettore con indicazione luminosa** / Connector with light signal Pg-9 DIN43650 "B"
  - b) **O-ring e viti di fissaggio** / O-rings and screws for mounting

### Modelli disponibili / Available models

Codice Code	Tipo corrente Current type	Tensione Voltage
H451902110V	AC	110V - 50Hz
H451902220V	AC	220V - 50Hz
H451902A24V	AC	24V - 50Hz
H451902A48V	AC	48V - 50Hz
H451902C12V	CC / DC	12V
H451902C24V	CC / DC	24V

M10

**Modello / Model**  
**H5987**

**Grado protezione** / Protection grade  
IP 67 (cassa esterna / external case)

**Supporto** / Bracket  
NAMUR mm 30x80 H=30



### Caratteristiche tecniche / Construction features

- **Cassa microinterruttore fine corsa per attuatori pneumatici** / Limit switch box for pneumatic actuators
- **Secondo** / According to NAMUR VDI/VDE 3845
- **Versioni disponibili** / Available versions:
  - Elettromeccanico / Electromechanical
  - Induttivo / Inductive

### Modelli disponibili / Available models

Codice Code	Tipo microinterruttore Limit switch type
H598702	<b>Elettromeccanico</b> / Electromechanical
H598704	<b>Induttivo 2 fili</b> / Inductive 2 wires
H598706	<b>Induttivo 3 fili</b> / Inductive 3 wires
H598708	<b>Induttivo 2 fili ATEX</b> / Inductive 2 wires ATEX
H598710	<b>Elettromeccanico cassa ATEX</b> / Electromechanical ATEX box
H598712	<b>Induttivo 2 fili con cassa ATEX</b> / Inductive 2 wires with ATEX box

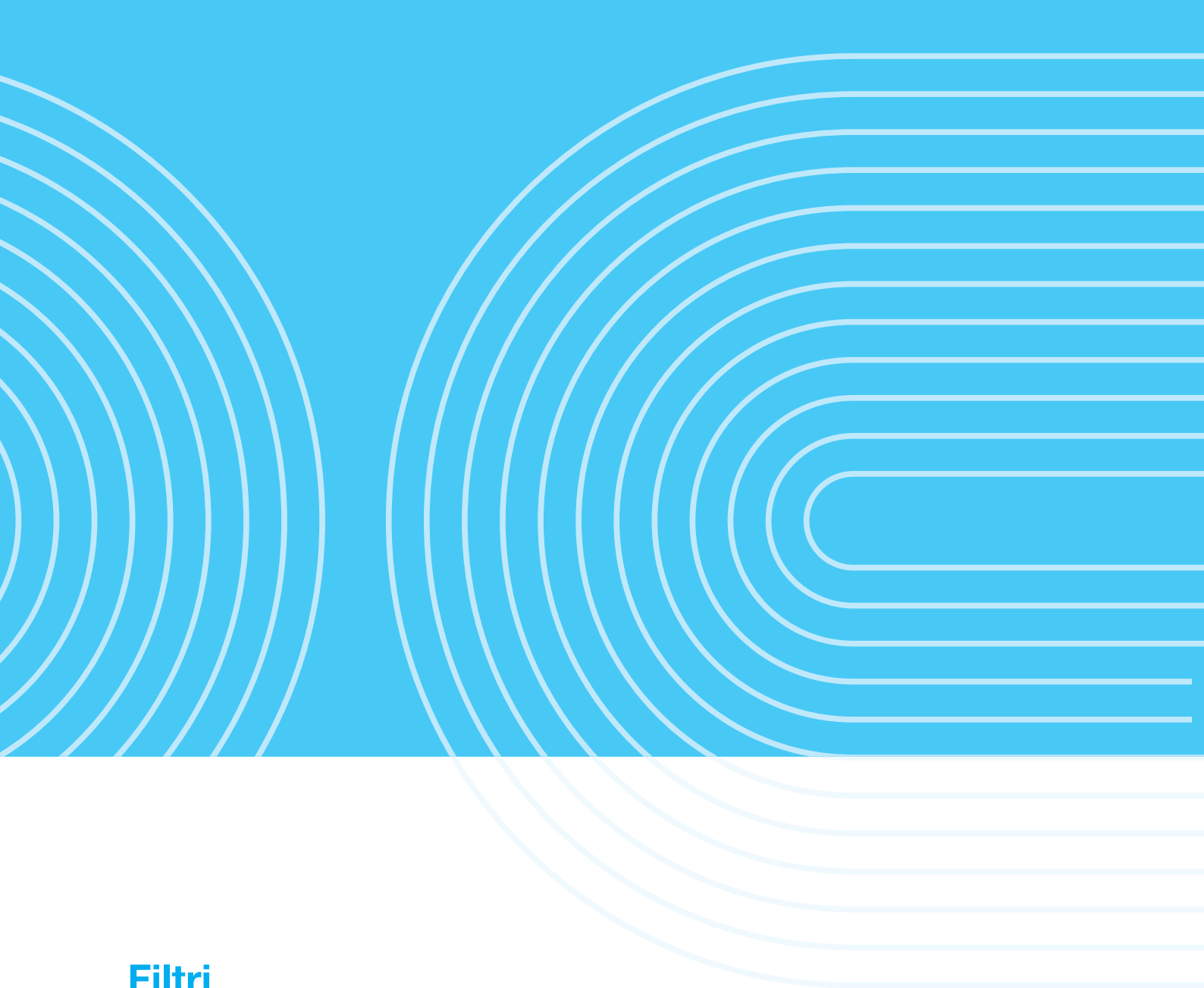

## Filtri idraulici Hydraulic filters

- **I filtri hanno la funzione di eliminare le impurità presenti nei liquidi che circolano all'interno di un impianto idraulico. Possono essere installati sia nel punto di aspirazione che all'interno dell'impianto per proteggerlo da eventuali danneggiamenti a pompe, sensori e strumenti di misura a causa delle particelle solide in sospensione. Sono disponibili in acciaio inox, ottone e acciaio zincato con diametro da 1/4" fino a 4" e oltre.**  
Filters eliminate the impurities in the liquids that circulate inside a hydraulic system. They can be installed either at the inlet point or inside the system to prevent the solid particles in suspension

from damaging pumps, sensors and measuring instruments. They are available in stainless steel, brass and galvanized steel with diameters from 1/4" to 4" and larger.

- **La pressione massima è di 40 bar e la temperatura massima di 240°C. Le applicazioni sono sia domestiche che industriali.** / They can be used in both domestic and industrial environments where the maximum pressure reaches 40 bar and the maximum temperature 240°C.

M1

## IDRJA-SMALL

Filtri di aspirazione / Suction screens

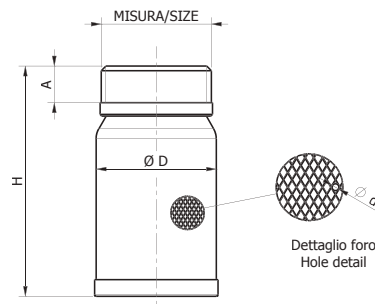
**Modello / Model**  
**IDRJA-SMALL**
**Materiale / Material**  
 Aisi 304 / Aisi 316

**DN**  
 8 – 100

**Caratteristiche tecniche /**  
 Construction features

- **Connessione filettata maschio secondo /**  
Threaded end gas male according to  
UNI ISO 228/1
- **Grado di filtrazione / Filtration**  
U.S. mesh: 18 (da/from 3/8" a/to 2")  
U.S. mesh: 10 (da/from 2" 1/2 a/to 4")
- **Trattamento superficiale solo per versione**  
**Aisi 316 sgrassaggio,decapaggio ed**  
**elettrolucidatura / Surface treatment only Aisi**  
316 version degreasing, pickling  
and electropolishing

**Componenti e materiali /**  
 Components and materials

<b>Rete /</b> Net-filter	Acciaio inox Aisi 304 o 316 / SS Aisi 304 or 316
<b>Fondello /</b> Net cap	Acciaio inox Aisi 304 o 316 / SS Aisi 304 or 316
<b>Raccordo maschio /</b> Male coupling	Acciaio inox Aisi 304 o 316 / SS Aisi 304 or 316

**Dimensioni e pesi /**  
 Dimensions and weights

Codice Code	Materiale Material	Misura Size	DN	Peso in gr. Weight in gr.	Dimensioni in mm Dimensions in mm			
					H	A	Ø D	Ø d
900920	Aisi 304	3/8"	8	12	55	8	19	1
900921		1/2"	15	15	55	10	22	1
900922		3/4"	20	25	62	10	28	1
900923		1"	25	34	71	11	36	1
900924		1" 1/4	32	52	80	15	43	1
900925		1" 1/2	40	62	90	15	49	1
900926		2"	50	86	101	15	60	1
900927		2" 1/2	65	135	111	18	79	1,8
900928		3"	80	168	125	18	92	1,8
900929	4"	100	253	144	20	115	1,8	
900931	Aisi 316	3/8"	8	12	55	8	19	1
900910		1/2"	15	15	55	10	22	1
900911		3/4"	20	25	62	10	28	1
900912		1"	25	34	71	11	36	1
900913		1" 1/4	32	52	80	15	43	1
900914		1" 1/2	40	62	90	15	49	1
900915		2"	50	86	101	15	60	1
900916		2" 1/2	65	135	111	18	79	1,8
900917		3"	80	168	125	18	92	1,8
900918		4"	100	253	144	20	115	1,8



M2

90093

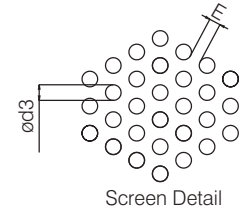
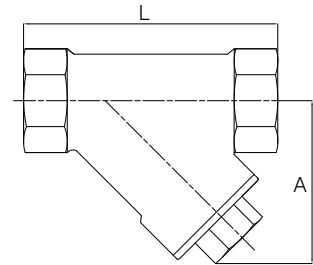
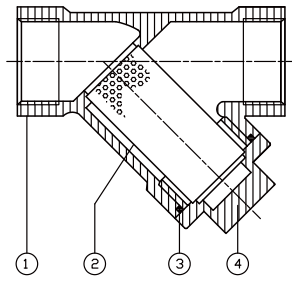
Filtri a y /  
"Y" type strainers

Screen Detail

Modello / Model

90093

Materiale / Material

Aisi 316

DN

8 – 50

PN

40

### Caratteristiche tecniche / Construction features

- **Connessioni filettate gas femmina secondo** / Threaded ends gas female according to EN 10226-1
- **Pressione nominale di esercizio** / Nominal working pressure 40 bar
- **Temperatura di esercizio** / Working temperature  $-30^{\circ}\text{C} - +240^{\circ}\text{C}$

### Diagramma pressione temperatura / Pressure temperature diagram

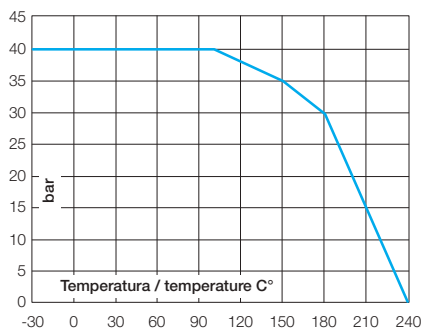

### Componenti e materiali / Components and materials

1	<b>Corpo</b> / Body	Acciaio inox / SS 1.4408
2*	<b>Filtro</b> / Strainer	Acciaio inox / SS Aisi 316
3*	<b>Guarnizione</b> / Gasket	PTFE
4	<b>Tappo</b> / Plug	Acciaio inox / SS 1.4408

\* **Ricambi disponibili** / Spare parts

### Dimensioni e pesi / Dimensions and weights

Codice Code	Misura Size	DN	PN	Peso in kg. Weight in kg.	KV m <sup>3</sup> /h	Dimensioni in mm Dimensions in mm			
						A	L	Ød3	E
900933	1/4"	8	40	0,29	1,44	30	65	1,0	1,0
900934	3/8"	10	40	0,21	2,88	30	65	1,0	1,0
900935	1/2"	15	40	0,22	3,30	40	65	1,0	1,0
900936	3/4"	20	40	0,35	6,60	45	80	1,0	1,0
900937	1"	25	40	0,66	9,70	55	90	1,0	1,0
900938	1" 1/4	32	40	0,77	14,90	65	105	1,0	1,0
900939	1" 1/2	40	40	1,15	26,60	70	120	1,0	1,0
900940	2"	50	40	1,76	35,40	85	140	1,0	1,0

Su richiesta /  
On request

Filettatura NPT / NPT thread

M1

# LINIA

Filtri in linea /  
In-line filters

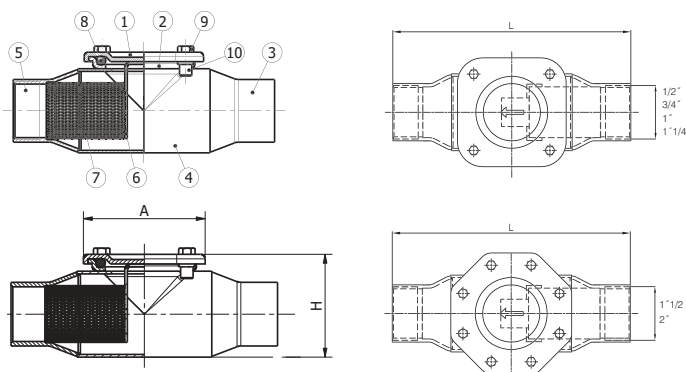

Modello / Model

LINIA

Materiale / Material

Aisi 304

DN

15 – 50

PN

16

## Caratteristiche tecniche / Construction features

- **Massimo rendimento: perdite di carico altamente inferiori ai tradizionali filtri a Y** / Maximum efficiency: much lower friction losses than traditional "Y" type strainers
- **Lavorazione acciaio inox stampato** / Manufacturing process pressed stainless steel
- **Connessioni filettate gas femmina secondo** / Threaded ends gas female UNI ISO 228/1
- **Saldature a TIG senza apporto di materiale** / Welded joints made with TIG method without any additional material
- **Trattamento superficiale decapaggio e elettrolucidatura** / Surface treatment pickling and electropolishing
- **Test idraulico su saldature aria compressa su ogni filtro** / Hydraulic test on welded joints compressed air on each filter a/at 2 bar
- **Pressione nominale di esercizio** / Nominal working pressure 16 bar
- **Temperatura di esercizio** / Working temperature -10°C – +150°C (FPM)
- **Grado di filtrazione** / Filtration 500 µ (da/from 1/2" a/to 1") 800 µ (da/from 1" 1/4 a/to 2")

## Componenti e materiali / Components and materials

1	Coperchio / Cover	1.4301 EN 10088 (Aisi 304)
2*	Base coperchio / Cover base	1.4301 EN 10088 (Aisi 304)
3	Manicotto lato mandata / Outlet end	1.4301 EN 10088 (Aisi 304)
4	Corpo filtro / Body	1.4301 EN 10088 (Aisi 304)
5	Manicotto lato aspirazione / Inlet end	1.4301 EN 10088 (Aisi 304)
6*	Reggifiltro / Filter net holder	1.4301 EN 10088 (Aisi 304)
7*	Filtro / Filter net	1.4301 EN 10088 (Aisi 304)
8*	Anello OR / O-ring	FPM
9*	Vite TE M5 / Screw TE M5	Acciaio inox / SS Aisi 304
10	Rivetto / Rivet	Acciaio inox / SS Aisi 304

\* Ricambi disponibili / Spare parts

## Perdite di carico / Friction losses diagrams

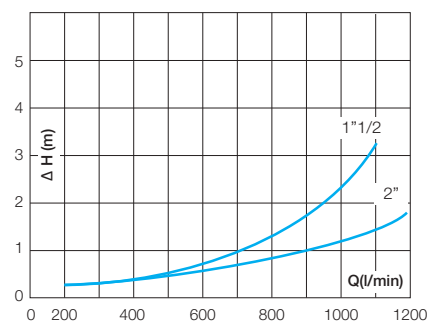
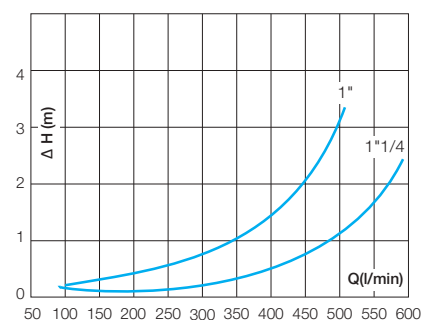
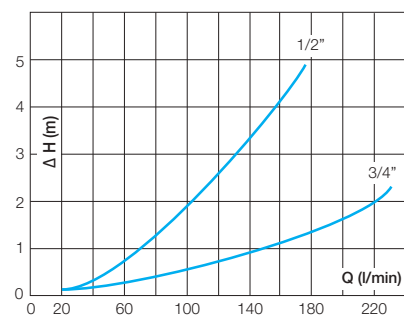

## Dimensioni e pesi / Dimensions and weights

Codice Code	Misura Size	DN	PN	Peso in gr. Weight in gr.	Dimensioni in mm Dimensions in mm		
					A	H	L
900805	1/2"	15	16	200	48,6	43,7	106
900806	3/4"	20	16	285	54,6	52,9	128
900807	1"	25	16	420	68,5	61,3	148
900808	1" 1/4	32	16	725	85,0	78,0	180
900809	1" 1/2	40	16	1.020	106,0	90,6	219
900810	2"	50	16	1.400	121,5	103,4	228

M1

# LINIA / 2.0

Filtri in linea /  
In-line filters

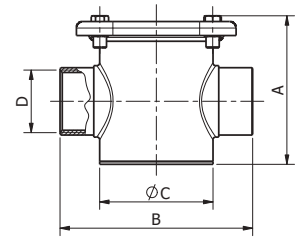
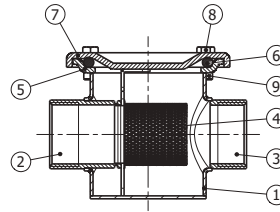

Modello / Model  
**LINIA 2.0**

Materiale / Material  
Aisi 316

DN  
15 – 40

PN  
16

## Caratteristiche tecniche / Construction features

- **Lavorazione: acciaio inox stampato /**  
Manufacturing process: pressed stainless steel
- **Trattamento superficiale sgrassaggio, decapaggio ed elettrolucidatura /**  
Surface treatment degreasing, pickling and electropolishing
- **Connessioni filettate gas femmina secondo /**  
Threaded ends gas female according to UNI ISO 228/1
- **Saldature a TIG senza apporto di materiale /**  
Welded joints: made with TIG method without any additional material
- **Pressione nominale di esercizio /**  
Nominal working pressure 16 bar
- **Temperatura di esercizio /**  
Working temperature -20°C – +180°C
- **Grado di filtrazione /** Filtration  
800 μ (da/from 1/2" a/to 1")  
1000 μ (1" 1/4 e/and 1"1/2)

## Componenti e materiali / Components and materials

1	<b>Corpo /</b> Body	Acciaio inox / SS Aisi 316
2	<b>Manicotto lato mandata /</b> Outlet end	Acciaio inox / SS Aisi 316
3	<b>Manicotto lato aspirazione /</b> Inlet end	Acciaio inox / SS Aisi 316
4*	<b>Filtro /</b> Filter	Acciaio inox / SS Aisi 316
5	<b>Base coperchio /</b> Cover base	Acciaio inox / SS Aisi 316
6*	<b>Anello OR /</b> O-ring	FPM
7*	<b>Coperchio /</b> Cover	Acciaio inox / SS Aisi 316
8*	<b>Vite TE M5 /</b> Screw TE M5	Acciaio inox / SS Aisi 304
9	<b>Rivetto /</b> Rivet	Acciaio inox / SS Aisi 304

\* **Ricambi disponibili /** Spare parts

## Dimensioni e pesi / Dimensions and weights

Codice Code	Misura Size	DN	PN	Peso in gr. Weight in gr.	Dimensioni in mm Dimensions in mm			
					A	B	C	D
900815	1/2"	15	16	257	65	78	42,4	1/2" F
900816	3/4"	20	16	368	72	84	48,3	3/4" F
900817	1"	25	16	570	79	105	48,3	1" F
900818	1" 1/4	32	16	880	90	116	76,1	1" 1/4 F
900819	1" 1/2	40	16	1.130	102	137	88,9	1" 1/2 F

M2

90094

Filtri a y flangiati /  
Flanged "y" type strainers

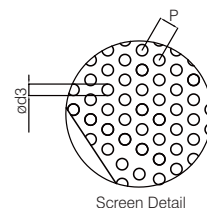
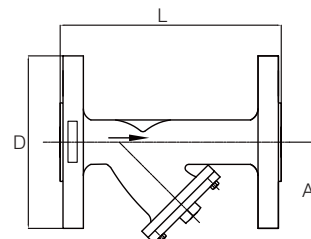
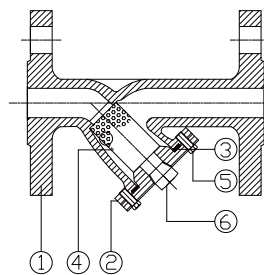

Modello / Model  
**90094**

Materiale / Material  
Aisi 316

DN  
15 – 200

PN  
16

### Caratteristiche tecniche / Construction features

- **Conessioni flangiate secondo** / Flanged ends according to EN 1092 PN16
- **Scartamento** / Face to face EN 558 S.1
- **Pressione nominale di esercizio** / Nominal working pressure 16 bar
- **Temperatura di esercizio** / Working temperature -30°C – +240°C

### Diagramma pressione temperatura / Pressure temperature diagram

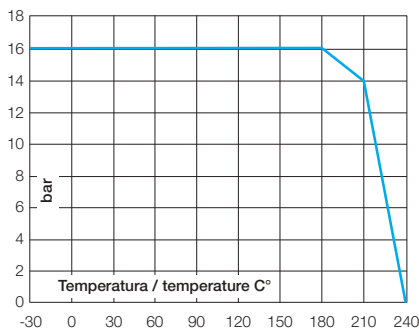

### Componenti e materiali / Components and materials

1	Corpo / Body	Acciaio inox / SS Aisi 316
2	Coperchio / Cover	Acciaio inox / SS Aisi 316
3*	Guarnizione / Gasket	PTFE
4*	Filtro / Strainer	Acciaio inox / SS Aisi 316
5	Vite / Bolt	Acciaio inox / SS Aisi 304
6	Tappo / Plug	Acciaio inox / SS Aisi 316 (a partire dalla misura /starting from size 1"1/4)

\* **Ricambi disponibili** / Spare parts

### Dimensioni e pesi / Dimensions and weights

Codice Code	Misura Size	DN	PN	Peso in kg. Weight in kg.	KV m³/h	Dimensioni in mm Dimensions in mm				
						A	D	L	P	Ø d3
900941	1/2"	15	16	1,95	3,3	75	95	130	2	1,0
900942	3/4"	20	16	2,75	6,6	90	105	150	2	1,0
900943	1"	25	16	3,7	9,7	100	115	160	2	1,0
900944	1" 1/4	32	16	5,9	14,9	115	140	180	2	1,0
900945	1" 1/2	40	16	6,4	26,6	130	150	200	2	1,0
900946	2"	50	16	8,9	35,4	150	165	230	2	1,0
900947	2" 1/2	65	16	13	67,2	190	185	290	3,5	2,0
900948	3"	80	16	18,2	96,1	200	200	310	3,5	2,0
900949	4"	100	16	24,3	149	230	220	350	3,5	2,0
H246113	5"	125	16	30	198,5	280	250	400	3,5	2,0
H246114	6"	150	16	42	294,6	300	285	480	3,5	2,0
H246116	8"	200	16	75	462,5	400	340	605	3,5	2,0

M3

## H1000

**Filtri a y filettati in ottone / Brass "y" type strainers**

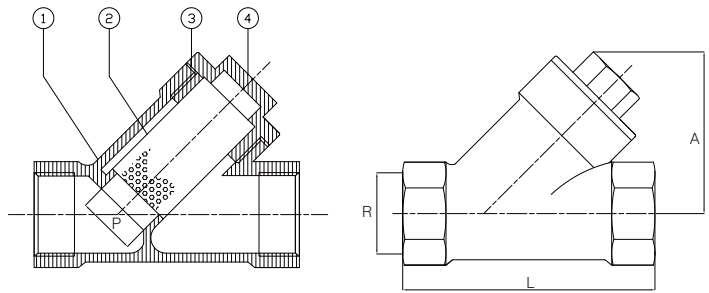

Modello / Model

H1000

Materiale / Material

Ottone / Brass

DN

15 – 100

PN

16

### Caratteristiche tecniche / Construction features

- **Connessioni filettate gas femmina secondo** / Threaded ends gas female according to UNI ISO 228/1
- **Pressione nominale di esercizio** / Nominal working pressure 16 bar
- **Temperatura di esercizio** / Working temperature -20°C – +100°C
- **Grado di filtrazione** / Filtration 500 µ fino a / up to 2" 1200 µ da / from 2"1/2

### Componenti e materiali / Components and materials

1	<b>Corpo</b> / Body	Ottone / Brass
2	<b>Filtro</b> / Strainer	Acciaio inox / SS Aisi 304
3	<b>Guarnizione</b> / Gasket	NBR
4	<b>Tappo</b> / Plug	Ottone / Brass

### Diagramma pressione temperatura / Pressure temperature diagram

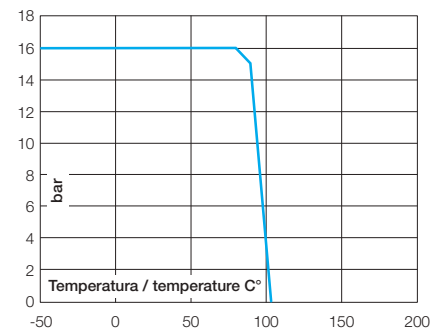

### Dimensioni e pesi / Dimensions and weights

Codice Code	Misura Size	DN	PN	Peso in gr. Weight in gr.	KV m <sup>3</sup> /h	Dimensioni in mm Dimensions in mm	
						L	A
H100002	1/2"	15	16	115	4,3	56,5	38
H100003	3/4"	20	16	195	7,5	66	44
H100004	1"	25	16	265	10	74	50
H100005	1" 1/4	32	16	540	15	96	66
H100006	1" 1/2	40	16	610	21	104	71
H100007	2"	50	16	1.150	33,5	125	89
H100008	2" 1/2	65	16	2.100	78	154	110
H100009	3"	80	16	2.900	92	173	120
H100010	4"	100	16	5.500	145	210	152

M3

# AMITA

**Filtri di aspirazione con  
manicotto in PA / Suction  
screens with PA coupling**

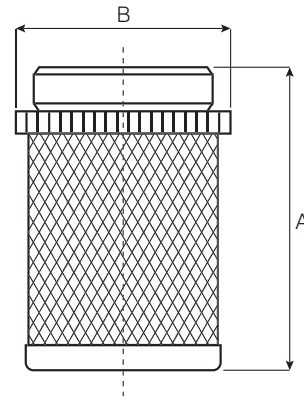

**Modello / Model**  
**AMITA**

**Materiale / Material**  
Aisi 304

**DN**  
8 – 100

## Caratteristiche tecniche / Construction features

- **Connessione filettata gas maschio secondo** / Threaded end gas male UNI ISO 228/1
- **Grado di filtrazione** / Filtration  
1000  $\mu$  fino a/ up to 2"  
1200  $\mu$  da/from 2"1/2
- **Temperatura d'esercizio** / Working temperature  
max 90°

## Componenti e materiali / Components and materials

**Rete /** Acciaio inox /  
Net-filter SS Aisi 304

**Raccordo maschio /** PA (nylon)  
Male coupling

## Dimensioni e pesi / Dimensions and weights

Codice Code	Misura Size	DN	Peso in gr. Weight in gr.	Dimensioni in mm Dimensions in mm		Foro Hole $\varnothing$ D mm
				A	B	
900900	3/8"	8	6	49	23	1,0
900901	1/2"	15	7	51	28	1,0
900902	3/4"	20	11	57	34	1,0
900903	1"	25	15	58	40	1,0
900904	1" 1/4	32	19	69	48	1,0
900905	1" 1/2	40	29	81	58	1,0
900906	2"	50	41	96	68	1,0
900907	2" 1/2	65	64	96	83	1,2
900908	3"	80	73	116	100	1,2
900909	4"	100	153	132	127	1,2

M3

Modello / Model  
**H2451**

Materiale / Material  
Acciaio zincato / Galvanized steel

DN  
50 – 250

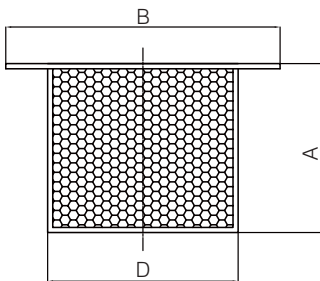

### Caratteristiche tecniche / Construction features

- **Filtri di aspirazione** / Suction screens
- **Pressione nominale di esercizio** / Nominal working pressure  
16 bar
- **Temperatura di esercizio** / Working temperature  
-10°C – + 100°C

### Dimensioni e pesi / Dimensions and weights

Codice Code	Misura Size	DN	Peso in kg. Weight in kg.	Dimensioni in mm Dimensions in mm			Foro Hole
				A	B	D	ØD mm
H245109	2"	50	0,50	80	155	110	6,0
H245110	2" 1/2	65	0,60	100	175	130	6,0
H245111	3"	80	1,00	125	200	145	6,0
H245112	4"	100	1,19	150	210	165	6,0
H245113	5"	125	1,62	180	240	195	6,0
H245114	6"	150	2,12	205	275	220	6,0
H245116	8"	200	3,10	255	330	275	6,0
H245118	10"	250	4,30	300	385	330	6,0

### Componenti e materiali / Components and materials

<b>Lamiera forata</b> / Perforated sheet	Acciaio zincato / Galvanized steel
<b>Flangia</b> / Flange	Acciaio zincato / Galvanized steel

M3

Modello / Model  
**FILTRO + PG**

Materiale / Material  
Aisi 304



### Caratteristiche tecniche / Construction features

- **Filtro di aspirazione con raccordo portagomma** / Suction filter with hose nipple
- **Connessione mediante raccordo portagomma** / Connection end with hose nipple
- **Anello per collegamento galleggiante** / Hook for float connection.
- **Grado di filtrazione** / Filtration  
U.S. mesh: 18 (10 per / for 2")
- **Trattamento superficiale: sgrassaggio, decapaggio ed elettrolucidatura** / Surface treatment: degreasing, pickling and electropolishing

### Dimensioni e pesi / Dimensions and weights

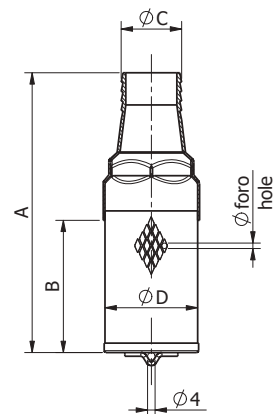

Codice Code	Misura Size	DN	Peso in gr. Weight in gr.	Dimensioni in mm Dimensions in mm				Foro rete Net hole
				A	B	Ø C	Ø D	Ø mm
800002	1"	25	110	150	70	26	49	1
800003L	1"1/4	32	130	195	110	32	49	1
800000L	1"1/2	40	215	240	140	38	60	1
800001L	2"	50	570	300	165	50	79	1.8







## Collettori

# Manifolds

- **I collettori sono utilizzati generalmente per collegare diversi segmenti di un impianto idraulico o per connettere due o più unità pompanti al fine di ottenere una maggiore portata d'acqua.** / Manifolds are generally used to connect different segments of a hydraulic system, or to connect two pump units to obtain a higher flow rate.
- **I collettori Mondeo sono realizzati in acciaio inox. Grazie allo spessore sottile, che aumenta la superficie interna di passaggio del fluido, e la saldatura a TIG delle parti filettate, si riducono al minimo le perdite di carico.** / Mondeo manifolds are made of stainless steel. Thanks to their slimness, which increases the inner flow surface of the fluid, and TIG-welded threaded parts, load losses are reduced to a minimum.
- **Oltre all'ottimo rendimento idraulico, altro punto di forza è la personalizzazione, sia per quanto riguarda le misure che la configurazione.** / In addition to their optimal hydraulic efficiency, another strong point of our manifolds is that both their size and their configuration can be personalised.
- **Sono adatti alla movimentazione di acqua sanitaria, in impianti di riscaldamento, per acqua potabile. Oltre che nel settore idrico-sanitario, sono utilizzati in impianti di depurazione delle acque o di trattamento di acque industriali. Possono essere utilizzati in edilizia negli impianti di riscaldamento a pavimento, per collegare in batteria contatori di acqua.** / These manifolds are suitable for transferring domestic hot water, in heating systems, for drinking water. In addition to the plumbing and drainage sector, they are used in water purification systems or for treating industrial water. They can be used in buildings for floor heating, for connecting water meters and for battery connecting water meters.
- **Per agevolare l'assemblaggio di gruppi di pompaggio sono disponibili kit contenenti le basi di appoggio per le pompe, i collettori, il supporto per il quadro elettrico, le valvole e tutti gli accessori necessari.** / To make pump group assembly easier, kits with the support bases for the pumps, the manifolds, the support for the electric panel, the valves and all the necessary accessories are available.

## Flange

# Flanges

- **Le flange sono ricavate da lamiera stampata, in acciaio inox con forature e dimensioni secondo normativa EN 1092-1. Sono disponibili con dimensioni da DN 25 a DN 100 e si distinguono per la loro leggerezza e resistenza. Possono essere filettate, maschio e femmina, a saldare o cieche, in acciaio zincato o in acciaio inox Aisi 304 e Aisi 316.** / Our flanges are made from pressed sheets of stainless steel. They are perforated and sized according to Standard EN 1092.1. They are available in sizes from DN 25 to DN 100 and stand out because of their lightness and resistance. Made of galvanized steel or Aisi 304 and Aisi 316, stainless steel they can be threaded, male and female, prepared for welding, or blind.
- **Sono disponibili anche confezionate con guarnizioni di tenuta, viti e dadi di chiusura. Per agevolare l'installazione di elettropompe idrauliche o valvole con bocche flangiate, è disponibile il kit flange che comprende le 2 controflange, guarnizioni, viti, dadi e rondelle.** / They are also available packed, with gaskets, screws and locknuts. To make it easier to install hydraulic motor pumps or valves with flanged inlets, a flange kit is available that contains 2 counterflanges, in addition to gaskets, screws, nuts and washers.

M4

# NEW DUAL / M 2P

**Collettori per gruppi di  
pressurizzazione / Manifolds  
for water booster units**

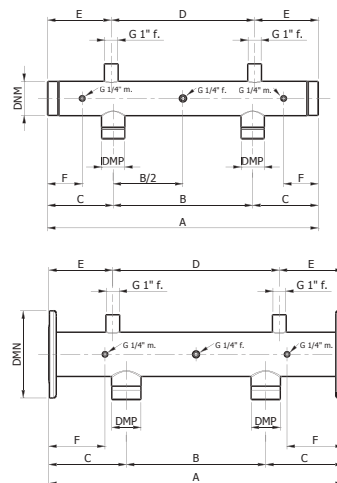

**Modello / Model**  
**M 2P**

**Materiale / Material**  
Aisi 304

**DN**  
40 – 100

**PN**  
16

## Caratteristiche tecniche / Construction features

- **Per gruppi a 2 pompe lato mandata /**  
For 2 pumps units, delivery side
- **Lavorazione mediante deformazione a  
freddo di tubo saldato /** Manufactured by  
cold collaring of welded pipes
- **Saldature a TIG senza apporto di  
materiale /** Welded joints made with TIG  
method without any additional material
- **Trattamento superficiale sgrassaggio,  
decapaggio ed elettrolucidatura /**  
Surface treatment degreasing, pickling and  
electropolishing
- **Connessioni filettate gas cilindriche  
secondo /** Threaded ends gas cilindric  
according to  
UNI ISO 228/1
- **Pressione nominale di esercizio /**  
Nominal working pressure  
16 bar

**Su richiesta /**  
**On request**



**Collettori in Aisi 316 /** Manifolds in Aisi 316  
**Elettrolucidatura interna dei collettori /**  
Internal electropolishing of manifolds

## Dimensioni e pesi / Dimensions and weights

Codice Code	DNM	DMP	Modello Model	PN	Peso in kg Weight in kg.	Dimensioni in mm Dimensions in mm					
						A	B	C	D	E	F
5M0001	1" 1/2 M	1" M	M 150/100	16	1,35	600	300	150	370	115	90
5M0006	2" M	1" M	M 200/100	16	1,60	600	300	150	370	115	90
5M0002	2" M	1" 1/4 M	M 200/125	16	1,65	600	300	150	370	115	90
5M0003	2" M	1" 1/2 M	M 200/150	16	1,67	600	300	150	370	115	90
5M0007	2" 1/2 M	1" 1/2 M	M 250/150	16	2,45	600	300	150	370	115	90
5M0004	3" M	1" 1/2 M	M 300/150	16	3,20	700	360	170	430	135	115
5M0005	3" M	2" M	M 300/200	16	3,40	600	300	150	370	115	90
5M0008	3" M	2" M	M 300/200	16	3,53	700	360	170	370	165	90
5M0018	DN100 *	2" 1/2 M	M 400/250	16	6,95	760	360	190	430	165	145

\* **Flange Stampate PN16 /** PN16 Flanges from pressed stainless steel

M4

# NEW DUAL / A 2P

**Collettori per gruppi di  
pressurizzazione** / Manifolds  
for water booster units

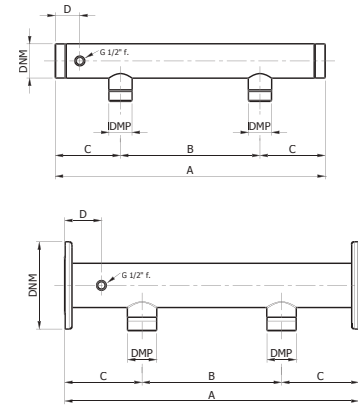

Modello / Model

A 2P

Materiale / Material

Aisi 304

DN

40 – 100

PN

16

## Caratteristiche tecniche / Construction features

- **Per gruppi a 2 pompe lato aspirazione** / For 2 pumps units, suction side
- **Lavorazione mediante deformazione a freddo di tubo saldato** / Manufactured by cold collaring of welded pipes
- **Saldature a TIG senza apporto di materiale** / Welded joints made with TIG method without any additional material
- **Trattamento superficiale sgrassaggio, decapaggio ed elettrolucidatura** / Surface treatment degreasing, pickling and electropolishing
- **Connessioni filettate gas cilindriche secondo** / Threaded ends gas cylindrical according to UNI ISO 228/1
- **Pressione nominale di esercizio** / Nominal working pressure 16 bar

**Su richiesta /  
On request**



**Collettori in Aisi 316** / Manifolds in Aisi 316  
**Elettrolucidatura interna dei collettori** /  
Internal electropolishing of manifolds

## Dimensioni e pesi / Dimensions and weights

Codice Code	DNM	DMP	Modello Model	PN	Peso in kg. Weight in kg.	Dimensioni in mm Dimensions in mm			
						A	B	C	D
5M0009	1" 1/2 M	1" M	A 150/100	16	1,20	600	300	150	65
5M0006A	2" M	1" M	A 200/100	16	1,40	600	300	150	65
5M0010	2" M	1" 1/4 M	A 200/125	16	1,50	600	300	150	65
5M0014	2" M	1" 1/2 M	A 200/150	16	1,60	600	300	150	65
5M0011	2" 1/2 M	1" 1/4 M	A 250/125	16	2,25	600	300	150	65
5M0012	2" 1/2 M	1" 1/2 M	A 250/150	16	2,30	600	300	150	65
5M0016	3" M	2" M	A 300/200	16	3,09	600	300	150	65
5M0013	3" M	2" M	A 300/200	16	3,38	700	360	170	65
5M0019	DN100 *	2" 1/2 M	A 400/250	16	6,70	760	360	200	100

\* **Flange Stampate PN16** / PN16 Flanges from pressed stainless steel

M4

# NEW DUAL / M 3P

**Collettori per gruppi di  
pressurizzazione / Manifolds  
for water booster units**

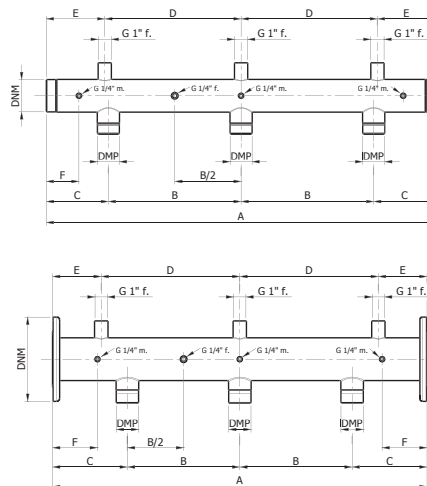

**Modello / Model**  
**M 3P**

**Materiale / Material**  
Aisi 304

**DN**  
50 – 100

**PN**  
16

## Caratteristiche tecniche / Construction features

- **Per gruppi a 3 pompe lato mandata / For 3 pumps units, delivery side**
- **Lavorazione mediante deformazione a freddo di tubo saldato / Manufactured by cold collaring of welded pipes**
- **Saldature a TIG senza apporto di materiale / Welded joints made with TIG method without any additional material**
- **Trattamento superficiale sgrassaggio, decapaggio ed elettrolucidatura / Surface treatment degreasing, pickling and electropolishing**
- **Connessioni filettate gas cilindriche secondo / Threaded ends gas cilindric according to UNI ISO 228/1**
- **Pressione nominale di esercizio / Nominal working pressure 16 bar**

**Su richiesta /  
On request**



**Collettori in Aisi 316 / Manifolds in Aisi 316**  
**Elettrolucidatura interna dei collettori /  
Internal electropolishing of manifolds**

## Dimensioni e pesi / Dimensions and weights

Codice Code	DNM	DMP	Modello Model	PN	Peso in kg. Weight in kg.	Dimensioni in mm Dimensions in mm					
						A	B	C	D	E	F
5M0006P	2" M	1" M	M 200/100	16	2,34	900	300	150	370	80	90
5M0002P	2" M	1" 1/4 M	M 200/125	16	2,34	900	300	150	370	80	90
5M0011MP	2" 1/2 M	1" 1/4 M	M 250/125	16	3,62	900	300	150	370	80	90
5M0007P	2" 1/2 M	1" 1/2 M	M 250/150	16	3,66	900	300	150	370	80	90
5M0004P	3" M	1" 1/2 M	M 300/150	16	4,69	900	300	150	370	80	90
5M0008P	3" M	2" M	M 300/200	16	5,09	1.060	360	170	370	160	90
5M0020	DN100 *	2" M	M 400/200	16	13,08	1.120	360	200	370	190	120

\* **Flange Stampate PN16 / PN16 Flanges from pressed stainless steel**

M4

# NEW DUAL / A 3P

**Collettori per gruppi di  
pressurizzazione** / Manifolds  
for water booster units

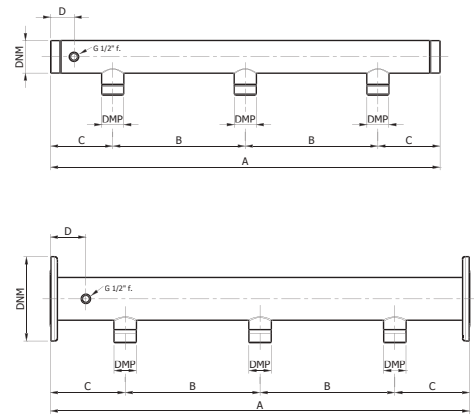

Modello / Model

A 3P

Materiale / Material

Aisi 304

DN

50 – 100

PN

16

## Caratteristiche tecniche / Construction features

- **Per gruppi a 3 pompe lato aspirazione** / For 3 pumps units, suction side
- **Lavorazione mediante deformazione a freddo di tubo saldato** / Manufactured by cold collaring of welded pipes
- **Saldature a TIG senza apporto di materiale** / Welded joints made with TIG method without any additional material
- **Trattamento superficiale sgrassaggio, decapaggio ed elettrolucidatura** / Surface treatment degreasing, pickling and electropolishing
- **Connessioni filettate gas cilindriche secondo** / Threaded ends gas cylindrical according to UNI ISO 228/1
- **Pressione nominale di esercizio** / Nominal working pressure 16 bar

**Su richiesta /  
On request**



**Collettori in Aisi 316** / Manifolds in Aisi 316  
**Elettrolucidatura interna dei collettori** / Internal electropolishing of manifolds

## Dimensioni e pesi / Dimensions and weights

Codice Code	DNM	DMP	Modello Model	PN	Peso in kg. Weight in kg.	Dimensioni in mm Dimensions in mm			
						A	B	C	D
5M0006AP	2" M	1" M	A 200/100	16	2,10	900	300	150	65
5M0010P	2" M	1" 1/4 M	A 200/125	16	2,15	900	300	150	65
5M0011P	2" 1/2 M	1" 1/4 M	A 250/125	16	3,50	900	300	150	65
5M0012P	2" 1/2 M	1" 1/2 M	A 250/150	16	3,80	900	300	150	65
5M0016P	3" M	2" M	A 300/200	16	4,80	900	300	150	65
5M0017P	3" M	1" 1/2 M	A 300/150	16	4,85	900	300	150	65
5M0013P	3" M	2" M	A 300/200	16	4,98	1.060	360	170	65
5M0021	DN100 *	2" M	A 400/200	16	12,77	1.120	360	200	100

\* Flange Stampate PN16 / PN16 Flanges from pressed stainless steel

M4

## NEW DUAL / CUSTOM

**Collettori per gruppi di pressurizzazione** / Manifolds for water booster units



Modello / Model

**CUSTOM**

Materiale / Material

Aisi 304 - Aisi 316

DN

25 – 200

PN

10 – 25

### Caratteristiche tecniche / Construction features

- **Collettori per gruppi di pressurizzazione** / manifolds for water booster units
- **Lavorazione mediante deformazione a freddo di tubo saldato** / Manufactured by cold collaring of welded pipes
- **Saldature a TIG senza apporto di materiale** / Welded joints made with TIG method without any additional material
- **Lunghezza massima** / Max. lenght: 1500 mm
- **Trattamento superficiale sgrassaggio, decapaggio ed elettrolucidatura** / Surface treatment degreasing, pickling and electropolishing
- **Conessioni** / Connections:
  - **Filettate gas cilindriche e coniche** / Threaded ends parallel and tapered gas
  - **NPT**
  - **Flangiate** / Flanged
  - **Victaulic**
  - **Clamp**

**Su richiesta /**  
On request



**Collettori in Aisi 316** / Manifolds in Aisi 316  
**Elettrolucidatura interna dei collettori** / Internal electropolishing of manifolds

M4

# CALOTTE STAMPATE

**Calotte femmina  
per collettori /**  
Female caps for  
manifolds

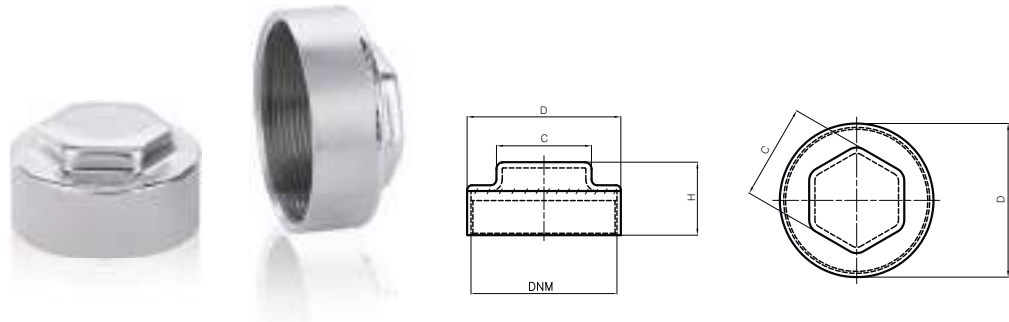

Modello / Model

**CALOTTE**

Materiale / Material

Aisi 304

DN

32 – 80

PN

16

## Caratteristiche tecniche / Construction features

- **Lavorazione per deformazione a freddo di lamiera del disco sagomato di chiusura** / Manufacturing by cold pressing of metal sheet of the shaped closing disc
- **Manicotto filettato ottenuto da tubi saldati** / Threaded connection obtained from welded pipes
- **Saldature a TIG senza apporto di materiale** / Welded joints made with TIG method without any additional material
- **Connessioni filettate gas cilindriche secondo** / Threaded ends gas cilindric according to UNI ISO 228/1
- **Trattamento superficiale sgrassaggio, decapaggio ed elettrolucidatura** / Surface treatment degreasing, pickling and electropolishing
- **Pressione nominale di esercizio** / Nominal working pressure  
16 bar

## Dimensioni e pesi / Dimensions and weights

Codice Code	Misura Size	DNM	DN	PN	Peso in gr. Weight in gr.	Dimensioni in mm Dimensions in mm		
						D	C	H
5CAL125	1" 1/4	1" 1/4 F	32	16	71	45	27	33
5CAL150	1" 1/2	1" 1/2 F	40	16	83	50,8	30	34
5CAL200	2"	2" F	50	16	122	63	41	35
5CAL250	2" 1/2	2" 1/2 F	65	16	222	80	50	39
5CAL300	3"	3" F	80	16	326	93	60	44

M4

## RIDUZIONI / MF

**Riduzioni filettate /**  
Threaded reductions

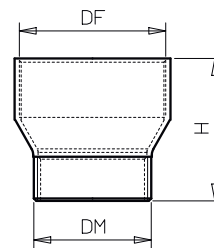

**Modello / Model**  
**RIDUZIONI MF**

**Materiale / Material**  
Aisi 304

**PN**  
16

### Caratteristiche tecniche / Construction features

- **Ottenuto da un tronchetto maschio deformato a freddo saldato con un manicotto** / Obtained by a shaped male nipple welded with a female socket
- **Saldature a TIG senza apporto di materiale** / Welded joints made with TIG method without any additional material
- **Conessioni filettate gas cilindriche secondo** / Threaded ends gas cylindrical according to UNI ISO 228/1
- **Trattamento superficiale sgrassaggio, decapaggio ed elettrolucidatura** / Surface treatment degreasing, pickling and electropolishing
- **Pressione nominale di esercizio** / Nominal working pressure 16 bar

### Dimensioni e pesi / Dimensions and weights

Codice Code	Misura DF Size DF	Misura DM Size DM	PN	Peso in gr. Weight in gr.	Dimensioni in mm Dimensions in mm
					H
902086M304	1" F	1" M	16	85	51
902088M304	1" 1/4 F	1" M	16	72	47
902090M304	1" 1/2 F	1" 1/4 M	16	101	47
902092M304	2" F	1" 1/2 M	16	147	57



M4

# NEW DUAL / WM

Collettori per  
contatori d'acqua /  
Manifolds for water  
meters

Versione ML / ML version



Versione BL / BL version

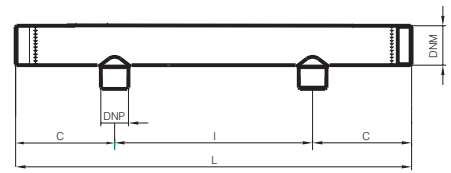

Modello / Model

NEW DUAL WM

Materiale / Material

Aisi 304

DN

40

PN

16

## Caratteristiche tecniche / Construction features

- **Ricavati da tubo saldato** / Manufactured from welded pipes
- **Saldature a TIG senza apporto di materiale** / Welded joints made with TIG method without any additional material
- **Trattamento superficiale sgrassaggio, decapaggio ed elettrolucidatura** / Surface treatment degreasing, pickling and electropolishing
- **Connesioni filettate gas cilindriche secondo** / Threaded ends gas cylindrical according to UNI ISO 228/1
- **Pressione nominale di esercizio** / Nominal working pressure 16 bar

### Su richiesta / On request

**Elettrolucidatura interna dei collettori** /  
Internal electropolishing of manifolds

\* **Altri interessi disponibili** /  
Other size available

## Dimensioni e pesi / Dimensions and weights

Codice Code	Versione Type	DNM	DNP	N. Uscite N. Outlets	Peso in kg. Weight in kg.	Dimensioni in mm Dimensions in mm			
						L	I	C	Spessore tubo Thickness
5CML40152	Mono laterale / Single side	1" 1/2 M	1/2" F	2	0,79	390	190 *	100	1,5
5CML40153		1" 1/2 M	1/2" F	3	1,10	580	190 *	100	1,5
5CML40154		1" 1/2 M	1/2" F	4	1,47	770	190 *	100	1,5
5CBL40154	Bilaterale / Double side	1" 1/2 M	1/2" F	4	0,83	390	190 *	100	1,5
5CBL40155		1" 1/2 M	1/2" F	6	1,22	580	190 *	100	1,5
5CBL40156		1" 1/2 M	1/2" F	8	1,62	770	190 *	100	1,5

M4

# MODUAL

Collettori modulari /  
Modular manifolds

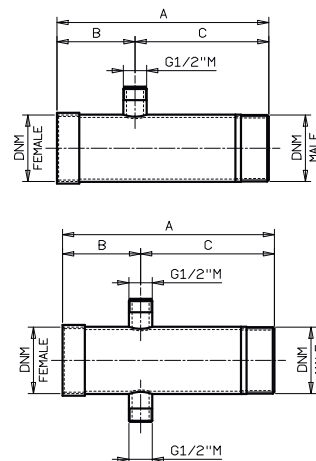

Modello / Model  
**MODUAL**

Materiale / Material  
Aisi 304

DN  
25 – 50

PN  
16

## Caratteristiche tecniche / Construction features

- **Ricavati da tubo saldato** / Manufactured from welded pipes
- **Saldature a TIG senza apporto di materiale** / Welded joints made with TIG method without any additional material
- **Trattamento superficiale sgrassaggio, decapaggio ed elettrolucidatura** / Surface treatment degreasing, pickling and electropolishing

- **Connessioni filettate gas cilindriche secondo** / Threaded ends gas cilindric according to UNI ISO 228/1
- **Pressione nominale di esercizio** / Nominal working pressure 16 bar

Su richiesta /  
On request



Collettori in Aisi 316 / Manifolds in Aisi 316

## Dimensioni e pesi / Dimensions and weights

Codice Code	Versione Type	DNM	Uscite Outlets	Peso in kg. Weight in kg.	Dimensioni in mm Dimensions in mm		
					A	B	C
5MDML100	Mono laterale / Single side	1" M / 1" F	1/2" M	0,28	190	70	120
5MDML125		1"1/4 M / 1"1/4 F	1/2" M	0,31	190	70	120
5MDML150		1"1/2 M / 1"1/2 F	1/2" M	0,35	190	70	120
5MDML200		2" M / 2" F	1/2" M	0,40	190	70	120
5MDBL100	Bilaterale / Double side	1" M / 1" F	1/2" M	0,30	190	70	120
5MDBL125		1"1/4 M / 1"1/4 F	1/2" M	0,33	190	70	120
5MDBL150		1"1/2 M / 1"1/2 F	1/2" M	0,37	190	70	120
5MDBL200		2" M / 2" F	1/2" M	0,42	190	70	120

MC4

# NEW HEAT / BL

**Collettori bilaterali  
semplici per impianti  
di riscaldamento /**  
Double sided simple  
manifolds for heating  
plants

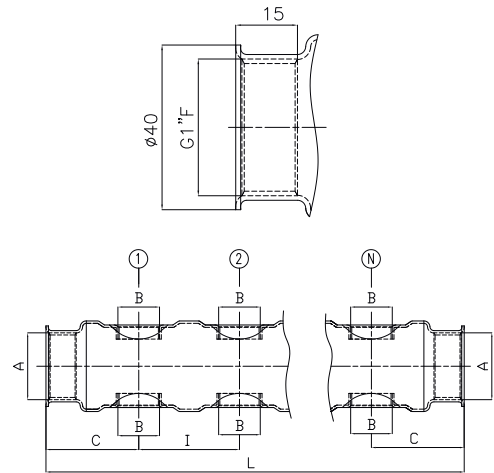

**Modello / Model**  
**NEW HEAT BL**

**Materiale / Material**  
Aisi 304

**DN**  
25

**PN**  
16

## Caratteristiche tecniche / Construction features

- **Lavorazione: deformazione a freddo del tubo** / Manufacturing process: pipes deformed by cold pressing
- **Saldature in bianco a TIG senza apporto di materiale** / Welded joints blank welding with TIG method without any additional material
- **Da 2 a 16 uscite filettate bilaterali da 1/2"** / From 2 up to 16 1/2" threaded connections on two sides
- **Trattamento superficiale sgrassaggio, decapaggio ed elettrolucidatura** / Surface treatment degreasing, pickling and electropolishing
- **Connessioni filettate gas cilindriche secondo** / Threaded ends gas cilindric according to UNI ISO 228/1
- **Pressione nominale di esercizio** / Nominal working pressure 16 bar

**Su richiesta /  
On request**

**Collettori in Aisi 316 / Manifolds in Aisi 316**

## Dimensioni e pesi / Dimensions and weights

Codice Code	Tubo principale Main pipe	A	B	N. Uscite N. Outlets	Peso in kg. Weight in kg.	Dimensioni in mm Dimensions in mm		
						C	I	L
5CBLN25152S	45 mm x 1,5 mm	1" F	1/2" F	2+2	0,22	45,5	50	141
5CBLN25153S	45 mm x 1,5 mm	1" F	1/2" F	3+3	0,28	45,5	50	191
5CBLN25154S	45 mm x 1,5 mm	1" F	1/2" F	4+4	0,36	45,5	50	241
5CBLN25155S	45 mm x 1,5 mm	1" F	1/2" F	5+5	0,45	45,5	50	291
5CBLN25156S	45 mm x 1,5 mm	1" F	1/2" F	6+6	0,48	45,5	50	341
5CBLN25157S	45 mm x 1,5 mm	1" F	1/2" F	7+7	0,60	45,5	50	391
5CBLN25158S	45 mm x 1,5 mm	1" F	1/2" F	8+8	0,66	45,5	50	441
5CBLN25159S	45 mm x 1,5 mm	1" F	1/2" F	9+9	0,77	45,5	50	491
5CBLN251510S	45 mm x 1,5 mm	1" F	1/2" F	10+10	0,77	45,5	50	541
5CBLN251511S	45 mm x 1,5 mm	1" F	1/2" F	11+11	0,93	45,5	50	591
5CBLN251512S	45 mm x 1,5 mm	1" F	1/2" F	12+12	1,00	45,5	50	641
5CBLN251513S	45 mm x 1,5 mm	1" F	1/2" F	13+13	1,03	45,5	50	691
5CBLN251514S	45 mm x 1,5 mm	1" F	1/2" F	14+14	1,11	45,5	50	741
5CBLN251515S	45 mm x 1,5 mm	1" F	1/2" F	15+15	1,18	45,5	50	791
5CBLN251516S	45 mm x 1,5 mm	1" F	1/2" F	16+16	1,26	45,5	50	841

M4

## KIT BASE / NEW

**Basi per gruppi di  
pressurizzazione  
a 2 pompe** / Bases  
for 2 pumps water  
booster units

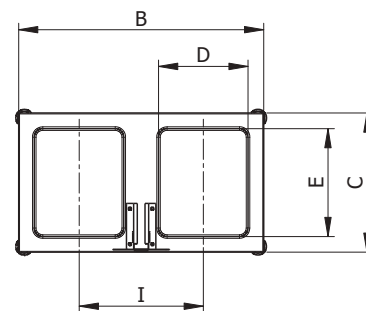
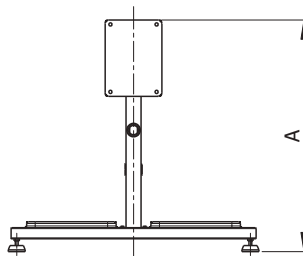

Modello / Model

KIT BASE NEW

Materiale / Material

Aisi 304

### Caratteristiche tecniche /

Construction features

- **Base e supporto quadro elettrico per gruppi di pressurizzazione a 2 pompe** / Base and control box support for 2 pumps water booster units
- **Forature eseguibili su richiesta** / Holes feasible on request

### Dimensioni e pesi /

Dimensions and weights

Codice Code	Peso in kg. Weight in kg.	Dimensioni in mm Dimensions in mm					
		A	B	C	D	E	I
5MOKITNEW	5,73	635	690	392	252	304	350

M4

## KIT BASE / ZNT

**Basi in acciaio  
zincato per gruppi di  
pressurizzazione a 2  
pompe** / Galvanized  
steel bases for 2 pumps

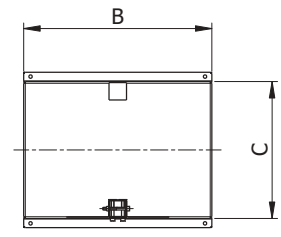
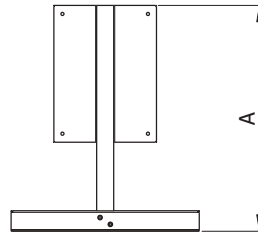

**Modello / Model**  
**KIT BASE ZNT**

**Materiale / Material**  
Acciaio zincato / Galvanized steel

### Caratteristiche tecniche / Construction features

- **Base e supporto quadro elettrico per gruppi di pressurizzazione a 2 pompe** / Base and control box support for 2 pumps water booster units
- **Forature eseguibili su richiesta** / Holes feasible on request

### Dimensioni e pesi / Dimensions and weights

Codice Code	Peso in kg. Weight in kg.	Dimensioni in mm Dimensions in mm		
		A	B	C
5MOKITZNT	11,45	668	550	430

M4

## KIT BASE / ZNT VER

**Base universale in acciaio zincato per gruppi di pressurizzazione a 1, 2 e 3 pompe verticali pluristadio**  
/ Galvanized steel multipurpose base for 1, 2 or 3 vertical multistage pumps pressurization units

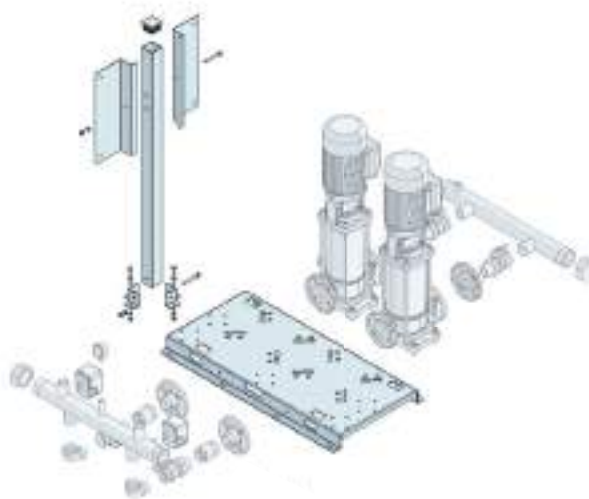

Modello / Model

KIT BASE ZNT VER

Materiale / Material

Acciaio zincato / Galvanized steel

### Caratteristiche tecniche / Construction features

- **Sistema versatile composto da base ed accessori per il montaggio di gruppi di pressurizzazione a 1,2 o 3 pompe verticali compatibile per l'installazione dei modelli di elettropompe dei principali costruttori di pompe (Lowara, Grundfos, Calpeda, Franklin, Stairs ecc...)** / Versatile system made up of base and accessories for setting up 1, 2 or 3 vertical pumps water booster units suitable for the installation of electropumps models of the main pumps manufacturers (Lowara, Grundfos, Calpeda, Franklin, Stairs etc...).
- **Forature: permettono il montaggio del quadro elettrico in posizioni differenziate (vedi disegni)** / Holes: allow the control box mounting in different positions (see drawings)
- **Con forature per sollevamento e trasporto con cinghie** / With holes for belts for easy lifting and transportation

### Sostegno quadro con posizionamento multiplo / Multiple control panel holder position

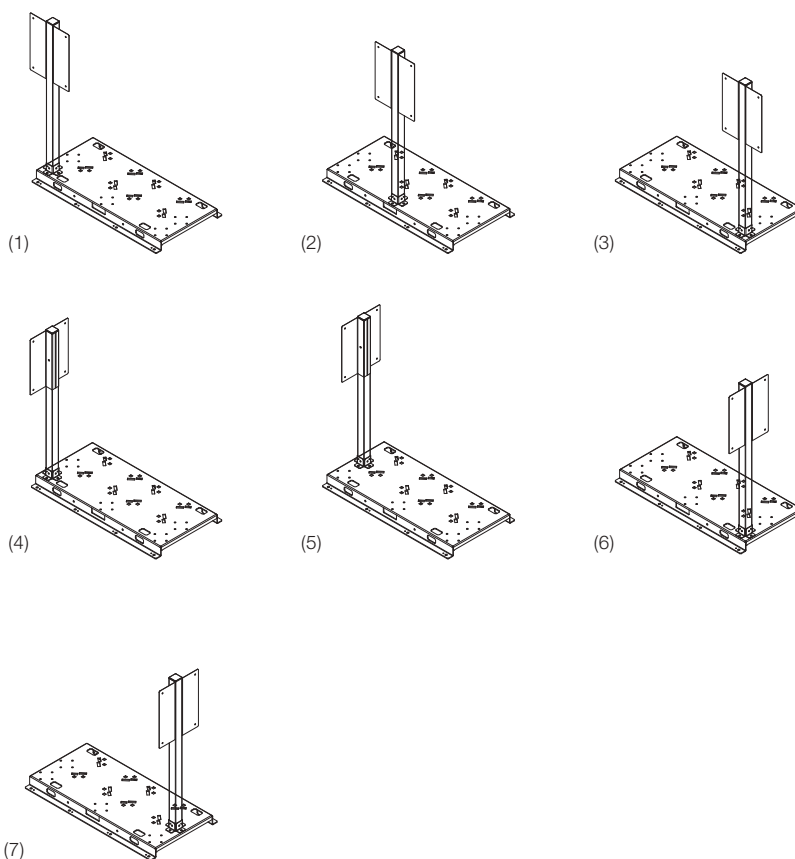

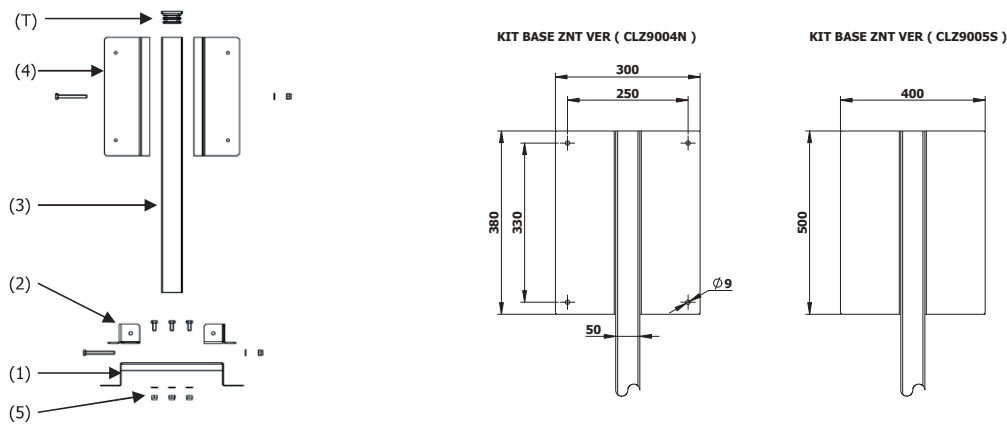

## Dimensioni e pesi / Dimensions and weights

Component Components	Codice Code	Misura Size	Caratteristiche Features	N. Pezzi necessari N. of pieces needed
<b>1 Base / Base</b>	5CLZ06L1920	530 x 396 mm	Per gruppi a 1 pompa fino a 4 kW / For single pompe units up to 4 kW	1
	5CLZ06L1921	560 x 418 mm	Per gruppi a 1 pompa fino a 22 kW / For single pompe units up to 22 kW	1
	5CLZ9002S	830 x 396 mm	Per gruppi a 2 pompe fino a 4 kW. Interasse pompe 300 mm / For units of 2 Pumps up to 4 kW. Pumps distance 300 mm	1
	5CLZ9001S	920 x 418 mm	Per gruppi a 2 pompe fino a 22 kW. Interasse pompe 360 mm / For units of 2 Pumps up to 22 kW. Pumps distance 360 mm	1
	5CLZ06L1918	1130 x 396 mm	Per gruppi a 3 pompe fino a 4 kW. Interasse pompe 300 mm / For units of 3 Pumps up to 4 kW. Pumps distance 300 mm	1
	5CLZ06L1919	1280 x 418 mm	Per gruppi a 3 pompe fino a 22 kW. Interasse pompe 360 mm / For units of 3 Pumps up to 22 kW. Pumps distance 360 mm	1
<b>2 Attacco base-tubolare / Base-pole connection</b>	5ATTBASECPT	<11kg	Quadri elettrici con peso fino a 10 kg / Control panels up to 10 kg weight	2
	5CLZ0003N	>11 kg <30 kg	Quadri elettrici con peso fino a 30 kg / Control panels up to 30 kg weight	2
<b>3 Tubolare di sostegno quadro / Support pole for control panel</b>	5CPZ9004N	H= 850 mm		1
	5CPZ9003N	H= 990 mm		1
	5CPZ9002N	H= 1180 mm		1
	5CPZ9001N	H= 1480 mm		1
<b>4 Supporto quadro / Control panel support</b>	5CLZ9004N	380 x 300 mm	Quadri elettrici 380 X 300 mm (interasse fori 330 x 250 mm) / 380 x 300 mm control panels (holes distance 330 x 250 mm)	2
	5CLZ9005S	500 x 400 mm	Quadri elettrici 500 X 400 mm (senza fori) / 500 x 400 mm control panels (without holes)	2
<b>5 Dadi in gabbia per fissaggio pompe alla base Cage nuts for pumps connection to the base</b>	DADOIGM83347	M8		4*
	DADOIGM103347	M10		4*
<b>T Tappo di chiusura / Closing Cap</b>	5ACP0001N	50 x 50 mm		1
<b>Viteria di fissaggio / Connection screws</b>	KITVIT01	<11 kg		1*
	KITVIT02	>11 kg <30 kg		1*

\* Per pompa / Each pumps

M4

# NEW DUAL HS

**Separatore idraulico multifunzionale /**  
Multifunctioning hydraulic separator



**Modello / Model**  
**NEW DUAL HS**

**Materiale / Material**  
Aisi 304

**DN**  
25 – 50

**PN**  
10

## Caratteristiche tecniche / Construction features

- **Ricavati da tubo saldato** / Manufactured from welded pipes
- **Saldature a TIG senza apporto di materiale** / Welded joints made with TIG method without any additional material
- **Trattamento superficiale sgrassaggio, decapaggio ed elettrolucidatura** / Surface treatment degreasing, pickling and electropolishing
- **Conessioni filettate gas cilindriche secondo** / Threaded ends gas cylindrical according to UNI ISO 228/1
- **Fluido impiegabile: acqua, acqua con glicole** / Working fluids: water, water with glycol (30% max)
- **Pressione max di esercizio** / Max working pressure 10 bar
- **Temperatura di esercizio** / Working temperature 0°C – +110°C

## Componenti e materiali / Components and materials

<b>1</b>	<b>Corpo</b> / Body	Acciaio inox / SS Aisi 304
<b>2</b>	<b>Valvola di sfiato</b> / Air vent	Ottone / Brass Aisi 304 SS (Modelli X / X models)
<b>3</b>	<b>Valvola di scarico</b> / Discharge valve	Ottone / Brass Aisi 316 SS (Modelli X / X models)
<b>4</b>	<b>Giunto di raccordo</b> / Connection coupling	Ghisa / Cast iron Aisi 304 SS (Modelli X / X models)
<b>5</b>	<b>Isolamento termico</b> / Thermal insulation	PE-X

## Funzionamento / Operating principle

- **Il Separatore idraulico multifunzionale Mondeo sopperisce alle anomalie che le portate o le prevalenze causano agli impianti, inoltre l'utilizzo dell'acciaio inox garantisce una minore dispersione termica rispetto ai tradizionali separatori in acciaio.** / The Mondeo multifunctional hydraulic separator compensates the abnormalities the flow or head causes on the plants. Furthermore the use of stainless steel guarantees minor heat loss compared to the traditional steel separators.
- **La particolare geometria gli permette di aver tre diverse caratteristiche:** / The particular shape allows it to have three different characteristics:
  - **Separazione idraulica** / Hydraulic separation
  - **Disaerazione** / De-aeration
  - **Defangazione** / Dirt separation

## Separazione idraulica / Hydraulic separation

- A Flusso in condizioni di equilibrio. Richiesta utenza pari alla capacità del generatore di acqua calda.** / Flow in equilibrium. Requested consumption is equal to hot water generator capacity
- B Flusso con richiesta utenza inferiore alla capacità del generatore. Una parte di acqua torna alla caldaia.** / Consumption requirement flow less than generator power. Some of the water goes back to the boiler.
- C Flusso con richiesta utenza superiore alla capacità del generatore. L'acqua di ritorno dall'utenza sopperisce alla richiesta.** / Consumption requirement flow higher than generator power. Water return from consumption satisfies the requirement.

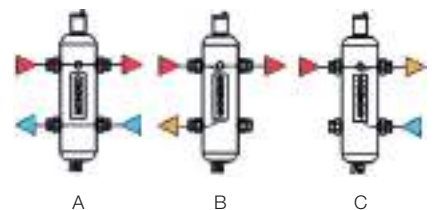



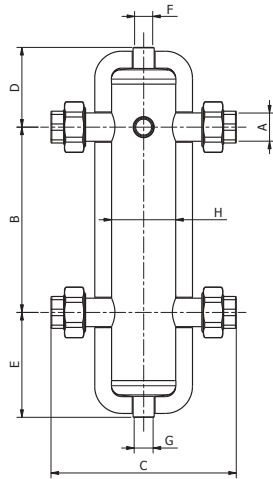

### Dimensioni e pesi / Dimensions and weights

Codice Code	Misura Size	Materiale raccordi Fittings material	DN	PN	Portata max. Max. flow m <sup>3</sup> /h	Volume (l)	Peso in kg. Weight in kg.	Dimensioni in mm Dimensions in mm							
								A	B	C	D	E	F	G	H
5SEPID100	1" F	Ottone-Ghisa / Brass-Cast iron	25	10	2,5	1,6	4,30	G1"	220	225	98	135	1/2"	1/2"	76,1
5SEPID125	1" 1/4 F		32	10	4	2,5	6,00	G1" 1/4	240	250	108	165	1/2"	1/2"	88,9
5SEPID150	1" 1/2 F		40	10	6	4,7	9,11	G1" 1/2	260	280	118	195	1/2"	1/2"	114,3
5SEPID200	2" F		50	10	8,5	8,3	13,00	G2"	300	315	128	225	1/2"	1/2"	139,7
5SEPID100X	1" F	Aisi 304	25	10	2,5	1,6	4,30	G1"	220	225	98	135	1/2"	1/2"	76,1
5SEPID125X	1" 1/4 F		32	10	4	2,5	6,00	G1" 1/4	240	250	108	165	1/2"	1/2"	88,9
5SEPID150X	1" 1/2 F		40	10	6	4,7	9,11	G1" 1/2	260	280	118	195	1/2"	1/2"	114,3
5SEPID200X	2" F		50	10	8,5	8,3	13,00	G2"	300	315	128	225	1/2"	1/2"	139,7

M4

# FLANGE / FLANGES CIECHE / BLIND

**Flange PN 16 in acciaio  
inox stampato** / Pressed  
stainless steel PN 16  
flanges

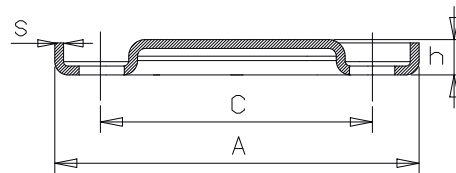

Modello / Model

**CIECHE / BLIND**

Materiale / Material

Aisi 304

DN

25 – 100

PN

16

## Caratteristiche tecniche /

### Construction features

- **Prodotte mediante deformazione a freddo di lamiera di acciaio inossidabile** / Manufactured by cold deformation of stainless steel sheet
- **Dimensioni secondo** / Dimensions according to EN 1092 /1 PN16
- **Fori ovali per facilitare l'assemblaggio** / Oval holes for easier assembling
- **Pressione nominale di esercizio** / Nominal working pressure 16 bar

### Su richiesta /

#### On request



**Acciaio inox Aisi 316 / SS Aisi 316**

## Dimensioni e pesi /

### Dimensions and weights

Codice Code	Misura Size	DN	PN	Peso in kg. Weight in kg.	Dimensioni in mm Dimensions in mm				N° fori N. holes	Diametro fori Diameter holes
					A	C	h	S		
200697C04ST	1"	25	16	0,33	115	85	16	3	4	14,5
200698C04ST	1" 1/4	32	16	0,47	140	100	16	3	4	18
200699C04ST	1" 1/2	40	16	0,53	150	110	16	3	4	18
200700C04ST	2"	50	16	0,84	165	125	16	4	4	18
200701C04ST	2" 1/2	65	16	1,03	185	145	18	4	4	18
200702C04ST	3"	80	16	1,22	200	160	18	4	8	18
200703C04ST	4"	100	16	1,75	225	180	19	5	8	18

M4

# FLANGE / FLANGES SCORREVOLI / LOOSE

**Flange scorrevoli PN 16  
in acciaio inox stampato /**  
Pressed stainless steel PN 16  
loose flanges

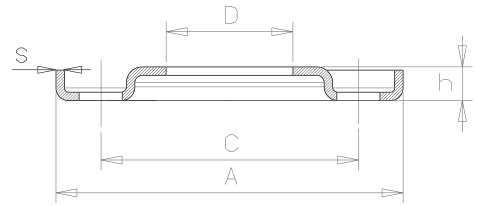

Modello / Model

**SCORREVOLI / LOOSE**

Materiale / Material

Aisi 304

DN

25 – 100

PN

16

## Caratteristiche tecniche / Construction features

- **Prodotte mediante deformazione a freddo di lamiera di acciaio inossidabile /**  
Manufactured by cold deformation of stainless steel sheet
- **Dimensioni secondo /**  
Dimensions according to  
EN 1092 /1 PN16
- **Fori ovali per facilitare l'assemblaggio /**  
Oval holes for easier assembling
- **Pressione nominale di esercizio /** Nominal  
working pressure  
16 bar

**Su richiesta /**  
On request



**Acciaio inox Aisi 316 / SS Aisi 316**

## Dimensioni e pesi / Dimensions and weights

Codice Code	Misura Size	DN	PN	Peso in kg. Weight in kg.	Dimensioni in mm Dimensions in mm					N° fori N. holes	Diametro fori Diameter holes
					A	C	D	h	S		
5MO300/304	1"	25	16	0,30	115	85	36	16	3	4	14,5
5MO301/304	1" 1/4	32	16	0,41	140	100	46	16	3	4	18
5MO302/304	1" 1/2	40	16	0,46	150	110	54	16	3	4	18
5MO303/304	2"	50	16	0,75	165	125	65	16	4	4	18
5MO304/304	2" 1/2	65	16	0,87	185	145	81	18	4	4	18
5MO305/304	3"	80	16	0,99	200	160	94	18	4	8	18
5MO306/304	4"	100	16	1,31	225	180	119	19	5	8	18

M4

# FLANGE / FLANGES MASCHIO / MALE

**Flange PN 16 con tronchetto maschio saldato** / Pressed stainless steel PN 16 flanges with welded male nipple

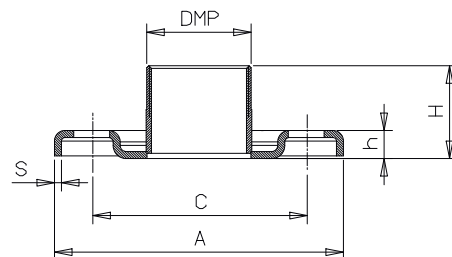

Modello / Model

**MASCHIO / MALE**

Materiale / Material

Aisi 304

DN

25 – 100

PN

16

## Caratteristiche tecniche / Construction features

- **Prodotte mediante deformazione a freddo di lamiera di acciaio inossidabile** / Manufactured by cold deformation of stainless steel sheet
- **Dimensioni secondo** / Dimensions according to EN 1092 /1 PN16
- **Filettatura controflange secondo** / Counterflanges threadings according to UNI ISO 228/1
- **Fori ovali per facilitare l'assemblaggio** / Oval holes for easier assembling
- **Pressione nominale di esercizio** / Nominal working pressure 16 bar

**Su richiesta /  
On request**



**Acciaio inox Aisi 316 / SS Aisi 316**

## Dimensioni e pesi / Dimensions and weights

Codice Code	Misura Size	DMP	DN	PN	Peso in kg. Weight in kg.	Dimensioni in mm Dimensions in mm					N° fori N. holes	Diametro fori Diameter holes
						A	C	H	h	S		
5MO320/304	1"	1" M	25	16	0,37	115	85	36,5	16	3	4	14,5
5MO321/304	1" 1/4	1" 1/4 M	32	16	0,53	140	100	41,5	16	3	4	18
5MO322/304	1" 1/2	1" 1/2 M	40	16	0,60	150	110	46,5	16	3	4	18
5MO323/304	2"	2" M	50	16	0,94	165	125	52,5	16	4	4	18
5MO324/304	2" 1/2	2" 1/2 M	65	16	1,20	185	145	62,5	18	4	4	18
5MO325/304	3"	3" M	80	16	1,45	200	160	72,5	18	4	8	18
5MO326/304	4"	4" M	100	16	2,17	225	180	83,5	19	5	8	18

M4

# FLANGE / FLANGES FEMMINA / FEMALE

**Flange PN 16 con  
manicotto femmina  
saldato** / Pressed  
stainless steel PN16  
flanges with welded  
female socket

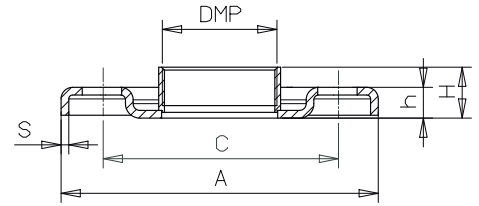

Modello / Model

**FEMMINA / FEMALE**

Materiale / Material

Aisi 304 - Acciaio zincato / Zinc plated steel

DN

25 – 100

PN

16

## Caratteristiche tecniche / Construction features

- **Prodotte mediante deformazione a freddo di lamiera di acciaio inossidabile** / Manufactured by cold deformation of stainless steel sheet
- **Versioni in acciaio zincato prodotte mediante stampaggio a caldo** / Version in galvanized steel manufactured by hot forming
- **Dimensioni secondo** / Dimensions according to EN 1092 /1 PN16
- **Filettatura controflange secondo** / Counterflanges threadings according to UNI ISO 228/1
- **Fori ovali per facilitare l'assemblaggio** / Oval holes for easier assembling
- **Pressione nominale di esercizio** / Nominal working pressure 16 bar

**Su richiesta /  
On request**

**Acciaio inox Aisi 316 / SS Aisi 316**

## Dimensioni e pesi / Dimensions and weights

Codice Code	Misura Size	DMP	Materiale Material	DN	PN	Peso in kg. Weight in kg.	Dimensioni in mm Dimensions in mm					N° fori N. holes	Diametro fori Diameter holes
							A	C	H	h	S		
5MO340N/304	1"	1" F	Aisi 304	25	16	0,32	115	85	19	16	3	4	14,5
5MO341N/304	1" 1/4	1" 1/4 F		32	16	0,46	140	100	22	16	3	4	18
5MO342N/304	1" 1/2	1" 1/2 F		40	16	0,53	150	110	22	16	3	4	18
5MO343N/304	2"	2" F		50	16	0,80	165	125	25,5	16	4	4	18
5MO344N/304	2" 1/2	2" 1/2 F		65	16	1,24	185	145	57,5	18	4	4	18
5MO345N/304	3"	3" F		80	16	1,48	200	160	64,5	18	4	8	18
5MO346N/304	4"	4" F		100	16	2,23	225	180	73,5	19	5	8	18
5MO340N/ZNT	1"	1" F	Acciaio zincato / Galvanized steel	25	16	0,44	115	85	16	10	5	4	14
5MO341N/ZNT	1" 1/4	1" 1/4 F		32	16	0,64	140	100	16	13	5	4	18
5MO342N/ZNT	1" 1/2	1" 1/2 F		40	16	0,76	150	110	19	14	5	4	18
5MO343N/ZNT	2"	2" F		50	16	0,99	165	125	24	16	5	4	18
5MO344N/ZNT	2" 1/2	2" 1/2 F		65	16	1,23	185	145	23	16	7	4	18
5MO345N/ZNT	3"	3" F		80	16	1,32	200	160	27	17	8	8	18
5MO346N/ZNT	4"	4" F		100	16	1,59	225	180	31	18	8	8	18

M4

## KIT CONTROFLANGE / KIT COUNTERFLANGES STANDARD

**Kit con 2 controflange  
femmina** / Kits made up of  
2 female counterflanges



Modello / Model

**KIT STANDARD**

Materiale / Material

Acciaio inox - acciaio zincato / Stainless steel - galvanized steel

DN

25 – 100

### Caratteristiche tecniche / Construction features

- **KIT composto da 2 controflange femmina, 2 guarnizioni e viteria in imballo singolo** / KIT made of 2 x female counterflanges, 2 x gaskets, nuts and bolts in one carton
- **Filettatura controflange secondo** / Counterflanges threadings according to UNI ISO 228/1
- **Spessore guarnizioni** / Gaskets thickness 2 mm

### Componenti e materiali / Components and materials

#### Flange / Flanges

Acciaio zincato, acciaio inox Aisi 304 o Aisi 316 /  
Galvanized steel, stainless steel Aisi 304 or Aisi 316

#### Guarnizioni / Gaskets

Fibre aramidiche con gomma NBR, esente da amianto  
(indicato per acqua potabile) / Aramid fibers bounded  
with NBR rubber asbestosfree (suitable to drinkable  
water)

#### Materiale viti, dadi e rondelle / Screws, bolts and nuts

Acciaio zincato (Aisi 316 per versione con flange in Aisi  
316) / Galvanized steel (stainless steel Aisi 316 only for  
version with Aisi 316 flanges)

**Dimensioni e pesi /**  
**Dimensions and weights**

<b>Codice</b> Code	<b>Misura</b> Size	<b>Materiale</b> <b>controflange</b> Counterflanges material	<b>Materiale</b> <b>viteria</b> Nuts and bolts material	<b>DN</b>	<b>Flange</b> Flanges	<b>Guarnizioni</b> Gaskets	<b>Viti, dadi e</b> <b>rondelle</b> Bolts and nuts
5MH4672/ZNTVZ	1"	Acciaio zincato / Galvanized steel	Acciaio zincato / Galvanized steel	25	2 x DN 25	2 x DN 25	8 x M12
5MH4673/ZNTVZ	1" 1/4			32	2 x DN 32	2 x DN 32	8 x M16
5MH4674/ZNTVZ	1" 1/2			40	2 x DN 40	2 x DN 40	8 x M16
5MH4675/ZNTVZ	2"			50	2 x DN 50	2 x DN 50	8 x M16
5MH4676/ZNTVZ	2" 1/2			65	2 x DN 65	2 x DN 65	8 x M16
5MH4677/ZNTVZ	3"			80	2 x DN 80	2 x DN 80	16 x M16
5MH4678/ZNTVZ	4"			100	2 x DN 100	2 x DN 100	16 x M16
5MH4672/304VZ	1"			Aisi 304	Acciaio zincato / Galvanized steel	25	2 x DN 25
5MH4673/304VZ	1" 1/4	32	2 x DN 32			2 x DN 32	8 x M16
5MH4674/304VZ	1" 1/2	40	2 x DN 40			2 x DN 40	8 x M16
5MH4675/304VZ	2"	50	2 x DN 50			2 x DN 50	8 x M16
5MH4676/304VZ	2" 1/2	65	2 x DN 65			2 x DN 65	8 x M16
5MH4677/304VZ	3"	80	2 x DN 80			2 x DN 80	16 x M16
5MH4678/304VZ	4"	100	2 x DN 100			2 x DN 100	16 x M16
5MH4672/316	1"	Aisi 316	Aisi 316			25	2 x DN 25
5MH4673/316	1" 1/4			32	2 x DN 32	2 x DN 32	8 x M16
5MH4674/316	1" 1/2			40	2 x DN 40	2 x DN 40	8 x M16
5MH4675/316	2"			50	2 x DN 50	2 x DN 50	8 x M16
5MH4676/316	2" 1/2			65	2 x DN 65	2 x DN 65	8 x M16
5MH4677/316	3"			80	2 x DN 80	2 x DN 80	16 x M16
5MH4678/316	4"			100	2 x DN 100	2 x DN 100	16 x M16

M4

## KIT CONTROFLANGE / KIT COUNTERFLANGES EN 733

**Kit controflange completi di viteria e guarnizioni per elettropompe centrifughe normalizzate secondo EN 733 /**

Counterflanges kit for end suction centrifugal pumps according to en 733



**Modello / Model**

**KIT EN 733**

**Materiale / Material**

Acciaio inox - acciaio zincato / Stainless steel - galvanized steel

**DN**

25 – 100

### Caratteristiche tecniche / Construction features

- **KIT composto da 2 controflange femmina, 2 guarnizioni e viteria in imballo singolo** / KIT made of 2 x female counterflanges, 2 x gaskets, nuts and bolts in one carton
- **Filettatura controflange secondo** / Counterflanges threadings according to UNI ISO 228/1
- **Spessore guarnizioni** / Gaskets thickness 2 mm

### Componenti e materiali / Components and materials

#### Flange / Flanges

Acciaio zincato, acciaio inox Aisi 304 o Aisi 316 / Galvanized steel, stainless steel Aisi 304 or Aisi 316

#### Guarnizioni / Gaskets

Fibre aramidiche con gomma NBR, esente da amianto (indicato per acqua potabile) / Aramid fibers bounded with NBR rubber asbestosfree (suitable to drinkable water)

#### Materiale viti, dadi e rondelle / Screws, bolts and nuts

Acciaio zincato (Aisi 316 per versione con flange in Aisi 316) / Galvanized steel (stainless steel Aisi 316 only for version with Aisi 316 flanges)



**Dimensioni e pesi /**  
**Dimensions and weights**

<b>Codice</b> Code	<b>Misura</b> Size	<b>Materiale</b> <b>controflange</b> Counterflanges material	<b>Materiale</b> <b>viteria</b> Nuts and bolts material	<b>DN</b>	<b>Flange</b> Flanges	<b>Guarnizioni</b> Gaskets	<b>Viti, dadi e</b> <b>rondelle</b> Bolts and nuts
5MNH4672/ZNTVZ	1"	Acciaio zincato / Galvanized steel	Acciaio zincato / Galvanized steel	25	1 x DN 25	1 x DN 25	4 x M12
					1 x DN 50	1 x DN 50	4 x M16
5MNH4673/ZNTVZ	1" 1/4			32	1 x DN 32	1 x DN 32	4 x M16
					1 x DN 50	1 x DN 50	4 x M16
5MNH4674/ZNTVZ	1" 1/2			40	1 x DN 40	1 x DN 40	4 x M16
					1 x DN 65	1 x DN 65	4 x M16
5MNH4675/ZNTVZ	2"			50	1 x DN 50	1 x DN 50	4 x M16
					1 x DN 65	1 x DN 65	4 x M16
5MNH4676/ZNTVZ	2" 1/2			65	1 x DN 65	1 x DN 65	4 x M16
					1 x DN 80	1 x DN 80	8 x M16
5MNH4677/ZNTVZ	3"			80	1 x DN 80	1 x DN 80	8 x M16
					1 x DN 100	1 x DN 100	8 x M16
5MNH4672/304VZ	1"	Aisi 304	Acciaio zincato / Galvanized steel	25	1 x DN 25	1 x DN 25	4 x M12
					1 x DN 50	1 x DN 50	4 x M16
5MNH4673/304VZ	1" 1/4			32	1 x DN 32	1 x DN 32	4 x M16
					1 x DN 50	1 x DN 50	4 x M16
5MNH4674/304VZ	1" 1/2			40	1 x DN 40	1 x DN 40	4 x M16
					1 x DN 65	1 x DN 65	4 x M16
5MNH4675/304VZ	2"			50	1 x DN 50	1 x DN 50	4 x M16
					1 x DN 65	1 x DN 65	4 x M16
5MNH4676/304VZ	2" 1/2			65	1 x DN 65	1 x DN 65	4 x M16
					1 x DN 80	1 x DN 80	8 x M16
5MNH4677/304VZ	3"			80	1 x DN 80	1 x DN 80	8 x M16
					1 x DN 100	1 x DN 100	8 x M16
5MNH4672/316	1"	Aisi 316	Aisi 316	25	1 x DN 25	1 x DN 25	4 x M12
					1 x DN 50	1 x DN 50	4 x M16
5MNH4673/316	1" 1/4			32	1 x DN 32	1 x DN 32	4 x M16
					1 x DN 50	1 x DN 50	4 x M16
5MNH4674/316	1" 1/2			40	1 x DN 40	1 x DN 40	4 x M16
					1 x DN 65	1 x DN 65	4 x M16
5MNH4675/316	2"			50	1 x DN 50	1 x DN 50	4 x M16
					1 x DN 65	1 x DN 65	4 x M16
5MNH4676/316	2" 1/2			65	1 x DN 65	1 x DN 65	4 x M16
					1 x DN 80	1 x DN 80	8 x M16
5MNH4677/316	3"			80	1 x DN 80	1 x DN 80	8 x M16
					1 x DN 100	1 x DN 100	8 x M16

M1

## SKORA

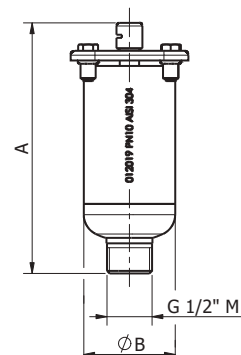
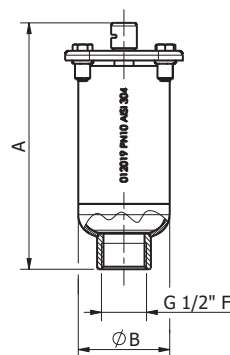
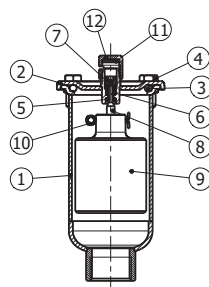
Valvola di sfiato /  
Air ventModello / Model  
**SKORA**Materiale / Material  
Aisi 304Tenuta / Seal  
FPMDN  
15PN  
10Caratteristiche tecniche /  
Construction features

- **Conessioni filettate femmina e maschio secondo** / Threaded ends female and male according to UNI ISO 228/1
- **Saldatura a TIG senza apporto di materiale** / TIG weldings without additional material
- **Trattamento superficiale sgrassaggio, decapaggio ed elettrolucidatura** / Surface treatment degreasing, pickling and electropolishing
- **Test idraulico di tenuta guarnizioni** / Hydraulic test on the seal rings 1.5 bar
- **Pressione nominale di esercizio** / Nominal working pressure 10 bar
- **Pressione massima di scarico** / Maximum discharge pressure 2.5 bar
- **Temperatura massima di esercizio** / Maximum working temperature max 100 °C

Componenti e materiali /  
Components and materials

1	<b>Corpo</b> / Body	Acciaio inox / SS Aisi 304
2	<b>Coperchio</b> / Cover	Acciaio inox / SS Aisi 304
3	<b>Guarnizione OR</b> / Seal ring	FPM
4	<b>Vite TE M5</b> / TE M5 screw (4 x)	Acciaio inox / SS Aisi 304
5	<b>Guarnizione OR</b> / Seal ring	FPM
6	<b>Molla</b> / Spring	Acciaio inox / SS Aisi 304
7	<b>Guida spillo</b> / Pin guide	Poliamide / Polyamide 6
8	<b>Spillo</b> / Pin	Acciaio inox / SS Aisi 304
9	<b>Galleggiante</b> / Float	Polipropilene / Polypropylene
10	<b>Copiglia di bloccaggio</b> / Locking pin	Acciaio inox / SS Aisi 304
11	<b>Guarnizione piana</b> / Flat seat	FPM
12	<b>Tappo di chiusura</b> / Closing cap	Acciaio inox / SS Aisi 304

Dimensioni e pesi /  
Dimensions and weights

Codice Code	Tipo Type	DN	PN	Peso in gr. Weight in gr.	Dimensioni in mm Dimensions in mm	
					A	B
900480	1/2" F	15	10	315	114	42
900481	1/2" M	15	10	350	116	42



## Serbatoi

### Pressurized tanks

- **Si tratta di serbatoi a membrana che hanno la funzione di accumulare una riserva di fluido in pressione all'interno di un impianto idraulico e consentono di regolare l'erogazione o la pressione del fluido. L'involucro dei serbatoi è realizzato in acciaio Aisi 304 e le membrane in EPDM o butile.** / The tanks are separated by a membrane that accumulate a reserve of pressurised fluid in a hydraulic system and make it possible to adjust fluid supply or pressure. The tank exterior is made of Aisi 304 steel and the membranes of EPDM or butyl.
- **La capacità del serbatoio va da 0,16 l a 500 l, la pressione massima di funzionamento è di 15 bar e la temperatura massima di 100 °C, a seconda dei modelli.** / Tank capacities range from 0.16 to 500 litres, the maximum working pressure is 15 bar and the maximum temperature 100 °C according to the model.
- **Sono adatti in ambito domestico, per impianti autoclave e di riscaldamento, in ambito industriale per applicazioni in ambienti corrosivi. Sono utilizzati in impianti autoclave, per ovviare ai ripetuti avvii ed arresti delle elettropompe, per ammortizzare i colpi di ariete e quindi proteggere l'impianto dalla sovrappressione di chiusura, per abolire le variazioni di pressione dovute al dilatarsi del fluido in seguito all'aumento di temperatura (funzione di vaso d'espansione).** / Suitable for domestic environments, autoclave and heating systems, in industry for applications in corrosive environments. Used in autoclave systems to counter repeated motor pump starts and stops, to dampen water hammers and so protect the system from overpressure caused by closure, and to eliminate the variations in pressure caused by fluid expansion following an increase in temperature (expansion tank function).

M4

# IDROBAR / M - A

Idroaccumulatori /  
Pressurized tank

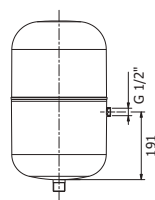

A 24

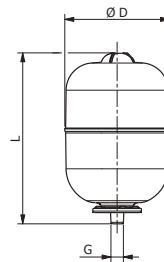

8 - 24 l

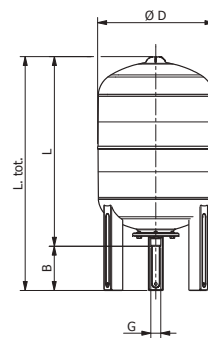

50 - 750 l

Modello / Model

IDROBAR / M - A

Materiale / Material

Aisi 304

PN

8 - 10

## Caratteristiche tecniche / Construction features

- **Pressione nominale di esercizio /**  
Nominal working pressure  
10 bar (8 bar M 750)
- **Temperatura di esercizio /**  
Working temperature  
0°C - +90°C
- **Prearica di fabbrica /** Precharge  
pressure-set by factory  
2,0 bar
- **Impieghi: impianti autoclave per uso  
industriale, alimentare e chimico;  
impianti di riscaldamento; impianti a  
pannelli solari /** Applications: water booster  
systems for industrial, food and chemical  
industry; heating systems; solar panel systems
- **Modello A24 senza membrana per impiego  
con alimentatore d'aria /** A24 model without  
diaphragm for use with air feeder
- **Attacco alimentatore /** Air feeder connection  
1/2" F
- **Installazione verticale /** Vertical installation

## Componenti e materiali / Components and materials

<b>Involucro esterno, flangia e controflangia /</b> External casing, flange and counterflanges	Lamiera in acciaio inox / Stainless steel sheet Aisi 304
<b>Membrana interna /</b> Diaphragm	EPDM impermeabile / Waterproof, non-toxic, EPDM rubber
<b>Staffe di assemblaggio e viti /</b> Support brackets for assembly and screws	Acciaio inox / SS Aisi 304

## Dimensioni e pesi / Dimensions and weights

Codice Code	Modello Type	Capacità lt Capacity lt	G	Peso in kg. Weight in kg.	Dimensioni in mm Dimensions in mm				
					ØD	L	Ltot	B	Imballo Packing
600009	A 24*	24	1"	3,65	268	480	-	-	280 x 280 x 520
600001N	M 8	8	3/4"	1,98	210	330	-	-	225 x 225 x 340
600004N	M 24*	24	1"	4,32	268	510	-	-	280 x 280 x 520
600012V	M 50*	50	1"	8,20	365	-	732	140	380 x 400 x 760
600014	M 100*	100	1"	18,00	500	-	820	120	510 x 530 x 830
600017	M 200	200	1" 1/4	55,00	550	-	1200	200	600 x 600 x 1400
600018	M 300	300	1" 1/4	80,00	650	-	1300	240	700 x 800 x 1500
600019	M 500	500	1" 1/4	105,00	750	-	1550	240	800 x 900 x 1700
600023	M 750	750	1" 1/4	140	750	-	2100	240	800 x 900 x 2200

\* Disponibile /  
Available



### KIT ANTI-LEGIONELLA

**Prolunga /** Extension **902086M304**  
1" F / 1" M (p. 128)  
+ **FLOWTHRU IFP-100B** (p. 100)



M4

# IDROBAR / MO

**Idroaccumulatori /**  
Pressurized tank

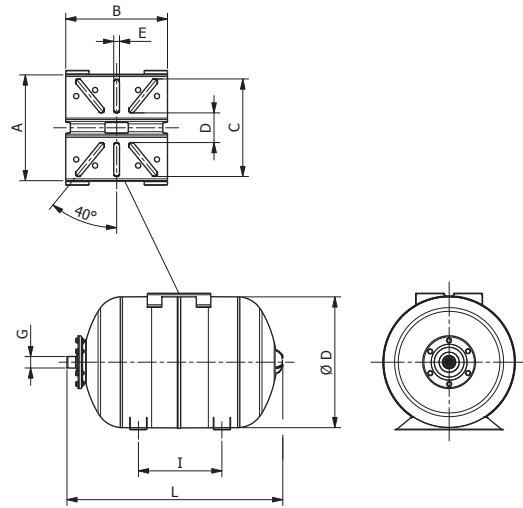

**Modello / Model**  
**IDROBAR / MO**

**Materiale / Material**  
Aisi 304

**PN**  
10

## Caratteristiche tecniche / Construction features

- **Pressione nominale di esercizio / Nominal working pressure**  
10 bar
- **Temperatura di esercizio / Working temperature**  
0°C – +90°C
- **Precarica di fabbrica / Precharge pressure-set by factory**  
2,0 bar
- **Impieghi: impianti autoclave per uso industriale, alimentare e chimico; impianti di riscaldamento; impianti a pannelli solari**  
Applications: water booster systems for industrial, food and chemical industry; Heating systems; solar panel systems
- **Impiego orizzontale con staffaggio fisso / Horizontal installation with welded bracket system**

## Componenti e materiali / Components and materials

<b>Involucro esterno, flangia e controflangia /</b> External casing, flange and counterflanges	Lamiera in acciaio inox / Stainless steel sheet Aisi 304
<b>Membrana interna /</b> Diaphragm	EPDM impermeabile / Waterproof, non-toxic, EPDM rubber
<b>Staffe di assemblaggio e viti /</b> Support brackets for assembly and screws	Acciaio inox / Stainless steel Aisi 304

## Dimensioni e pesi / Dimensions and weights

Codice Code	Modello Type	Capacità lt Capacity lt	G	Peso in kg. Weight in kg.	Dimensioni in mm Dimensions in mm								Imballo Packing
					ØD	L	I	A	B	C	D	E	
600005N	MO 24	24	1"	6,0	265	510	250	184	175	168	51	10,5	280 x 280 x 510
600012	MO 50	50	1"	8,8	365	590	250	184	175	168	51	10,5	380 x 400 x 600
600014OR	MO 100	100	1"	18	500	710	250	184	175	168	51	10,5	510 x 530 x 720

M4

## IDROBAR / WH

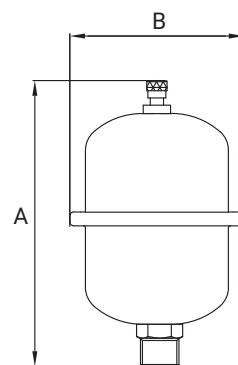
Anti-colpo d'ariete /  
Shock arrestor

Modello / Model

IDROBAR / WH

Materiale / Material

Aisi 304

PN

10 – 15

Caratteristiche tecniche /  
Construction features

- **Raccordo idraulico** / Water connection  
1/2" gas
- **Capacità disponibili** / Available capacity  
0.16, 0.5, 1, 2 litri/lt
- **Pressione massima di esercizio** /  
Maximum working pressure  
15 bar (per modello / for model  
M016)  
10 bar (per modello / for model  
M05, M1, M2)
- **Temperatura di esercizio** / Working  
temperature  
-10°C – +90°C
- **Precarica di fabbrica** / Precharge  
pressure-set by factory  
3,5 bar

Su richiesta /  
On requestMembrana con certificazione WRAS /  
WRAS approved diaphragmComponenti e materiali /  
Components and materials

<b>Involucro esterno e raccordo idraulico</b> / External body and water connection	Acciaio inox / SS Aisi 304
---	----------------------------

<b>Membrana interna</b> / Internal diaphragm	Butile / Butyl
--	----------------

<b>Valvola</b> / Valve	Ottone nichelato / Nickel-plated brass
------------------------	--

Dimensioni e pesi /  
Dimensions and weights

Codice Code	Modello Type	Capacità lt Capacity lt	Peso in kg. Weight in kg.	Dimensioni in mm Dimensions in mm	
				A	B
600016	M016	0.16 lt	0,25	110	78
600020	M05	0.5 lt	0,38	157	95
600021	M1	1 lt	0,55	188	114
600022	M2	2 lt	0,81	225	136

M5

# MEMBRANE / DIAPHRAGMS

**Per idroaccumulatori /**  
For pressurized tanks



**Modello / Model**

**MEMBRANE**

**Materiale / Material**

EPDM

**LT**

8-100

## Caratteristiche tecniche / Construction features

- **Membrane di ricambio /** Replacement membrane
- **Temperatura massima di esercizio /** Maximum working temperature 90°C

## Componenti e materiali / Components and materials

**Materiale / Material**

EPDM

## Dimensioni / Dimensions

<b>Codice</b> Code	<b>Materiale</b> Material	<b>Capacità lt</b> Capacity lt
500054	EPDM	8
500055	EPDM	24
500056	EPDM	50
500057	EPDM	100
500062	EPDM	200
500059	EPDM	300
500063	EPDM	500
500064	EPDM	750







## Accessori per idraulica

### Hydraulic equipment

- **Mondeo seleziona e produce gli accessori idraulici più richiesti per le diverse esigenze di un impianto idraulico: manometri, pressostati, pressoflussostati, alimentatori automatici ad aria, membrane di ricambio per serbatoi, galleggianti verticali e orizzontali, tubi flessibili, raccordi speciali per pozzi artesiani.**

Mondeo selects and produces those hydraulic accessories that are needed most for the different requirements of a hydraulic system: pressure gauges, pressure switches, air-powered automatic feeders, spare membranes for tanks, vertical and horizontal floats, flexible hoses, special pipe fittings for artesian aquifers.

M5

# MANOMETRI / PRESSURE GAUGES / Ø 53

Manometri a secco /  
Dry pressure gauges



Versione con  
indicatore rosso /  
Red index version

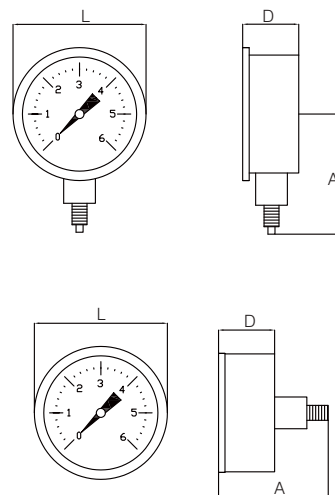

Modello / Model  
Ø 53

Materiale cassa / Casing material  
ABS

Attacco / Connection  
Ottone / Brass

## Caratteristiche tecniche / Construction features

- **Manometri a molla di Bourdon** / Bourdon spring pressure gauges
- **Misura** / Size  
Ø 53
- **Doppia scala** / Double scale  
bar / psi
- **Scale disponibili** / Available scales  
0-6 / 10 / 16 bar

## Componenti e materiali / Components and materials

<b>Cassa</b> / Casing	ABS nero / black
<b>Meccanismo</b> / Mechanism	Ottone / Brass
<b>Attacco</b> / Connection	Ottone (1/4" M gas) / Brass (1/4" M gas)
<b>Vetro</b> / Glass	Acilico / Acrylic

## Dimensioni e pesi / Dimensions and weights

Codice Code	Versione Type	Caratteristiche Features	Scala Scale		Peso in gr. Weight in gr.	Dimensioni in mm Dimensions in mm		
			bar	psi		A	L	D
600200	Ø 53	Attacco radiale Bottom connection	0 - 6	0 - 90	64	47	53	27
600201			0 - 10	0 - 150	64	47	53	27
600202			0 - 16	0 - 240	64	47	53	27
600250	Ø 53	Attacco posteriore Rear connection	0 - 6	0 - 90	68	47	53	27
600251			0 - 10	0 - 150	68	47	53	27
600252			0 - 16	0 - 240	68	47	53	27
600200IR	Ø 53 Indicatore rosso Red index	Attacco radiale Bottom connection	0 - 6	0 - 90	71	48	53	27
600201IR			0 - 10	0 - 150	71	48	53	27
600250IR	Ø 53 Indicatore rosso Red index	Attacco posteriore Rear connection	0 - 6	0 - 90	66	48	53	27
600251IR			0 - 10	0 - 150	66	48	53	27

M5

# MANOMETRI / PRESSURE GAUGES / Ø 63

Manometri a secco /  
Dry pressure gauges

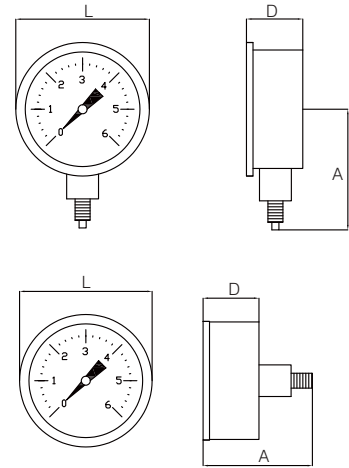

Modello / Model

Ø 63

Materiale cassa / Casing material

ABS

Attacco / Connection

Ottone / Brass

## Caratteristiche tecniche / Construction features

- **Manometri a molla di Bourdon /**  
Bourdon spring pressure gauges
- **Misura / Size**  
Ø 63

## Componenti e materiali / Components and materials

<b>Cassa /</b> Casing	ABS nero / black
<b>Meccanismo /</b> Mechanism	Ottone / Brass
<b>Attacco /</b> Connection	Ottone (1/4" M gas) / Brass (1/4" M gas)
<b>Vetro /</b> Glass	Acrilico / Acrylic

## Dimensioni e pesi / Dimensions and weights

Codice Code	Versione Type	Caratteristiche Features	Scala Scale		Peso in gr. Weight in gr.	Dimensioni in mm Dimensions in mm		
			bar	psi		A	L	D
600260	Ø 63	Attacco radiale	0 - 6	0 - 90	75	56	63	30
600261	Indicatore rosso	Bottom connection	0 - 10	0 - 150	75	56	63	30
600262	Red index		0 - 16	0 - 240	75	56	63	30
600272	Ø 63	Attacco posteriore	0 - 6	0 - 90	84	49	63	29
600273	Indicatore rosso	Rear connection	0 - 10	0 - 150	84	49	63	29
600274	Red index		0 - 16	0 - 240	84	49	63	29

M5

# MANOMETRI / PRESSURE GAUGES / Ø 63

Manometri in bagno di glicerina /  
Glycerin - filled pressure gauges

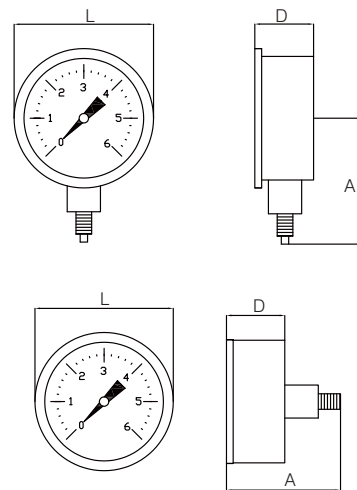

Modello / Model

Ø 63

Materiale cassa / Casing material

Aisi 304

Attacco / Connection

Ottone / Brass / Aisi 304

## Caratteristiche tecniche / Construction features

- **Manometri in bagno di glicerina tipo a molla di Bourdon** / Glycerin - filled pressure gauges - Bourdon spring type
- **Misura** / Size  
Ø 63

## Componenti e materiali / Components and materials

<b>Cassa</b> / Casing	Acciaio inox / SS Aisi 304
<b>Meccanismo</b> / Mechanism	Ottone / Brass Tipo / Type X Aisi 304
<b>Attacco</b> / Connection	Ottone (1/4" M gas) / Brass (1/4" M gas) Tipo / Type X Aisi 304
<b>Vetro</b> / Glass	Acrilico / Acrylic

## Dimensioni e pesi / Dimensions and weights

Codice Code	Materiale Material	Caratteristiche Features	Scala Scale		Peso in gr. Weight in gr.	Dimensioni in mm Dimensions in mm		
			bar	psi		A	L	D
600302	Ottone / Brass	Attacco radiale Bottom connection	0 - 6	0 - 90	180	55	63	30
600300			0 - 10	0 - 150	180	55	63	30
600303			0 - 16	0 - 240	180	55	63	30
600302P	Aisi 304	Attacco posteriore Rear connection	0 - 6	0 - 90	184	55	63	27
600300P			0 - 10	0 - 150	184	55	63	27
600303P			0 - 16	0 - 240	184	55	63	27
600302X	Aisi 304	Attacco radiale Bottom connection	0 - 6	0 - 90	207	56	63	30
600300X			0 - 10	0 - 150	207	56	63	30
600303X			0 - 16	0 - 240	207	56	63	30

M5

# MANOMETRI / PRESSURE GAUGES / Ø 100

Manometri in bagno di glicerina /  
Glycerin - filled pressure gauges

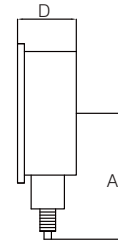
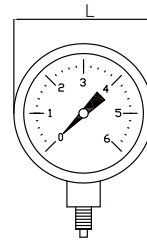

Modello / Model

Ø 100

Materiale cassa / Casing material

Aisi 304

Attacco / Connection

Aisi 304

## Caratteristiche tecniche / Construction features

- **Manometri in bagno di glicerina tipo a molla di Bourdon** / Glycerin - filled pressure gauges - Bourdon spring type
- **Misura** / Size  
Ø 100
- **Scale disponibili** / Available scales  
0-16 / 25 / 100 bar

## Dimensioni e pesi / Dimensions and weights

Codice Code	Caratteristiche Features	Scala Scale		Peso in gr. Weight in gr.	Dimensioni in mm Dimensions in mm		
		bar	psi		A	L	D
600400	Attacco radiale	0 - 16	0 - 240	561	85	100	36
600401	Bottom connection	0 - 25	0 - 400	561	85	100	36
600404		0 - 100	0 - 1500	561	85	100	36

## Componenti e materiali / Components and materials

<b>Cassa</b> / Casing	Acciaio inox / SS Aisi 304
<b>Meccanismo</b> / Mechanism	Acciaio inox / SS Aisi 304
<b>Attacco</b> / Connection	Acciaio inox Aisi 304 (1/2" M gas) / SS Aisi 304 (1/2" M gas)
<b>Vetro</b> / Glass	Polycarbonato / Polycarbonate

M5

# FLOYPRES / ST

**Pressoflussostato /**  
Pressure-flow-switch

**Apparecchio per il**  
**controllo e la protezione**  
**della pompa /**

Electronic device for control  
and protection of the pump

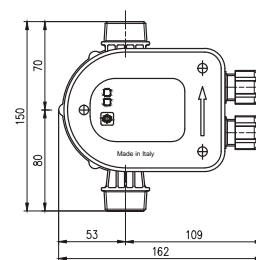
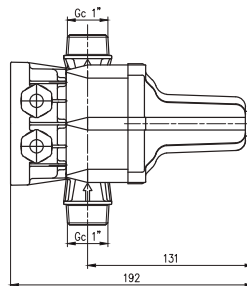

**Modello / Model**  
**FLOYPRES ST**

**Tensione / Voltage**  
1 x 230 Vac

**Potenza / Power**  
max 1,1 kW (1,5 Hp)

**Corrente / Current**  
max 8 A

**Pressione / Starting pressure**  
1,5 bar

## Caratteristiche tecniche /

### Construction features

- **Tensione di linea monofase /**  
Single-phase mains voltage  
230 Vac
- **Variazioni di tensione accettabili /**  
Acceptable voltage fluctuation  
+/- 10%
- **Frequenza / Frequency**  
50 / 60 Hz
- **Corrente / Current**  
max 8 A
- **Potenza / Power**  
max 1,1 kW (1,5 HP)
- **Indice di protezione /**  
Protection degree  
IP 65
- **Pressione di esercizio /**  
Operating pressure  
max 10 bar
- **Temperatura di esercizio /**  
Working temperature  
max 60 °C
- **Flusso minimo / Minimum flow**  
~ 1 l/min
- **Attacco filettato / Threaded end**  
Gc 1"
- **Certificazioni / Certifications**  
TÜV SÜD

## Punti di forza /

### Strengths

- **Avvia ed arresta la pompa in funzione dell'apertura o chiusura degli utilizzi. /**  
Starts and stops the pump depending on opening and closing of the taps.
- **Arresta la pompa in caso di mancanza d'acqua e la protegge dalla marcia a secco. /**  
Stops the pump in case of a water shortage and protects it from dry running.
- **Può essere montato su pompe di superficie e su pompe sommerse. /**  
Can be installed on surface and submersible pumps.
- **Non necessita di vaso d'espansione, valvola di ritegno, filtro e raccordi. /**  
No need for an expansion tank, check valve, filter or fittings.
- **Non necessita di manutenzione. /**  
Maintenance free.

## Perdite di carico /

### Friction losses diagrams

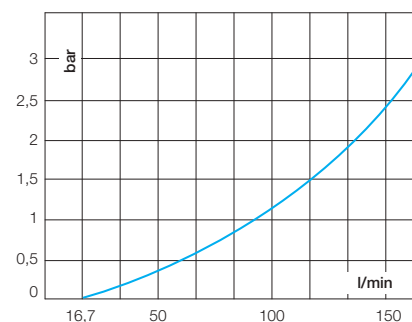

**Disponibile /**  
**Available**



**Raccordo / Coupling**  
**6ST7220101 1" MF**



## Dimensioni e pesi /

### Dimensions and weights

Codice Code	Attacco Connection	Tensione Voltage	Potenza massima Max. power
600900	1" M	230 Vac	1,1 kW (1,5 Hp)

M5

# FLOYPRES

**Pressoflussostato /**  
Pressure-flow-switch

**Apparecchio per il controllo e la protezione della pompa /**

Electronic device for control and protection of the pump

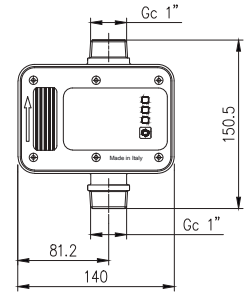
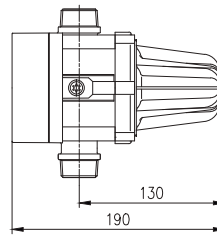

<b>Modello / Model</b> <b>FLOYPRES</b>	<b>Tensione / Voltage</b> 1 x 115/230 Vac	<b>Potenza / Power</b> max 1,5 kW (2 Hp)	<b>Corrente / Current</b> max 10 A	<b>Pressione / Starting pressure</b> 1,5 bar
---	--	---	---------------------------------------	---

## Caratteristiche tecniche / Construction features

- **Tensione di linea monofase /** Single-phase mains voltage 115 / 230 Vac
- **Variazioni di tensione accettabili /** Acceptable voltage fluctuation +/- 10%
- **Frequenza / Frequency** 50 / 60 Hz
- **Corrente / Current** max 10 A
- **Potenza / Power** max 0,75 kW (1 HP) a 115 V, 1,5 kW (2 HP) a 230 V
- **Indice di protezione /** Protection degree IP 65
- **Pressione di esercizio /** Operating pressure max 12 bar
- **Temperatura di esercizio /** Working temperature max 65 °C
- **Flusso minimo /** Minimum flow ~ 1 l/min
- **Attacco filettato /** Threaded end Gc 1"
- **Certificazioni /** Certifications TÜV SÜD

## Dimensioni e pesi / Dimensions and weights

Codice Code	Attacco Connection	Tensione Voltage	Potenza massima Max. power
600910	1" M	230 Vac	1,5 kW (2 Hp)
		115 Vac	0,75 kW (1 Hp)

## Punti di forza / Strengths

- **Può essere alimentato sia a 115 Vac che a 230 Vac.** / It can be energized at either 115 Vac or 230 Vac.
- **Avvia ed arresta la pompa in funzione dell'apertura o chiusura degli utilizzi.** / Starts and stops the pump depending on opening and closing of the taps.
- **Arresta la pompa in caso di mancanza d'acqua e la protegge dalla marcia a secco.** / Stops the pump in case of a water shortage and protects it from dry running.
- **È dotato di riarmi automatici in caso di blocco e di funzione antibloccaggio.** / Is equipped with automatic restart in case of failure and anti-jamming function.
- **Può essere montato su pompe di superficie e su pompe sommerse.** / Can be installed on surface and submersible pumps.
- **Non necessita di vaso d'espansione, valvola di ritegno, filtro e raccordi.** / No need for an expansion tank, check valve, filter or fittings.
- **Non necessita di manutenzione.** / Maintenance free.

## Perdite di carico / Friction losses diagrams

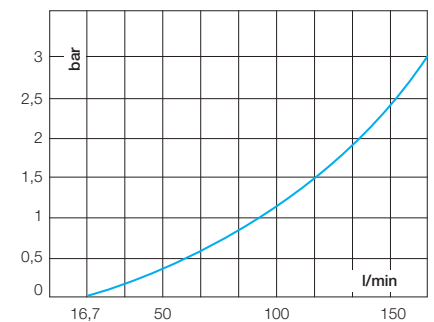

## Su richiesta / On request

**Versione con pressione di ripartenza**  
Restart value type  
1,2 / 2,2 / 3 bar

## Disponibile / Available

**Raccordo / Coupling**  
6ST7220101 1" MF



M5

# FLOYPRES / RM

**Pressoflussostato /**  
Pressure-flow-switch

**Apparecchio per il controllo e la protezione della pompa /**

Electronic device for control and protection of the pump

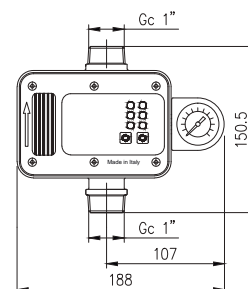
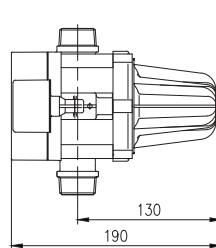

**Modello / Model**  
**FLOYPRES RM**

**Tensione / Voltage**  
1 x 115/230 Vac

**Potenza / Power**  
max 1,5 kW (2 Hp)

**Corrente / Current**  
max 10 A

**Pressione / Starting pressure**  
1,5-2-2,5 bar

## Caratteristiche tecniche / Construction features

- **Tensione di linea monofase /** Single-phase mains voltage 115 / 230 Vac
- **Variazioni di tensione accettabili /** Acceptable voltage fluctuation +/- 10%
- **Frequenza / Frequency** 50 / 60 Hz
- **Corrente / Current** max 10 A
- **Potenza / Power** max 0,75 kW (1 HP) a 115 V, 1,5 kW (2 HP) a 230 V
- **Indice di protezione /** Protection degree IP 65
- **Pressione di esercizio /** Operating pressure max 12 bar
- **Temperatura di esercizio /** Working temperature max 65 °C
- **Flusso minimo / Minimum flow** ~ 1 l/min
- **Attacco filettato / Threaded end** Gc 1"
- **Certificazioni / Certifications** TÜV SÜD

## Punti di forza / Strengths

- **Consente di impostare la pressione di ripartenza della pompa. /** It allows to set the restart pressure value of the pump.
- **Può essere alimentato sia a 115 Vac che a 230 Vac. /** It can be energized at either 115 Vac or 230 Vac.
- **Avvia ed arresta la pompa in funzione dell'apertura o chiusura degli utilizzi. /** Starts and stops the pump depending on opening and closing of the taps.
- **Arresta la pompa in caso di mancanza d'acqua e la protegge dalla marcia a secco. /** Stops the pump in case of a water shortage and protects it from dry running.
- **È dotato di riarmi automatici in caso di blocco e di funzione antibloccaggio. /** Is equipped with automatic restart in case of failure and anti-jamming function.
- **Può essere montato su pompe di superficie e su pompe sommerse. /** Can be installed on surface and submersible pumps.
- **Non necessita di vaso d'espansione, valvola di ritegno, filtro e raccordi. /** No need for an expansion tank, check valve, filter or fittings.
- **Non necessita di manutenzione. /** Maintenance free.

## Perdite di carico / Friction losses diagrams

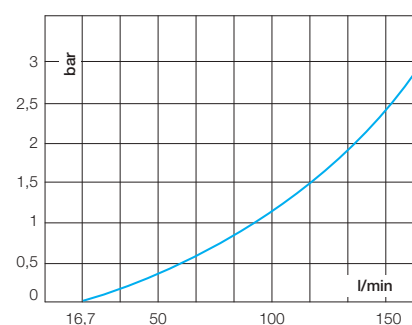

**Disponibile / Available**



**Raccordo / Coupling**  
**6ST7220101 1" MF**



## Dimensioni e pesi / Dimensions and weights

Codice Code	Attacco Connection	Tensione Voltage	Potenza massima Max. power
600920	1" M	230 Vac	1,5 kW (2 Hp)
		115 Vac	0,75 kW (1 Hp)



M5

# FLOYPRES / XL

**Pressoflussostato /**  
Pressure-flow-switch

**Apparecchio per il controllo e la protezione della pompa /**

Electronic device for control and protection of the pump

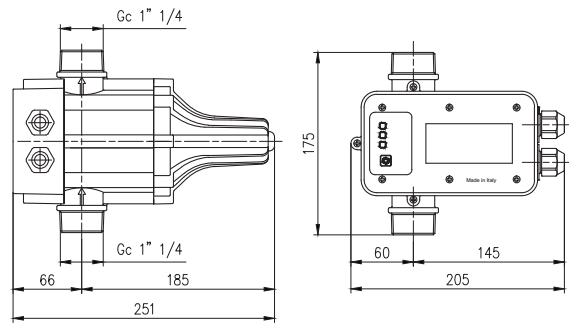

<b>Modello / Model</b> <b>FLOYPRES XL</b>	<b>Tensione / Voltage</b> 1 x 115/230 Vac	<b>Potenza / Power</b> max 2,2 kW (3 Hp)	<b>Corrente / Current</b> max 16 A	<b>Pressione / Starting pressure</b> 1,5 bar
--	--	---	---------------------------------------	---

## Caratteristiche tecniche / Construction features

- **Tensione di linea monofase /** Single-phase mains voltage 115 / 230 Vac
- **Variazioni di tensione accettabili /** Acceptable voltage fluctuation +/- 10%
- **Frequenza / Frequency** 50 / 60 Hz
- **Corrente / Current** max 16 A
- **Potenza / Power** max 1,1kW (1,5 HP) a 115 V 2,2kW (3 HP) a 230 V
- **Indice di protezione / Protection degree** IP 65
- **Pressione di esercizio /** Operating pressure max 12 bar
- **Temperatura di esercizio /** Working temperature max 60°C
- **Flusso minimo / Minimum flow** ~ 1 l/min
- **Attacco filettato / Threaded end** Gc 1"1/4
- **Certificazioni / Certifications** TÜV SÜD

## Punti di forza / Strengths

- **Può essere alimentato sia a 115 Vac che a 230 Vac.** / Can be energized with either 115 Vac or 230 Vac.
- **Avvia ed arresta la pompa in funzione dell'apertura o chiusura degli utilizzatori.** / Starts and stops the pump depending on opening and closing of the taps.
- **È dotato di attacchi maschio 1"1/4 per garantire maggiore portata.** / It has 1"1/4 male connections to guarantee a higher flow rate.
- **Arresta la pompa in caso di mancanza d'acqua e la protegge dalla marcia a secco.** / Stops the pump in case of a water shortage and protects it from dry running.
- **È dotato di riarmi automatici in caso di blocco e di funzione antibloccaggio.** / Is equipped with automatic restarts in case of failure and anti-jamming function.
- **Non necessita di vaso d'espansione, valvola di ritegno, filtro e raccordi.** / No need for an expansion tank, check valve, filter or fittings.
- **Può essere montato su pompe di superficie e su pompe sommerse fino a 3 HP. Non necessita di manutenzione.** / Can be installed on surface and submersible pumps up to 3 HP.

## Perdite di carico / Friction losses diagrams

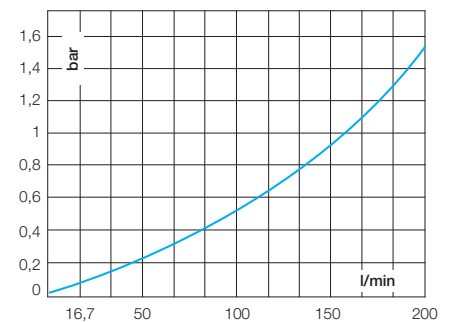

## Su richiesta / On request

**Versione con pressione di ripartenza**  
Restart value type  
1,2 / 2,2 / 3 / 4 bar

## Dimensioni e pesi / Dimensions and weights

Codice Code	Attacco Connection	Tensione Voltage	Potenza massima Max. power
600930	1"1/4 M	230 Vac	2,2 kW (3 Hp)
		115 Vac	1,1 kW (1,5 Hp)

M5

# FLOYPRES / XL 3PHU

**Pressoflussostato /**  
Pressure-flow-switch

**Apparecchio per il  
controllo e la protezione  
della pompa trifase /**  
Electronic device for control  
and protection of the three-  
phase pump

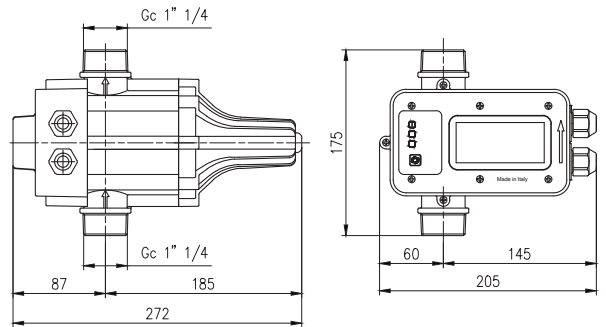

Modello / Model

**FLOYPRES XL 3PHU**Tensione / Voltage  
3 x 230/400 VacPotenza / Power  
max 2,2 kW (3hp)Corrente / Current  
max 6 APressione / Starting pressure  
1,5 bar

## Caratteristiche tecniche / Construction features

- **Tensione di linea trifase /**  
Three-phase mains voltage  
230 Vac / 400 Vac
- **Tensione motore pompa trifase /**  
Three-phase pump motor voltage  
230 V Δ o 400 V Y
- **Variazioni di tensione accettabili /**  
Acceptable voltage fluctuation  
+/- 10%
- **Frequenza / Frequency**  
50 / 60 Hz
- **Corrente / Current**  
max 6 A
- **Potenza / Power**  
max 1,1 kW (1,5 HP) a 230 V  
2,2 kW (3 HP) a 400 V
- **Indice di protezione /**  
Protection degree  
IP 65
- **Pressione di esercizio /**  
Operating pressure  
max 12 bar
- **Temperatura di esercizio /**  
Working temperature  
max 50 °C
- **Flusso minimo / Minimum flow**  
~ 1 l/min
- **Attacco filettato / Threaded end**  
Gc 1"1/4
- **Certificazioni / Certifications**  
TÜV SÜD

## Punti di forza / Strengths

- **Può essere alimentato sia trifase 230 Vac che trifase 400 Vac.** / It can be supplied either three-phase 230 Vac or three-phase 400 Vac.
- **Protezione contro l'inversione accidentale del senso di rotazione della pompa.** / Reverse rotation protection.
- **Protezione del motore in caso di mancanza di una fase in alimentazione.** / Motor protection in case of phase failure during power supply.
- **Avvia ed arresta la pompa in funzione dell'apertura o chiusura degli utilizzi.** / Starts and stops the pump depending on opening and closing of the taps.
- **È dotato di attacchi maschio 1"1/4 per garantire maggiore portata.** / It has 1"1/4 male connections to guarantee a higher flow rate.
- **Arresta la pompa in caso di mancanza d'acqua e la protegge dalla marcia a secco.** / Stops the pump in case of a water shortage and protects it from dry running.
- **È dotato di riarmi automatici in caso di blocco e di funzione antibloccaggio.** / Is equipped with automatic restart in case of failure and anti-jamming function.
- **Non necessita di vaso d'espansione, valvola di ritegno, filtro e raccordi.** / No need for an expansion tank, check valve, filter or fittings.
- **Può essere montato su pompe di superficie e su pompe sommerse fino a 3 HP.** / Can be installed on surface and submersible pumps up to 3 HP.
- **Non necessita di manutenzione.** / Maintenance free.

## Perdite di carico / Friction losses diagrams

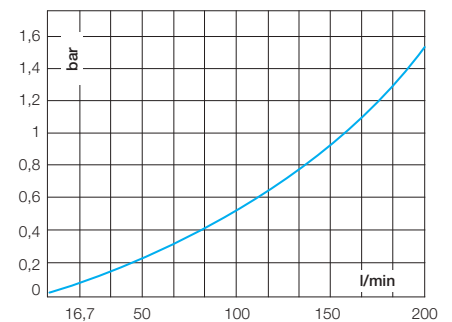

## Su richiesta / On request

**Versione con pressione  
di ripartenza**  
Restart value type  
1,2 / 2,2 / 3 / 4 bar

## Dimensioni e pesi / Dimensions and weights

Codice Code	Attacco Connection	Tensione Voltage	Potenza massima Max. power
600940	1" 1/4 M	400 Vac	2,2 kW (3 Hp)
		230 Vac	1,1 kW (1,5 Hp)

M5

# PRESSOSTATI / PRESSURE SWITCHES

**A membrana** / A membrana

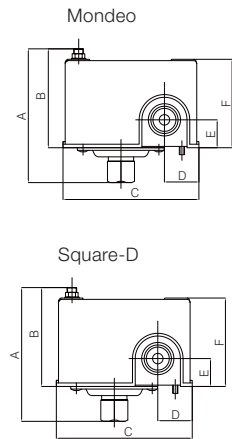

**Modello** / Model

**MONDEO / SQUARE D**

**Tensione nominale** / Nominal tension

230 V 50 Hz

**Pressione** / Pressure

1-10 bar

## Caratteristiche tecniche / Construction features

- **Impiego: controllo della pressione in elettropompe e nei compressori** / Application: control of pressure in water pumps and air compressors
- **Attacco filettato** / Threaded connection G 1/4" F
- **Tensione nominale** / Nominal tension 230 V 50 Hz
- **Assorbimento massimo** / Maximum consumption 8 A
- **Regolazione** / Regulation 0 – 4 / 7/ 10 bar
- **Frequenza di cicli** / Frequency of cycles 60 cicli al minuto / cycles/min
- **Differenziale** / Differential variabile / variable

## Dimensioni e pesi / Dimensions and weights

Codice Code	Versione Type	Caratteristiche Features	Campo di regolazione Regulating scale	Peso in gr. Weight in gr.	Dimensioni in mm Dimensions in mm					
					A	B	C	D	E	F
600100	MONDEO	MONDEO 4 bar	1,4 – 4,6 bar	356	95	70	97,5	24,5	20	63,5
600101		MONDEO 7 bar	3,0 – 7,0 bar	356	95	70	97,5	24,5	20	63,5
600102		MONDEO 10 bar	6,0 – 10,5 bar	356	95	70	97,5	24,5	20	63,5
600100SD	SQUARE-D	FSG - 2	1,4 – 4,6 bar	340	96	73	102	31	22	63,5
600102SD		FYG - 22	2,8 – 7,0 bar	340	94	73	102	31	22	63,5
600101SD		FYG - 32	5,6 – 10,5 bar	340	94	73	102	31	22	63,5

M5

# TRASDUTTORI DI PRESSIONE

Pressure Transducers



**Modello / Model**

**RCIV**

**Materiale / Material**

Aisi 304 - Aisi 316

**Pressione / Pressure**

0 – 25 bar

## Caratteristiche tecniche / Construction features

- **Impiego: rilevamento e trasmissione della pressione in circuiti idraulici** / Application: pressure detection and transmission in hydraulic circuits
- **Connessione idraulica** / Hydraulic connection  
G 1/4" M
- **Protezione** / Protection  
IP 55
- **Uscita** / Output  
4 – 20 mA
- **Temperatura massima del fluido** / Max fluid temp.  
45°C

## Dimensioni e pesi / Dimensions and weights

Codice Code	Versione Type	Caratteristiche Features	Taratura Set up	Peso in gr. Weight in gr.
6RCIV00221	AISI 304	Cavo / Cable 1,5 m	0 – 10 bar	103
6RCIV00203		Cavo / Cable 1,5 m	0 – 16 bar	103
6RCIV00222		Cavo / Cable 1,5 m	0 – 25 bar	103
6RCIV00223	AISI 316	Cavo / Cable 1,5 m	0 – 10 bar	103
6RCIV00224		Cavo / Cable 1,5 m	0 – 16 bar	103
6RCIV00225		Cavo / Cable 1,5 m	0 – 25 bar	103

M6

# QUICK STOP

**Regolatori idraulici di livello tipo quick stop** / Hydraulic level regulators quick stop type



**Modello / Model**  
**QUICK STOP**

**Materiale / Material**  
Policarbonato / Polycarbonate

**Pressione di lavoro / Working pressure**  
0,2 – 6 bar

## Caratteristiche tecniche / Construction features

- **Temperatura di funzionamento** / Operating Temperature  
0 – +50°C
- **Temperatura di immagazzinamento** / Storage temperature  
-20°C – +80°C
- **Servizio** / Service  
continuo / continuous
- **Pressione di lavoro** / Working pressure  
0,2 – 6 bar
- **Pressione massima** / Maximum pressure  
10 bar
- **Equipaggiato con filtro d'ingresso** / Equipped with inlet filter
- **Massima rapidità d'intervento del sistema**  
Maximum rapidity of operation of the system

## Dimensioni e pesi / Dimensions and weights

<b>Codice</b> Code	<b>Attacco</b> Connection	<b>Ø uscita in mm</b> Exit Ø in mm	<b>Peso in gr.</b> Weight in gr.	<b>Dimensioni in mm</b> Dimensions in mm
603901	1/2"	25	350	240x80x50
603902	3/4"	25	350	350x150x70
603903	1"	25	350	350x150x70
603904	1" 1/4	25	350	350x150x70
603905	1" 1/2	25	350	350x150x70

M6

Modello / Model  
**NICK / LEON**

Materiale / Material  
Resina / Resin

PN  
8



### Caratteristiche tecniche / Construction features

- **Alimentatori automatici d'aria per impianti con pompa centrifuga** / Automatic air feeders for water booster systems with centrifugal pump
- **Resina sintetica ad alta resistenza** / High resistance synthetic resin
- **Pressione nominale di esercizio** / Nominal working pressure 800 Kpa (8 bar)
- **Connessioni filettate gas secondo** / Threaded ends gas according to Ø 1/2" x 1/2"
- **Applicazioni su impianti con autoclave di piccola o media capacità (modello NICK) e di media o grande capacità (modello LEON) come da tabella** / Use for plants with small or medium (NICK model) and medium or big pressure tanks (see the table)

### Dimensioni e pesi / Dimensions and weights

Codice Code	Modello Model	Capacità autoclave in lt Tank capacity in lt	Connessioni filettate Threaded connections		Dimensioni in mm Dimensions in mm	
			Ø1	Ø2	D	H
6NICK	NICK	Fino a 750 lt Until 750 lt	1/2" M	1/2" M	112	220
6LEON	LEON	Da / from 1000 lt a / to 2000 lt	1/2" M	1/2" M	112	320

M6

Modello / Model  
**AIR CONTROL**

Materiale / Material  
PA66 + 30% FV/GF – Ottone / Brass

PN  
10

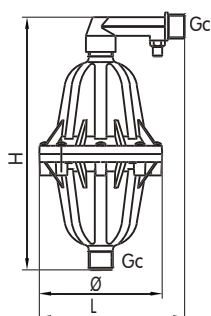

### Caratteristiche tecniche / Construction features

- **Alimentatori automatici d'aria per impianti con pompa centrifuga** / Automatic air feeders for water booster systems with centrifugal pump
- **Applicazioni su impianti con autoclave di capacità come da tabella** / Use for plants with capacity according the table
- **Corpo** / Body  
Nylon 66 stabilizzato con fibra di vetro al 30% / Stabilized nylon 66 with 30% glass fiber
- **Raccordo serbatoio** / Tank coupling  
Ottone / Brass
- **Pressione massima di esercizio** / Max working pressure 10 bar

### Dimensioni e pesi / Dimensions and weights

Codice Code	Modello Model	Capacità autoclave in lt Tank capacity in lt	Dimensioni in mm Dimensions in mm			
			H	L	Ø	Gc
6PFAL01	500	100/500	220	126	106	1/2"
6PFAL02	2000	750/2000	275	185	162	3/4"
6PFAL03	4000	2500/4000	405	185	162	3/4"
6PFAL04	6000	4000/6000	535	185	162	3/4"

M6

# TUBI FLESSIBILI / FLEXIBLE HOSES

Antivibranti / Anti-vibrating



<b>Modello / Model</b> TF	<b>Materiale / Material</b> Aisi 304	<b>Tubo interno / Internal pipe</b> EPDM	<b>DN</b> 8 – 50	<b>PN</b> 10
------------------------------	---	---	---------------------	-----------------

## Caratteristiche tecniche / Construction features

- **Pressione nominale di esercizio / Nominal working pressure**  
10 bar
- **Temperatura massima di esercizio / Maximum working temperature**  
110°C
- **Applicazioni: impianti idraulici, autoclavi, contatori d'acqua / Use: hydraulic systems, autoclaves, water meters**

## Componenti e materiali / Components and materials

<b>Materiale interno / Internal material</b>	Gomma EPDM omologata / Certified EPDM rubber
<b>Treccia esterna / Braiding</b>	Acciaio inox / SS Aisi 304L
<b>Raccordi / Couplers</b>	Maschio-femmina in ottone nichelato / Male-female in nickel plated brass

## Dimensioni e pesi / Dimensions and weights

<b>Codice</b> Code	<b>Misura</b> Size	<b>Lunghezze disponibili in mm</b> Available lengths in mm
TF0001	1/4" - 1/2"	700
TF0002		1000
TF0010	1/2" - 1/2"	600
TF0011		1000
TF0020	3/4" - 3/4"	600
TF0021		1000
TF0030	1" - 1"	600
TF0031		1000
TF0040	1" 1/4 - 1" 1/4	600
TF0041		1000
TF0050	1" 1/2 - 1" 1/2	600
TF0051		1000
TF0060	2" - 2"	600
TF0061		1000

M6

## BARILOTTI / EXTENSION SCREWS

**Con gancio per pompe sommerse** / With hook for submersible pumps

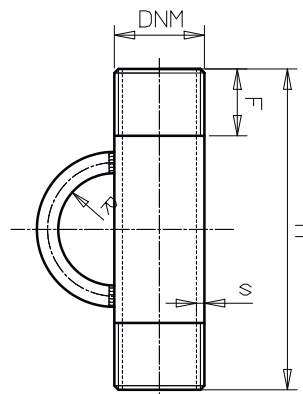

Modello / Model

**CON GANCIO / WITH HOOK**

Materiale / Material

Aisi 304

DN

25 – 80

PN

25

### Caratteristiche tecniche / Construction features

- **Connessioni filettate gas maschio secondo** / Threaded ends gas male according to UNI EN ISO 228/1
- **Gancio saldato a TIG** / Hook welded with TIG method
- **Ideali per pompe sommerse** / Suitable for submersible pumps

### Componenti e materiali / Components and materials

**Materiale /** Acciaio inox /  
**Material** SS Aisi 304

**Su richiesta /**  
**On request**

**Con 2 ganci /** With 2 hooks

### Dimensioni e pesi / Dimensions and weights

Codice Code	DNM	Peso in gr. Weight in gr.	Dimensioni in mm Dimensions in mm			
			H	R	F	s
999999918	1" M	245	120	21	25	3
999999908	1" 1/4 M	380	150	21	25	3
999999919	1" 1/2 M	435	150	21	25	3
999999909	2" M	700	200	30	25	3
999999906	2"1/2 M	1.250	250	30	25	4
999999907	3" M	1.810	250	30	30	4



M6

# STAFFA / BRACKET

**Per installazione sulla testa di pozzi** / Suitable for installation on the surface part of a well

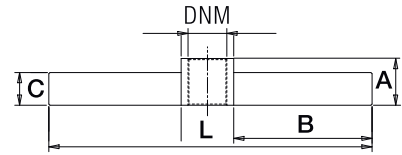

Modello / Model

**STAFFA / BRACKET**

Materiale / Material

Aisi 304

DN

25 – 50

PN

25

## Caratteristiche tecniche / Construction features

- **Applicazione: staffa di sostegno per pompe sommerse da pozzo** / Application support bracket for submersible pumps for wells
- **Connessioni filettate gas femmina secondo** / Threaded ends gas female according to UNI EN ISO 228/1

## Dimensioni e pesi / Dimensions and weights

Codice Code	DNM	Peso in gr. Weight in gr.	Dimensioni in mm Dimensions in mm			
			L	A	B	C
5MO250	1" F	595	357	40	156	28
5MO251	1"1/4 F	545	362	40	156	28
5MO252	1"1/2 F	745	372	45	156	28
5MO253	2" F	810	382	50	156	28

M6

# RACCORDI / CONNECTIONS

5 vie / 5 ways

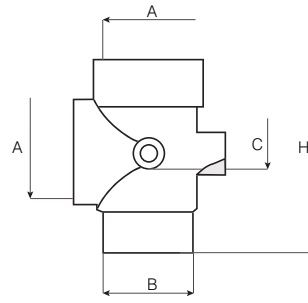

**Modello / Model**  
**5 VIE / 5 WAYS**

**Materiale / Material**  
Aisi 316 – Ottone/Brass

**Lunghezza / Length**  
72-97 mm

## Caratteristiche tecniche / Construction features

- **Raccordi a 5 vie per accoppiamento pompe** / 5 ways fittings for pumps
- **Connessioni filettate secondo** / Threaded ends according to UNI ISO 228/1
- **Pressione nominale di esercizio** / Nominal working pressure 10 bar
- **Massima temperatura di esercizio** / Maximum working pressure 180° C

## Dimensioni e pesi / Dimensions and weights

Codice Code	Materiale Material	Peso in gr. Weight in gr.	Dimensioni in mm Dimensions in mm			
			A	B	C	H
5MO200	Acciaio inox / SS Aisi 316	280	1" F	1" M	1/4" F	97
5MO201	Ottone corto / Small brass	215	1" F	1" M	1/4" F	72
5MO202	Ottone lungo / Long brass	220	1" F	1" M	1/4" F	90



## Raccorderia

### Pipe fittings

- **Si tratta di raccordi idraulici filettati in acciaio inox Aisi 304 e 316 indicati per impianti di trasporto d'acqua, aria compressa, olio e vapore. Sono adatti in impianti domestici e industriali.** / These are threaded hydraulic fittings made of Aisi 304 and 316 stainless steel, and they are suitable for transferring water, compressed air, oil and vapour. They can be used with domestic and industrial systems.
- **Accanto alla gamma tradizionale, sono disponibili raccordi personalizzati grazie a lavorazioni che permettono di modificare il prodotto secondo le specifiche del cliente.** / Personalised fittings are also available alongside the traditional range, thanks to processing that modifies the product according to client specifications.
- **La gamma è disponibile da 1/4" fino a 4", a seconda delle tipologie.** / The available range goes from 1/4" to 4" according to type.

M7

Modello / Model

**GOMITO 90° FF / 90° FF ELBOW**

Materiale / Material

Aisi 316



### Caratteristiche tecniche / Construction features

- **Raccorderia filettata microfusa** / Microcasted threaded fittings
- **Connessioni filettate secondo** / Threaded ends according to ISO 10226-1
- **Temperatura di funzionamento** / Working temperature -20°C – +180°C
- **Pressione massima** / Max. working pressure 20 bar fino a / up to 40°C
- **Tolleranze** / Tolerances ISO 4144

Su richiesta /  
On request

Filettatura NPT / NPT thread

### Dimensioni e pesi / Dimensions and weights

Codice Code	Misura R Size R	Dimensioni in mm Dimensions in mm	
		A	
902000	1/4"	19	
902001	3/8"	23	
902002	1/2"	27	
902003	3/4"	32	
902004	1"	38	
902005	1" 1/4	45	
902006	1" 1/2	48	
902007	2"	57	
902008	2" 1/2	69	
902009	3"	78	
902010	4"	96	

M7

Modello / Model

**GOMITO 90° MF / 90° MF ELBOW**

Materiale / Material

Aisi 316



### Caratteristiche tecniche / Construction features

- **Raccorderia filettata microfusa** / Microcasted threaded fittings
- **Connessioni filettate secondo** / Threaded ends according to ISO 10226-1
- **Temperatura di funzionamento** / Working temperature -20°C – +180°C
- **Pressione massima** / Max. working pressure 20 bar fino a / up to 40°C
- **Tolleranze** / Tolerances ISO 4144

Su richiesta /  
On request

Filettatura NPT / NPT thread

### Dimensioni e pesi / Dimensions and weights

Codice Code	Misura R Size R	Dimensioni in mm Dimensions in mm	
		A	B
902020	1/4"	19	27
902021	3/8"	23	29
902022	1/2"	27	35
902023	3/4"	32	40
902024	1"	38	46
902025	1" 1/4	45	54
902026	1" 1/2	48	57
902027	2"	57	70
902028	2" 1/2	69	83
902029	3"	78	94
902030	4"	96	115

M7

Modello / Model

**CROCE FEMMINA / FEMALE CROSS**

Materiale / Material

Aisi 316

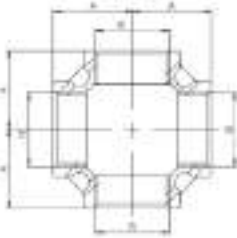
**Caratteristiche tecniche /**  
Construction features

- **Raccorderia filettata microfusa** / Microcasted threaded fittings
- **Conessioni filettate secondo** / Threaded ends according to ISO 10226-1
- **Temperatura di funzionamento** / Working temperature -20°C – +180°C
- **Pressione massima** / Max. working pressure 20 bar fino a / up to 40°C
- **Tolleranze** / Tolerances ISO 4144

**Su richiesta /**  
On request

Filettatura NPT / NPT thread

**Dimensioni e pesi /**  
Dimensions and weights

Codice Code	Misura R Size R	Dimensioni in mm Dimensions in mm
		A
903130	1/4"	19
903131	3/8"	23
903132	1/2"	27
903133	3/4"	32
903134	1"	38
903135	1" 1/4	45
903136	1" 1/2	48
903137	2"	57

M7

Modello / Model

**TEE FEMMINA / EQUAL TEE**

Materiale / Material

Aisi 316

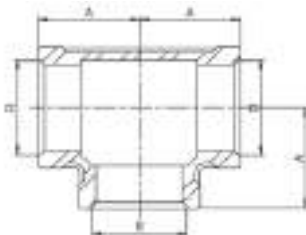
**Caratteristiche tecniche /**  
Construction features

- **Raccorderia filettata microfusa** / Microcasted threaded fittings
- **Conessioni filettate secondo** / Threaded ends according to ISO 10226-1
- **Temperatura di funzionamento** / Working temperature -20°C – +180°C
- **Pressione massima** / Max. working pressure 20 bar fino a / up to 40°C
- **Tolleranze** / Tolerances ISO 4144

**Su richiesta /**  
On request

Filettatura NPT / NPT thread

**Dimensioni e pesi /**  
Dimensions and weights

Codice Code	Misura R Size R	Dimensioni in mm Dimensions in mm
		A
902040	1/4"	19
902041	3/8"	23
902042	1/2"	27
902043	3/4"	32
902044	1"	38
902045	1" 1/4	45
902046	1" 1/2	48
902047	2"	57
902048	2" 1/2	69
902049	3"	78
902050	4"	96

M7

Modello / Model

**PORTAGOMMA MASCHIO / HEXAGONAL HOSE NIPPLE**

Materiale / Material

Aisi 316

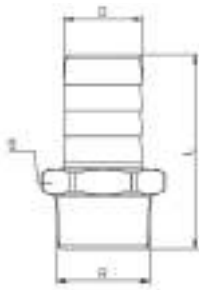

### Caratteristiche tecniche / Construction features

- **Raccorderia filettata microfusa** / Microcasted threaded fittings
- **Connessioni filettate secondo** / Threaded ends according to ISO 10226-1
- **Temperatura di funzionamento** / Working temperature -20°C – +180°C
- **Pressione massima** / Max. working pressure 20 bar fino a / up to 40°C
- **Tolleranze** / Tolerances ISO 4144

Su richiesta /  
On request



Filettatura NPT / NPT thread

### Dimensioni e pesi / Dimensions and weights

Codice Code	Misura R Size R	Dimensioni in mm Dimensions in mm		
		L	D	S
902060	1/4"	42,5	9	15
902061	3/8"	49	11,5	18
902062	1/2"	57,5	15	22
902063	3/4"	66	20	28
902064	1"	76	27	35
902065	1" 1/4	79	33	44
902066	1" 1/2	83	39,5	50
902067	2"	92	52	62
902068	2" 1/2	99	67	78
902069	3"	107,5	80	91

M7

Modello / Model

**VITE DOPPIA / HEXAGONAL NIPPLE**

Materiale / Material

Aisi 316



### Caratteristiche tecniche / Construction features

- **Raccorderia filettata microfusa** / Microcasted threaded fittings
- **Connessioni filettate secondo** / Threaded ends according to ISO 10226-1
- **Temperatura di funzionamento** / Working temperature -20°C – +180°C
- **Pressione massima** / Max. working pressure 20 bar fino a / up to 40°C
- **Tolleranze** / Tolerances ISO 4144

Su richiesta /  
On request



Filettatura NPT / NPT thread

### Dimensioni e pesi / Dimensions and weights

Codice Code	Misura R Size R	Dimensioni in mm Dimensions in mm	
		L	S
902500	1/4"	25	15
902501	3/8"	27	18
902502	1/2"	34	23
902503	3/4"	36,5	28
902504	1"	42	35
902505	1" 1/4	47,5	44
902506	1" 1/2	47,5	50
902507	2"	57	62
902508	2" 1/2	61	77
902509	3"	67,5	90

M7

Modello / Model

**VITE DOPPIA RIDOTTA / HEXAGONAL NIPPLE REDUCED**

Materiale / Material

Aisi 316



### Caratteristiche tecniche / Construction features

- **Raccorderia filettata microfusa** / Microcasted threaded fittings
- **Connessioni filettate secondo** / Threaded ends according to ISO 10226-1
- **Temperatura di funzionamento** / Working temperature -20°C – +180°C
- **Pressione massima** / Max. working pressure 20 bar fino a / up to 40°C
- **Tolleranze** / Tolerances ISO 4144

Su richiesta /  
On request

Filettatura NPT / NPT thread

### Dimensioni e pesi / Dimensions and weights

Codice Code	Misura (R1xR2) Size (R1xR2)	Dimensioni in mm Dimensions in mm	
		L	S
902150	3/8" - 1/4"	26,5	18
902151	1/2" - 1/4"	30	23
902152	1/2" - 3/8"	30,5	23
902154	3/4" - 1/2"	35,5	28
902155	1" - 1/2"	38,5	35
902156	1" - 3/4"	39,5	35
902157	1" 1/4 - 3/4"	42,5	44
902158	1" 1/4 - 1"	45	44
902159	1" 1/2 - 1"	45	50
902160	1" 1/2 - 1" 1/4	47,5	50
902161	2" - 1" 1/4	52,5	62
902162	2" - 1" 1/2	52,5	62

M7

Modello / Model

**RIDUZIONE MF / HEXAGONAL BUSHING**

Materiale / Material

Aisi 316



### Caratteristiche tecniche / Construction features

- **Raccorderia filettata microfusa** / Microcasted threaded fittings
- **Connessioni filettate secondo** / Threaded ends according to ISO 10226-1
- **Temperatura di funzionamento** / Working temperature -20°C – +180°C
- **Pressione massima** / Max. working pressure 20 bar fino a / up to 40°C
- **Tolleranze** / Tolerances ISO 4144

Su richiesta /  
On request

Filettatura NPT / NPT thread

### Dimensioni e pesi / Dimensions and weights

Codice Code	Misura (R1xR2) Size (R1xR2)	Dimensioni in mm Dimensions in mm	
		L	S
902080	3/8" - 1/4"	16	18
902081	1/2" - 1/4"	19,5	23
902082	1/2" - 3/8"	19,5	23
902083	3/4" - 3/8"	21	28
902084	3/4" - 1/2"	21	28
902085	1" - 1/2"	24	35
902086	1" - 3/4"	24	35
902087	1" 1/4 - 3/4"	27	44
902088	1" 1/4 - 1"	27	44
902089	1" 1/2 - 1"	27	50
902090	1" 1/2 - 1" 1/4	27	50
902091	2" - 1" 1/4	32	62
902092	2" - 1" 1/2	32	62
902094	2" 1/2 - 2"	34	77
902096	3" - 2" 1/2	37,5	90

M7

## KIT GIUNTO FF

**Raccordo rapido in acciaio inox per il collegamento di separatori idraulici o circolatori filettati / FF union kit. Stainless steel quick coupling for the connection of hydraulic separators or threaded circulators**

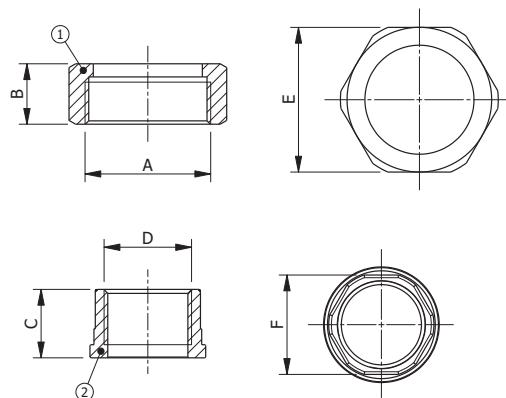

Modello / Model

KIT GIUNTO FF

Materiale / Material

Aisi 304

Tenuta / Seal

FASIT

DN

25 – 50

PN

16

### Caratteristiche tecniche / Construction features

- **Raccordi / Fittings**  
Acciaio inox Aisi 304 microfuso /  
Microcasted Aisi 304 SS  
Stainless steel
- **Guarnizione / Seal ring**  
Fasit esente amianto /  
Asbestos-free FASIT

### Componenti e materiali / Components and materials

1	<b>Ghiera /</b> Ring nut	Acciaio inox / SS Aisi 304
2	<b>Raccordo /</b> Coupling	Acciaio inox / SS Aisi 304

### Dimensioni e pesi / Dimensions and weights

Codice Code	Misura Size	DN	PN	Peso unitario in gr. Unit weight in gr.	Dimensioni ghiera in mm Dimensions ring nut in mm			Dimensioni raccordo in mm Dimensions coupling in mm		
					A	B	E	C	D	F
HPE1031-35	1" - 1"1/2	25	16	265	1" 1/2	23	55	26	1" F	38
HPE1032-36	1"1/4 - 2"	32	16	435	2"	24	68	30	1" 1/4 F	48
HPE1033-37	1"1/2 - 2"1/4	40	16	574	2" 1/4	26	74	32	1" 1/2 F	54
HPE1034-38	2" - 2"3/4	50	16	839	2" 3/4	28	90	34	2" F	66



M7

Modello / Model

**RACCORDO MF / MF COUPLING**

Materiale / Material

Aisi 316

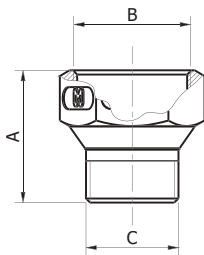

### Caratteristiche tecniche / Construction features

- **Raccorderia filettata microfusa** / Microcasted threaded fittings
- **Temperatura di funzionamento** / Working temperature  
-20°C – +180°C
- **Pressione massima** / Max. working pressure  
20 bar fino a / up to 40°C

### Dimensioni e pesi / Dimensions and weights

Codice Code	Misura Size	Peso in gr. Weight in gr.	Dimensioni in mm Dimensions in mm		
			A	B	C
902087M316	3/4" - 1"	85	44	1" G	3/4" R
902088M316	1" - 1 1/4"	140	47.5	1 1/4 G	1" R

M7

Modello / Model

**GIUNTO 3 PEZZI FF / 3 PIECES UNION FF**

Materiale / Material

Aisi 316

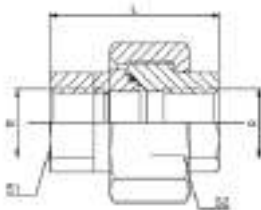

### Caratteristiche tecniche / Construction features

- **Giunto 3 pezzi FF con guarnizione in PTFE** / 3 pieces union FF with PTFE flat seat
- **Raccorderia filettata microfusa** / Microcasted threaded fittings
- **Connessioni filettate secondo** / Threaded ends according to  
ISO 10226-1
- **Temperatura di funzionamento** / Working temperature  
-20°C – +180°C
- **Pressione massima** / Max. working pressure  
20 bar fino a / up to 40°C
- **Tolleranze** / Tolerances  
ISO 4144

### Dimensioni e pesi / Dimensions and weights

Codice Code	Misura R Size R	Dimensioni in mm Dimensions in mm		
		L	S1	S2
902200	1/4"	33,5	17	29
902201	3/8"	36,5	20	34
902202	1/2"	39,5	25	39
902203	3/4"	42,5	30	47
902204	1"	50	38	58
902205	1" 1/4"	54	47	67
902206	1" 1/2"	58	53	76
902207	2"	65	66	90
902208	2" 1/2"	75	82	107
902209	3"	83	96	123

Su richiesta /  
On request



Filettatura NPT / NPT thread

M7

Modello / Model

**GIUNTO 3 PEZZI MF / 3 PIECES UNION MF**

Materiale / Material

Aisi 316

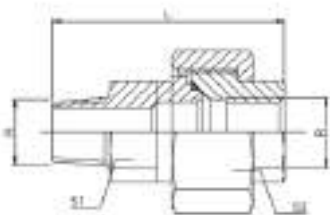

### Caratteristiche tecniche / Construction features

- **Giunto 3 pezzi MF con guarnizione in PTFE** / 3 pieces union MF with PTFE flat seat
- **Raccorderia filettata microfusa** / Microcasted threaded fittings
- **Connessioni filettate secondo** / Threaded ends according to ISO 10226-1
- **Temperatura di funzionamento** / Working temperature -20°C – +180°C
- **Pressione massima** / Max. working pressure 20 bar fino a / up to 40°C
- **Tolleranze** / Tolerances ISO 4144

Su richiesta /  
On request

Filettatura NPT / NPT thread

### Dimensioni e pesi / Dimensions and weights

Codice Code	Misura R Size R	Dimensioni in mm Dimensions in mm		
		L	S1	S2
902180	1/4"	44	17	29
902181	3/8"	47,5	20	34
902182	1/2"	54	25	39
902183	3/4"	58	30	47
902184	1"	68	38	58
902185	1" 1/4	74,5	47	67
902186	1" 1/2	78,5	53	76
902187	2"	90	66	90
902188	2" 1/2	102	82	107
902189	3"	113	96	123

M7

Modello / Model

**MANICOTTO RIDOTTO FF / FF REDUCED SOCKET**

Materiale / Material

Aisi 316

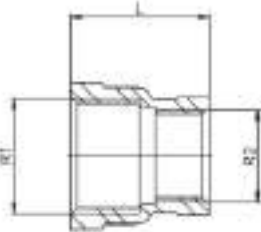

### Caratteristiche tecniche / Construction features

- **Raccorderia filettata microfusa** / Microcasted threaded fittings
- **Connessioni filettate secondo** / Threaded ends according to ISO 10226-1
- **Temperatura di funzionamento** / Working temperature -20°C – +180°C
- **Pressione massima** / Max. working pressure 20 bar fino a / up to 40°C
- **Tolleranze** / Tolerances ISO 4144

Su richiesta /  
On request

Filettatura NPT / NPT thread

### Dimensioni e pesi / Dimensions and weights

Codice Code	Misura R Size R	Dimensioni in mm Dimensions in mm
		L
902300	3/8" - 1/4"	26
902301	1/2" - 3/8"	34
902302	3/4" - 1/2"	36
902303	1" - 3/4"	42
902304	1" 1/4 - 1"	48
902305	1" 1/2 - 1" 1/4	52
902306	2" - 1" 1/2	58

M7

Modello / Model

**MANICOTTO / SOCKET**

Materiale / Material

Aisi 316



### Caratteristiche tecniche / Construction features

- **Raccorderia filettata microfusa** / Microcasted threaded fittings
- **Connessioni filettate secondo** / Threaded ends according to ISO 10226-1
- **Temperatura di funzionamento** / Working temperature -20°C – +180°C
- **Pressione massima** / Max. working pressure 20 bar fino a / up to 40°C
- **Tolleranze** / Tolerances ISO 4144

Su richiesta /  
On request

Filettatura NPT / NPT thread

### Dimensioni e pesi / Dimensions and weights

Codice Code	Misura R Size R	Dimensioni in mm Dimensions in mm	
		E	L
902401	1/4"	16,5	24
902403	3/8"	20	25
902405	1/2"	24,5	32
902407	3/4"	30	35
902409	1"	37,5	41
902411	1" 1/4	46,5	45
902413	1" 1/2	53	45
902415	2"	65,5	54
902416	2" 1/2	82	63
902417	3"	95,5	69

M7

Modello / Model

**TRONCHETTO / WELDING NIPPLE**

Materiale / Material

Aisi 316

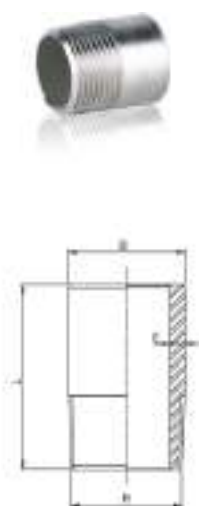

### Caratteristiche tecniche / Construction features

- **Raccorderia filettata** / Threaded fittings
- **Connessioni filettate secondo** / Threaded ends according to ISO 10226-1
- **Temperatura di funzionamento** / Working temperature -20°C – +180°C
- **Pressione massima** / Max. working pressure 20 bar fino a / up to 40°C
- **Tolleranze** / Tolerances ISO 4144

Su richiesta /  
On request

Filettatura NPT / NPT thread

### Dimensioni e pesi / Dimensions and weights

Codice Code	Misura R Size R	Dimensioni in mm Dimensions in mm		
		B	E (min.)	L
903101	1/4"	13,7	2	30
903103	3/8"	17,1	2	30
903105	1/2"	21,3	2,5	35
903107	3/4"	26,7	2,5	40
903109	1"	33,7	3	40
903111	1" 1/4	42,2	3	50
903113	1" 1/2	48,3	3	50
903115	2"	60,3	3	50
903117	2" 1/2	76,1	4	60
903119	3"	88,9	4	70
903123	4"	114,3	4	80

M7

Modello / Model

TAPPO MASCHIO / HEXAGONAL PLUG

Materiale / Material

Aisi 316

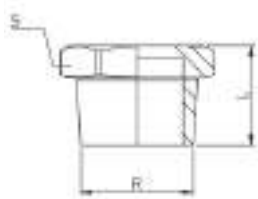

### Caratteristiche tecniche / Construction features

- **Raccorderia filettata microfusa** / Microcasted threaded fittings
- **Connessioni filettate secondo** / Threaded ends according to ISO 10226-1
- **Temperatura di funzionamento** / Working temperature -20°C – +180°C
- **Pressione massima** / Max. working pressure 20 bar fino a / up to 40°C
- **Tolleranze** / Tolerances ISO 4144

Su richiesta /  
On request

Filettatura NPT / NPT thread

### Dimensioni e pesi / Dimensions and weights

Codice Code	Misura R Size R	Dimensioni in mm Dimensions in mm	
		L	S
902600	1/4"	14,5	15
902601	3/8"	16	18
902602	1/2"	19,5	23
902603	3/4"	21	28
902604	1"	24	35
902605	1" 1/4	27	44
902606	1" 1/2	27	50
902607	2"	32	62
902608	2" 1/2	34	77
902609	3"	37,5	90

M7

Modello / Model

CALOTTA FEMMINA / HEXAGONAL CAP

Materiale / Material

Aisi 316

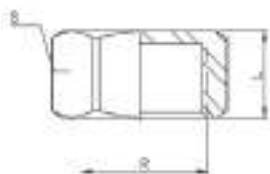

### Caratteristiche tecniche / Construction features

- **Raccorderia filettata microfusa** / Microcasted threaded fittings
- **Connessioni filettate secondo** / Threaded ends according to ISO 10226-1
- **Temperatura di funzionamento** / Working temperature -20°C – +180°C
- **Pressione massima** / Max. working pressure 20 bar fino a / up to 40°C
- **Tolleranze** / Tolerances ISO 4144

Su richiesta /  
On request

Filettatura NPT / NPT thread

### Dimensioni e pesi / Dimensions and weights

Codice Code	Misura R Size R	Dimensioni in mm Dimensions in mm	
		L	S
902700	1/4"	14	18
902701	3/8"	14,5	20
902702	1/2"	18,5	25
902703	3/4"	19,5	30
902704	1"	22,5	38
902705	1"1/4	25,5	47
902706	1"1/2	25,5	53
902707	2"	30	66
902708	2"1/2	35	82
902709	3"	38,5	96
902710	4"	45	122

M7

Modello / Model

**CONTRODADO / HEXAGONAL NUT**

Materiale / Material

Aisi 316

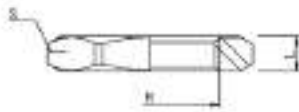
**Caratteristiche tecniche /**

Construction features

- **Raccorderia filettata microfusa** / Microcasted threaded fittings
- **Connessioni filettate secondo** / Threaded ends according to ISO 10226-1
- **Temperatura di funzionamento** / Working temperature  
-20°C – +180°C
- **Pressione massima** / Max. working pressure  
20 bar fino a / up to 40°C
- **Tolleranze** / Tolerances  
ISO 4144

**Dimensioni e pesi /**

Dimensions and weights

Codice Code	Misura R Size R	Dimensioni in mm Dimensions in mm	
		L	S
902800	1/4"	7	18
902801	3/8"	7	24
902802	1/2"	8	30
902803	3/4"	9	34
902804	1"	9	43
902805	1" 1/4	11	52
902806	1" 1/2	12	58
902807	2"	13	72

M7

Modello / Model

**BARILOTTO / EXTENSION SCREW**

Materiale / Material

Aisi 316

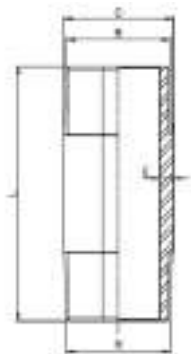
**Caratteristiche tecniche /**

Construction features

- **Raccorderia filettata** / Threaded fittings
- **Connessioni filettate secondo** / Threaded ends according to ISO 10226-1
- **Temperatura di funzionamento** / Working temperature  
-20°C – +180°C
- **Pressione massima** / Max. working pressure  
20 bar fino a / up to 40°C
- **Tolleranze** / Tolerances  
ISO 4144

**Dimensioni e pesi /**

Dimensions and weights

Codice Code	Misura R Size R	Dimensioni in mm Dimensions in mm		
		B	E (min.)	L
902901	1/4"	13,7	2	40
902903	3/8"	17,1	2	40
902905	1/2"	21,3	2,5	60
902907	3/4"	26,7	2,5	60
902909/60	1"	33,7	3	60
902911	1" 1/4	42,2	3	80
902913	1" 1/2	48,3	3	80
902915	2"	60,3	3	100
902917	2" 1/2	76,1	4	100
902919	3"	88,9	4	120
902921	4"	114,3	4	150

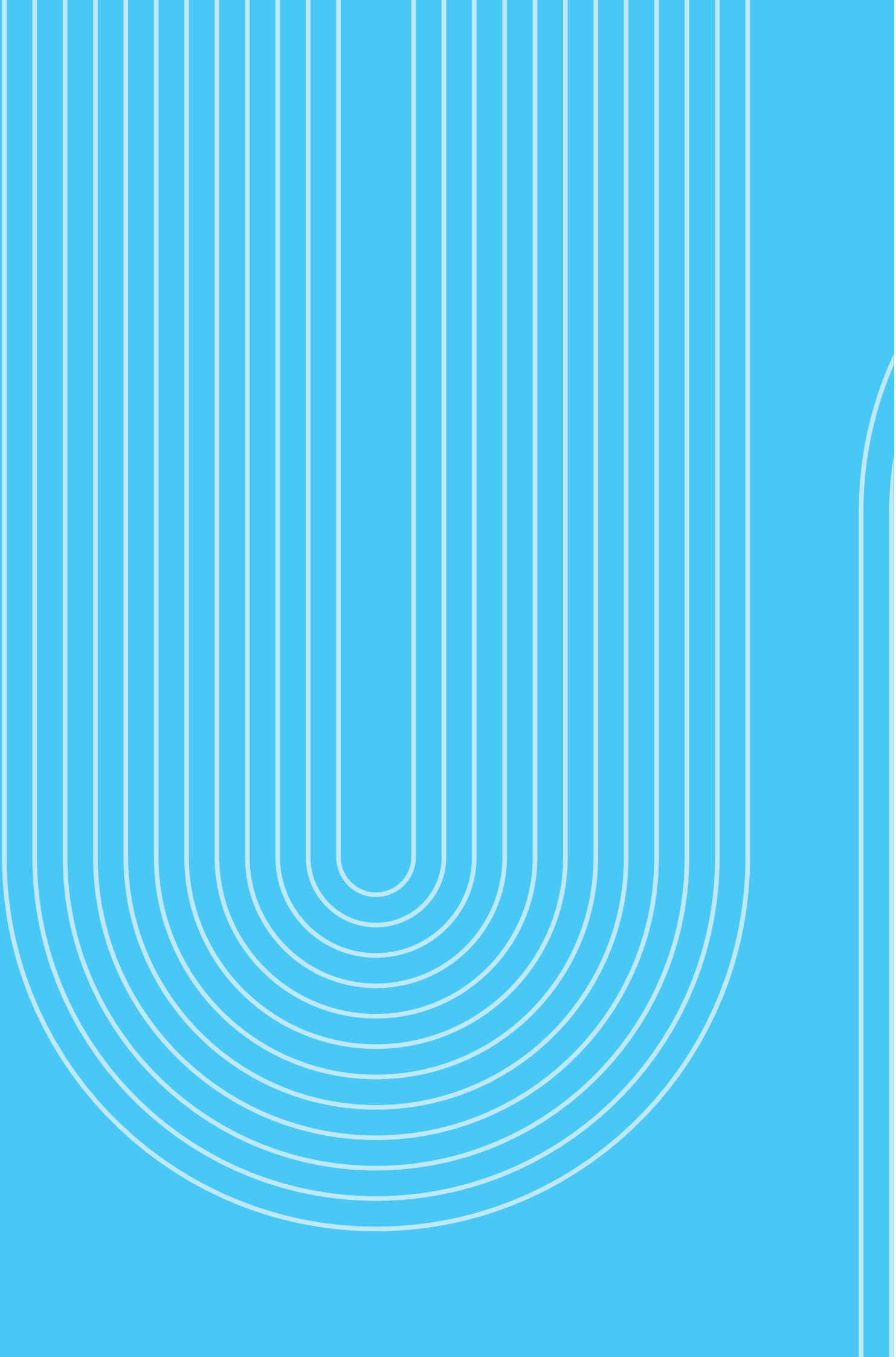

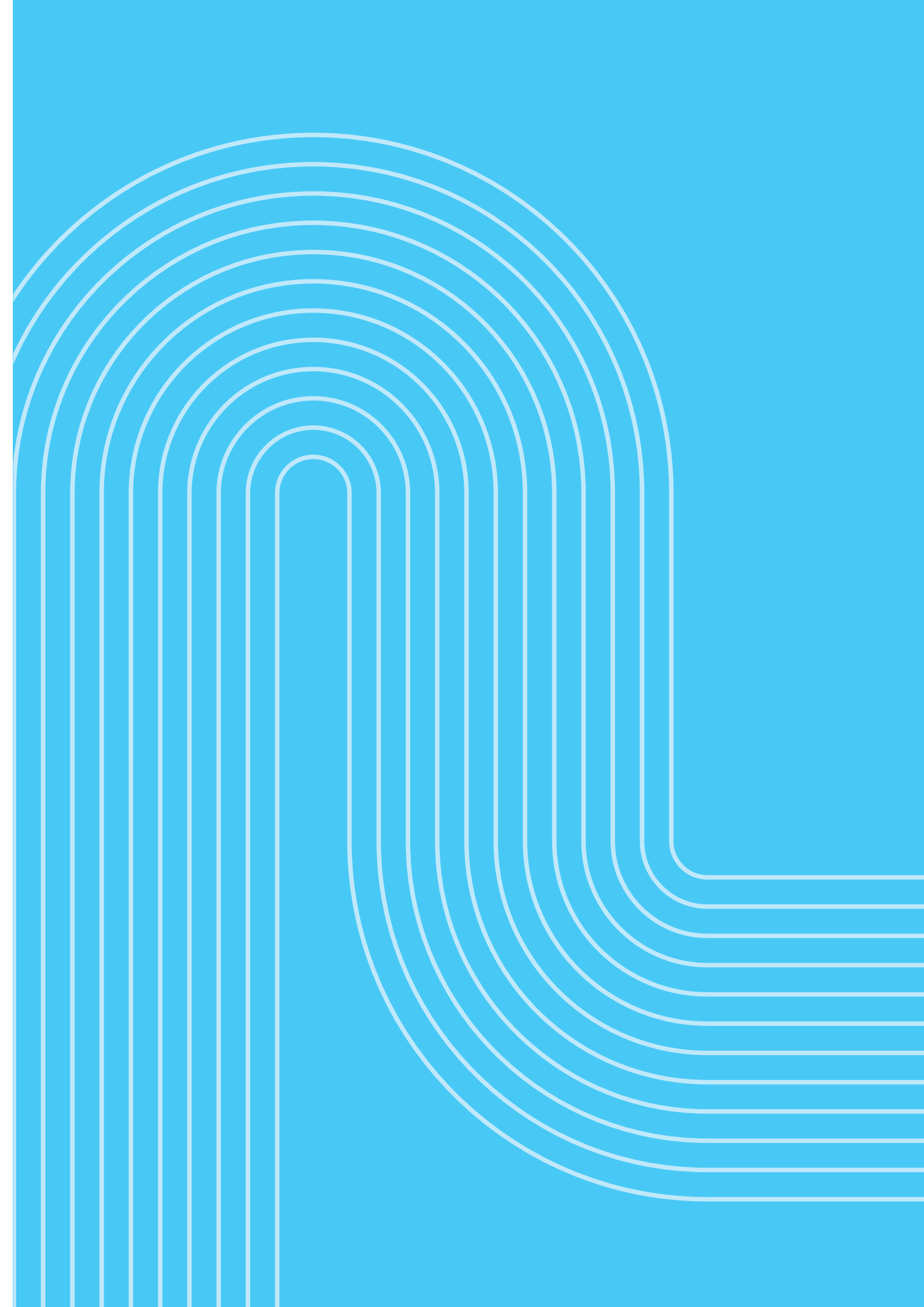



## MONDEO SRL

Strada del Capitello s/n  
36075 Montecchio Maggiore (VI) - Italy  
P. IVA IT 01813340245

Tel +39 0444695811  
Fax +39 0444490376

PEC: mondeosrl@legalmail.it  
info@mondeovalves.it  
www.mondeovalves.it

 Mondeo Valves

